

2014 GMC 1500 FBR Part # 300-31-4008, XFBR Part # 600-31-4009 - WILL FIT ALL 1500 MODELS INCLUDING FRONT PARK ASSIST!!

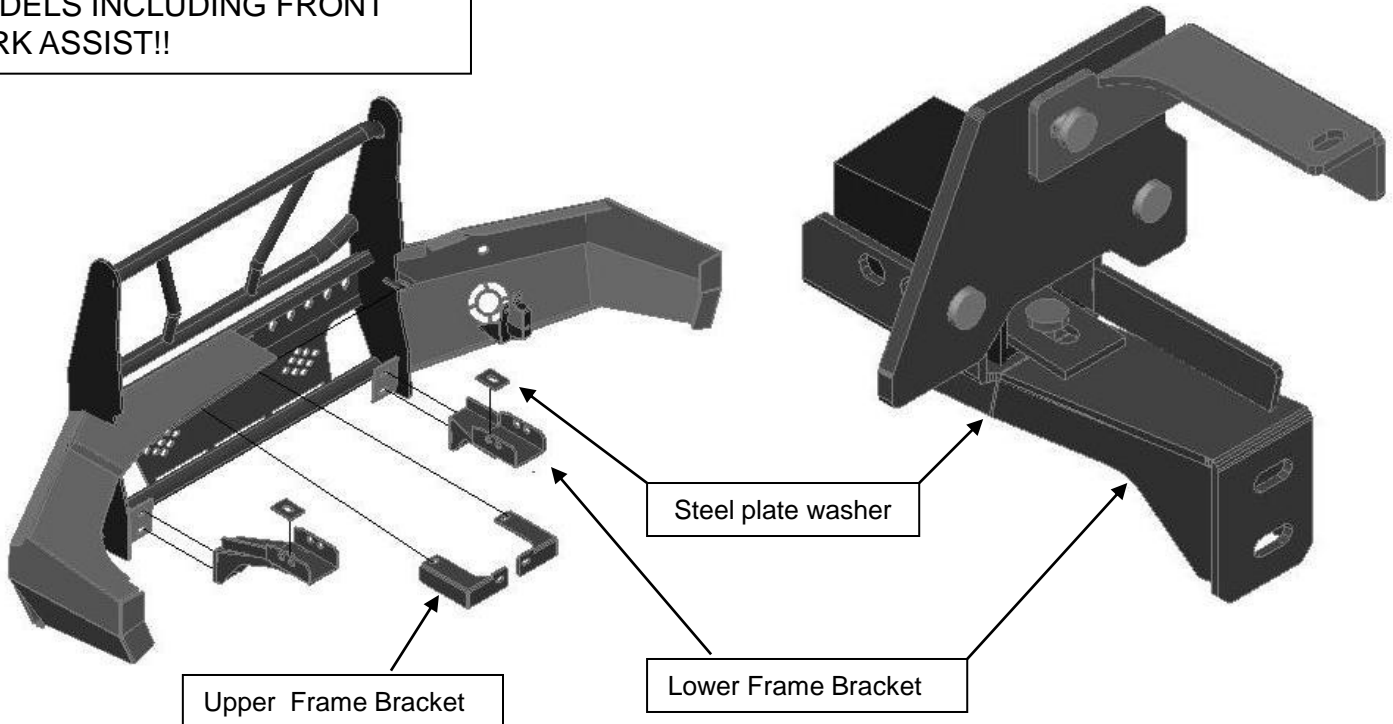

**Step 1:** Remove plastic trim on top of chrome bumper. This is done by removing a series of small bolts/screws on the ends by the fender wells. The center is held in place by plastic pegs that you can get to from underneath the vehicle.

**Step 2:** Remove factory chrome bumper. **TOW HOOK MODELS:** You will need to remove tow hooks in order to mount frontier Lower frame bracket. Remount tow hook at same time you bolt up the lower frame Brackets. **NON-TOW HOOK MODELS:** Use 1/2" X 1 3/4" bolts supplied to mount Frontier lower frame brackets. In order to secure bracket as tight as possible you must install our 1/2" bolt through the pre-punched hole on top of the bracket and squeeze bracket tightly to the tip of frame using the steel plate provided as a washer.

**Step 3:** Place upper plastic bumper pad back in place

**Step 4:** Install factory fog lights to front end using the 3/8" washers to hold light to steel bracket. Install Frontier FBR to lower frame brackets. Align + tighten all 4 bolts.

**Step 5:** Install Upper frame brackets to top of frame cap using the factory bolt.

**Step 6:** Check alignment of FBR to truck before tightening bolts on the upper brackets.

**Bolt Bag Contents:**

Qty	Description
28	1/2" Flat Washers
14	1/2" Lock Washers
14	1/2" Hex Nuts
14	1/2" X 1 3/4" Bolts
2	Lower Frame Brkts
2	Upper Frame Brkts
6	3/8" flat washers
2	1/4" X 1" Bolts
2	1/4" Lock Washers
2	1/4" Hex Nuts
4	1/4" flat washers
2	Steel plate washers
4	Grommets/plugs
96	Total Pieces