

Bolt Bag Contents:

Quantity	Description
2	Bottom support brackets
20	1/2" Flat Washers
10	1/2" X 1-3/4" Bolts
10	1/2" Hex Nuts
10	1/2" Lock Washers
10	1/4" Lock washers
20	1/4" flat washers
10	1/4" Lock nut
10	1/4" X 1" hex bolts
102	Total Pieces

**2008-2010 Ford F250-F450 FBR
Installation Instructions.
Part # 300-10-8005, XFBR 600-10-8005**

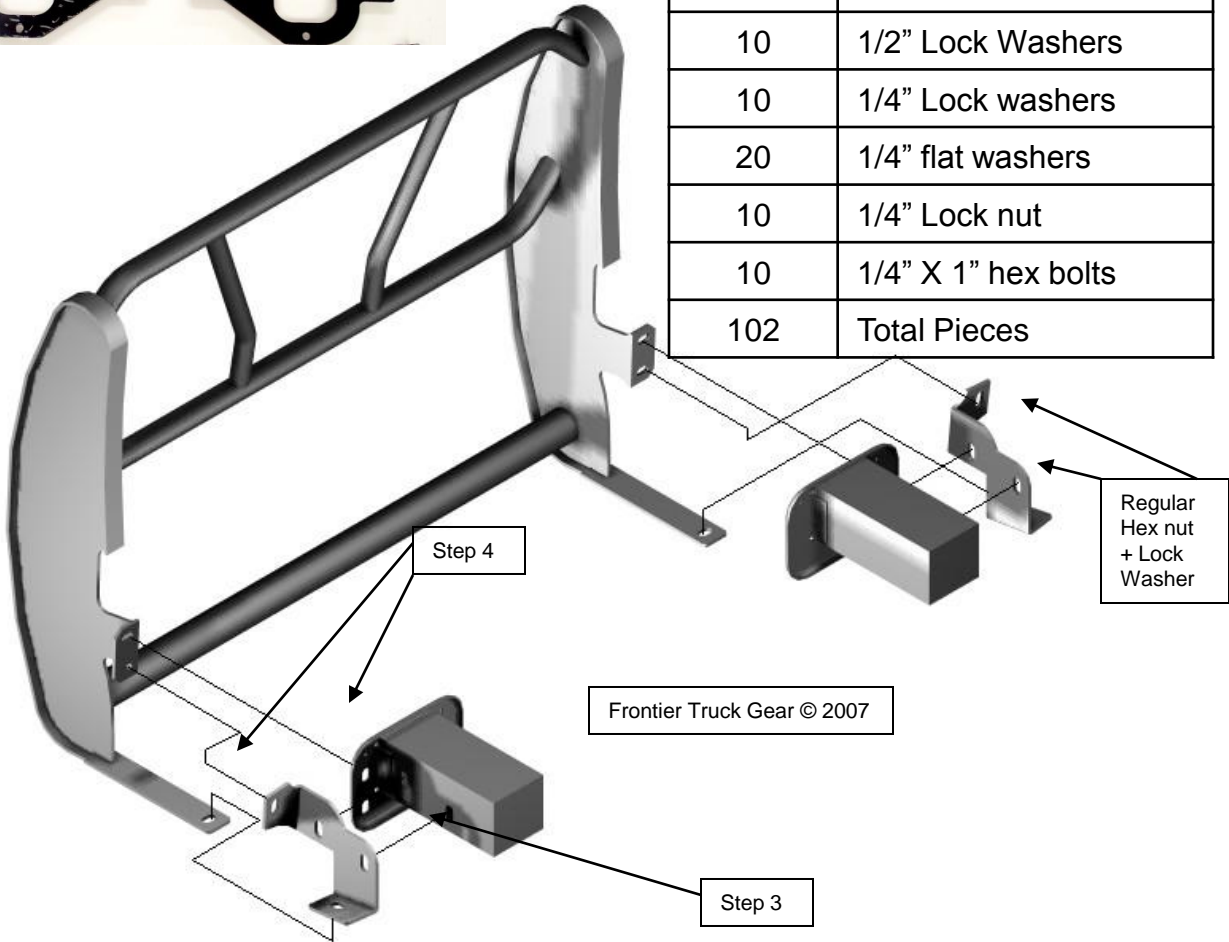
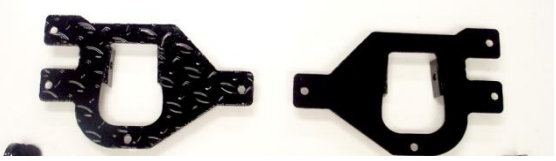

- Step 1:** [Remove factory bumper](#). Note: Do not remove factory tow hooks. Important: Remove hood latch and bracket and re-attach to pegs welded to the underside of diamond plate deck of FBR.
- Step 2:** Remove factory fog lights from factory bumper and attach to bracket provided. Attach this bracket and light to the pegs on the underside of FBR.
- Step 3:** Install bottom support bracket behind frame horn. NOTE: You must use regular 1/2" hex nuts and 1/2" lock washers on the bolts going through the truck frame!! You will access the bolt head through a small hole located on the inside/bottom of truck frame when you are tightening.
- Step 4:** Mount Front Bumper Replacement (FBR) to frame horn and Bottom Support Bracket using 1/2" lock nuts. Bolts will go through the FBR bracket and the frame horn on the front. Foot of FBR on the bottom goes UNDER bottom support bracket.
- Step 5:** Check alignment of FBR to truck and tighten all bolts.