

**2005-2007 Ford Super Duty F250-F450, Excursion Front Bumper
Replacement Part # 300-10-5005, XFBR 600-10-5005**

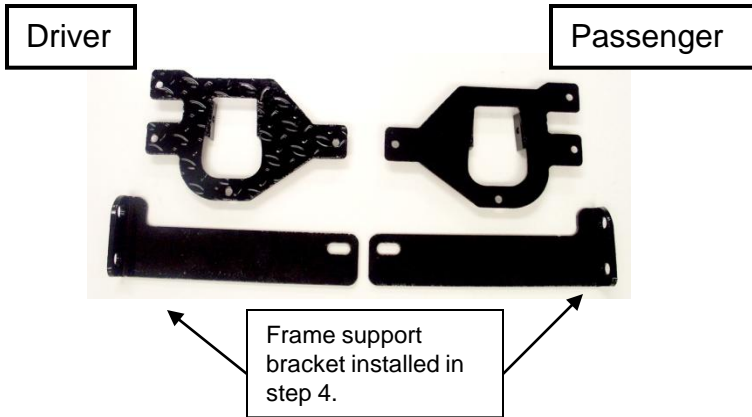

Bolt Bag Contents:	
Quantity	Description
12	1/2" Flat Washers
6	1/2" X 1-3/4" Bolts
6	1/2" Lock Washer
6	1/2" Hex Nuts
8	1/4" X 1" Bolts
8	1/4" Hex Nuts
16	1/4" Flat washers
8	1/4" Lock washers
2	Frame support brackets
72	Total Pieces

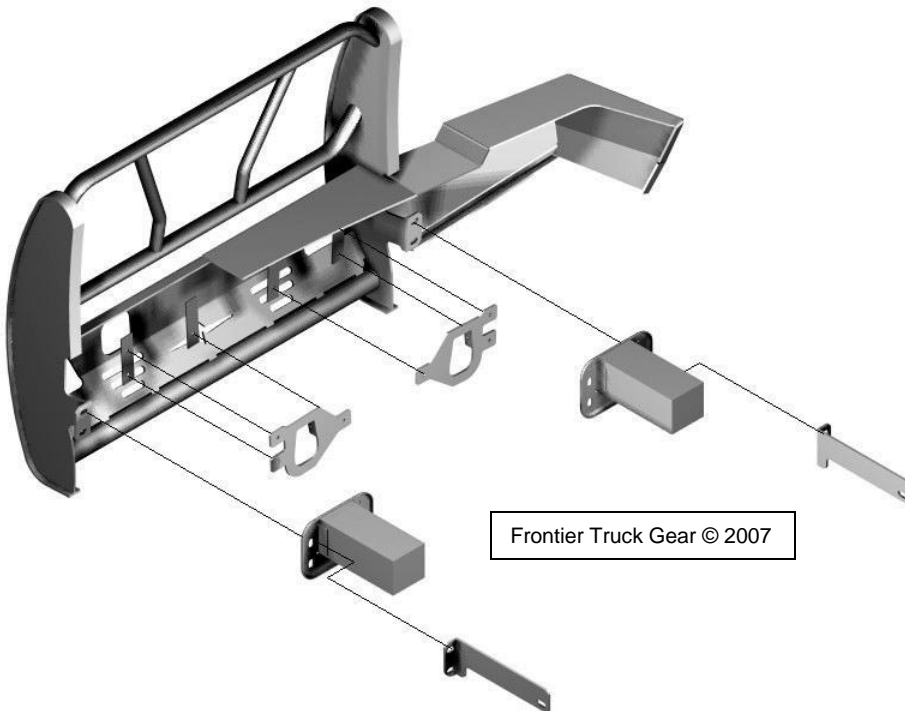

Step 3

Step 1: Remove factory bumper. Note: **Do not remove factory tow hooks.**

Step 2: Remove ford fog light from plastic housing and install in metal fog light brackets. Use plastic tabs from Ford housing for side holes and use the Ford adjusting bolt for top hole. Ensure the light is turned so that the beam fans flat and not up and down. (Note: the driver side light from the ford bumper will be the driver side light in the front bumper replacement).

Step 3: Install frame support bracket behind frame horn

Step 4: Mount front end replacement to frame horn using the outside bolt holes. 1/2" Bolts will go through the front end bracket, the frame horn, and the frame support bracket (that was installed in step 4).

Step 5: Check alignment of front end replacement to truck and tighten all bolts.