

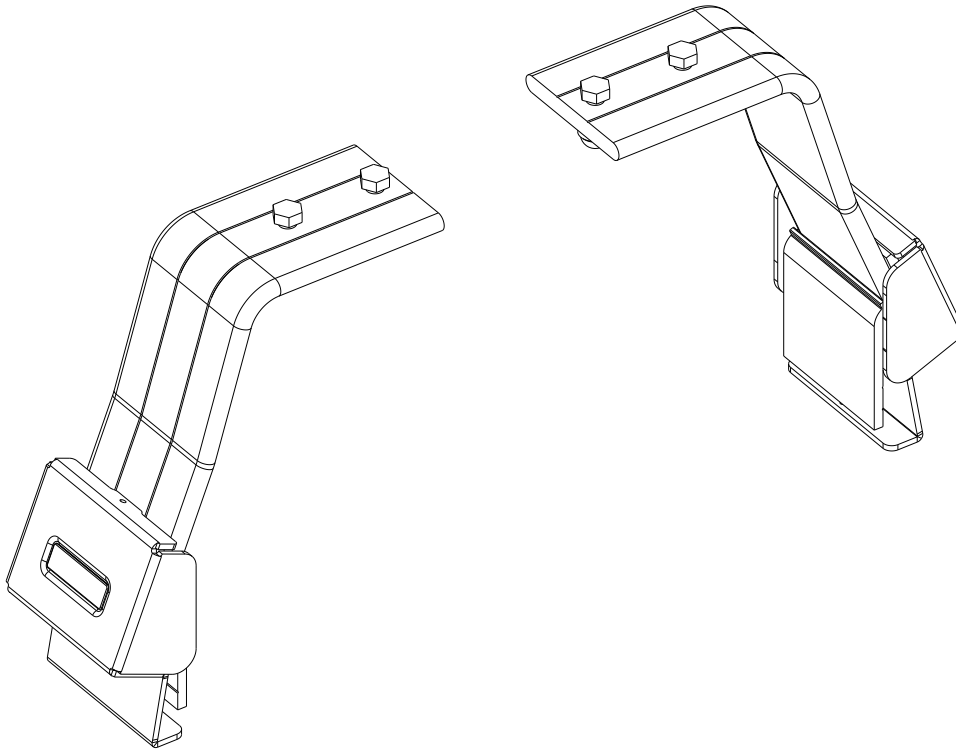

FRONT RUNNER
VEHICLE OUTFITTERS

LEG ASSEMBLY

LASSUNI



READ ME !

Thank you for purchasing a Front Runner Leg Assembly.

Before you start, take a moment to familiarize yourself with the Fitting Instructions and the components received.

Refer to Page 2 for a list of all the components, quantities and tools required.

IMPORTANT WARNING!

IT IS CRITICAL THAT ALL FRONT RUNNER PRODUCTS BE PROPERLY AND SECURELY ASSEMBLED AND ATTACHED TO YOUR VEHICLE. IMPROPER ATTACHMENT COULD RESULT IN AN AUTOMOBILE ACCIDENT, AND COULD CAUSE SERIOUS BODILY INJURY OR DEATH. YOU ARE RESPONSIBLE FOR ASSEMBLING AND SECURING ALL FRONT RUNNER PRODUCTS TO YOUR VEHICLE, CHECKING THE ATTACHMENTS PRIOR TO USE, AND PERIODICALLY INSPECTING THE PRODUCTS FOR ADJUSTMENT, WEAR AND DAMAGE. THEREFORE, YOU MUST READ AND UNDERSTAND ALL OF THE INSTRUCTIONS AND PRECAUTIONS SUPPLIED WITH YOUR FRONT RUNNER PRODUCT PRIOR TO INSTALLATION OR USE. IF YOU DO NOT UNDERSTAND ALL OF THE INSTRUCTIONS AND CAUTIONS, OR IF YOU HAVE NO MECHANICAL EXPERIENCE AND ARE NOT THOROUGHLY FAMILIAR WITH THE INSTALLATION PROCEDURES, YOU SHOULD HAVE THE PRODUCT INSTALLED BY A PROFESSIONAL INSTALLER OR OTHER QUALIFIED PERSONNEL.

NOTE: Front Runner will not be responsible for any damage caused by the failure to install the product according to these instructions.

1

GET ORGANIZED

IN THE BOX

1	2 X	Leg
2	4 X	M8 x 25 Hex Bolt
3	2 X	M8 x 16 x 1.6SS Flat Washer
4	4 X	M8 Nyloc Nut
5	4 X	M8 Nut Cap
6	2 X	Gutter Clamp
7	2 X	M8 SS Spring Washer
8	2 X	M8 x 30 Button Head Bolt
9	2 X	Diagonal Leg
10	2 X	Leg Base

TOOLS NEEDED



FIGURE 1.1 - LEG

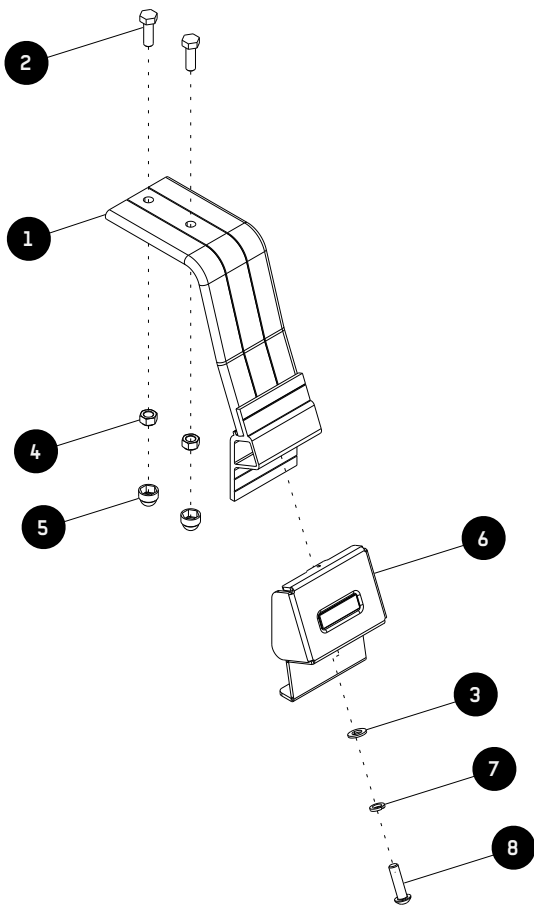
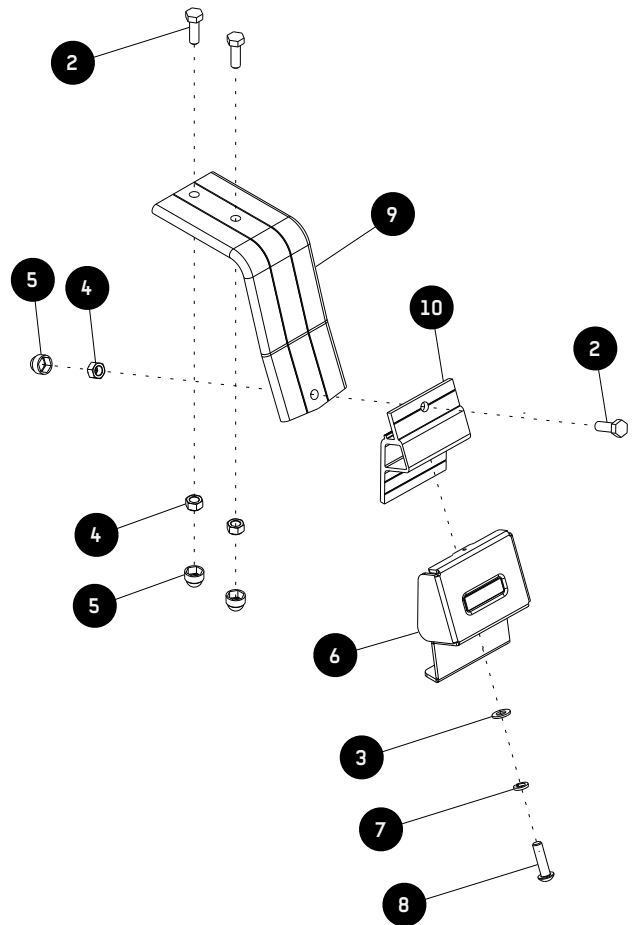
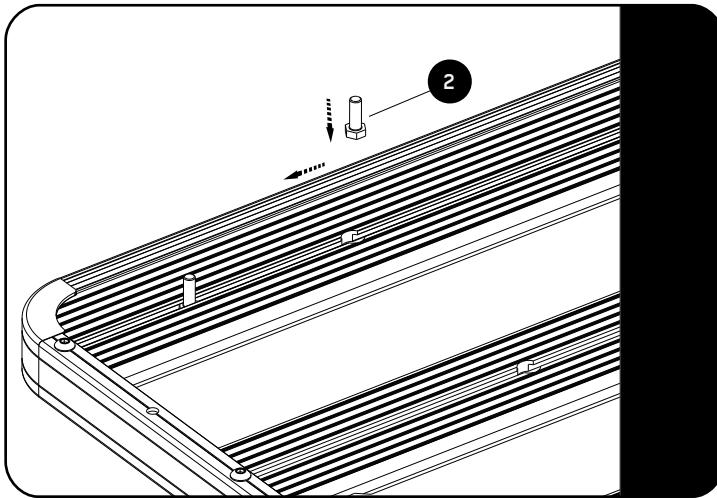

FIGURE 1.2 - DIAGONAL LEG



2**FIT AND SECURE**

2.1



RECOMMENDED SPACING BETWEEN LEGS OR FEET ARE 3 SLATS.

SPACING MAY NOT EXCEED 4 SLATS.



Slide two M8 x 25 Hex Bolts (Item 2) into the Slats machined slots.

2.2

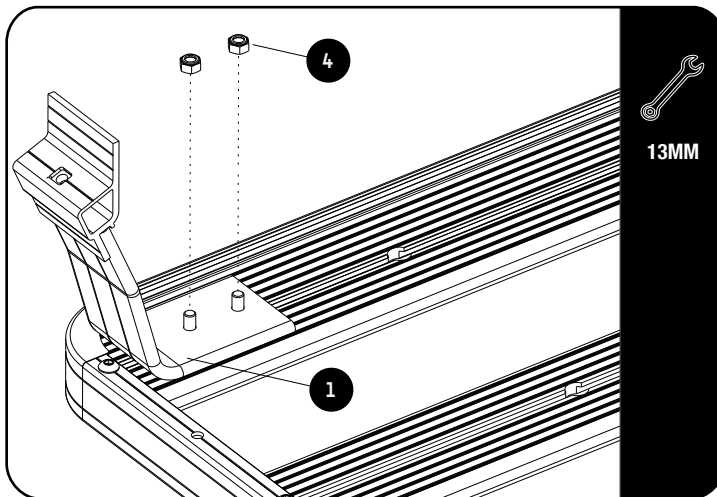

IF YOU ARE FITTING A DIAGONAL LEG, REFER TO FIGURE 1.2 FOR ASSEMBLY.



Loosly fit the Legs (Item 1 OR 9) using M8 Nyloc Nuts (items 3 & 4)

Flip the Rack over and position over the vehicle's roof. Let a friend help. Check that all the legs are seated in the gutter.

Check that the leg is correctly seated under the rack and adjust if needed. Fully tighten the leg to the rack and place Nut caps over all the nuts.



Tightening Torque 25Nm / 18.4 ft lbs

2.3

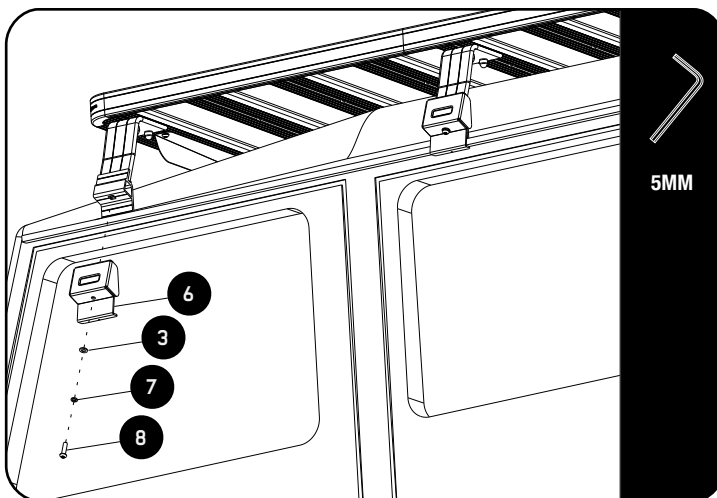

Secure the Gutter Clamps (Item 6) using M8 x 30 Button Heads, M8 Spring Washers and M8 x 16 x 1.6 Flat Washers (Items 3, 7 & 8). Check that the Clamp is seated correctly under the gutter before tightening.



Tightening Torque 16Nm / 11.8 ft lbs

3

FINISH

Congratulations! You did it. Take a step back and admire your work!

4

INSTALL OTHER VEHICLE AND RACK ACCESSORIES



1

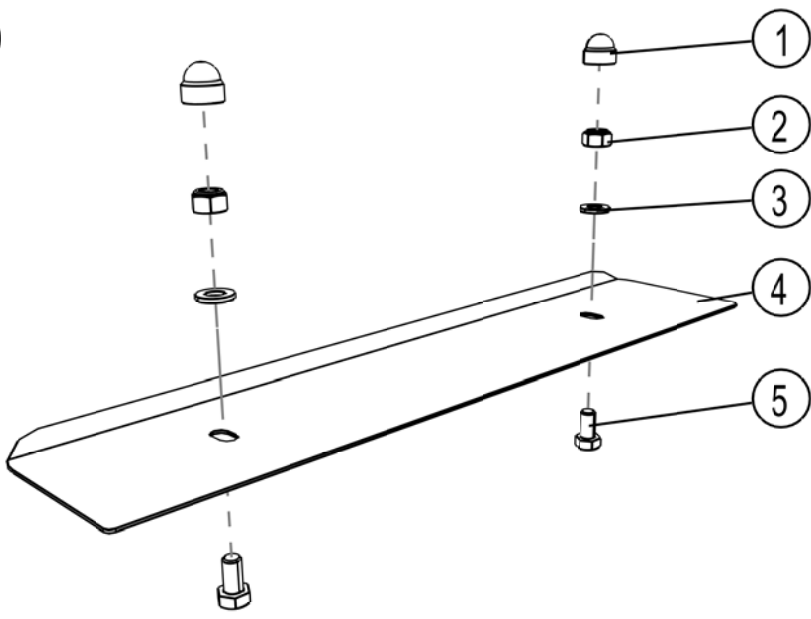

You will need:

- 13 mm Flat or Socket Wrench
- Measuring Tape

Item #	Quantity	Description
1	2	M8 NUT CAP
2	2	M8 NYLOC NUT
3	2	M8 FLAT WASHER
4	1	WIND DEFLECTOR
5	2	M8x16 HEX BOLT

2

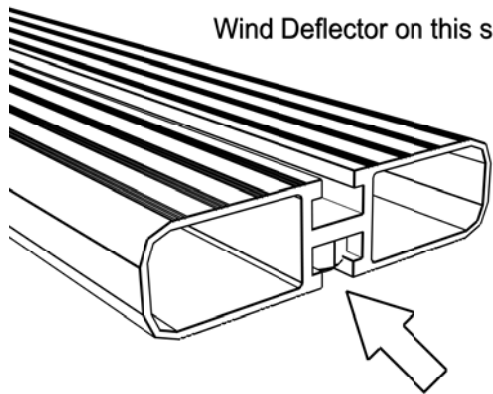

Wind Deflector on this side

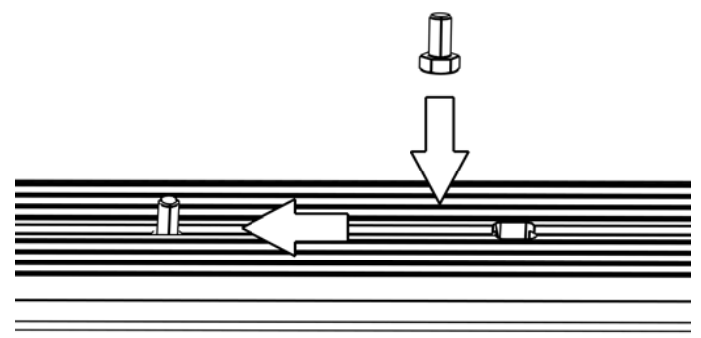

Ensure pre installed Nyloc Hex Nuts face downwards during Wind Deflector Fitment

