



FRONT RUNNER

**LAND ROVER DISCOVERY 3&4
SLIMLINE II RACK
(1255MM X 2166MM)**

ENG

FALD003 / KRLD028T



INSTALL TIME: 60 mins

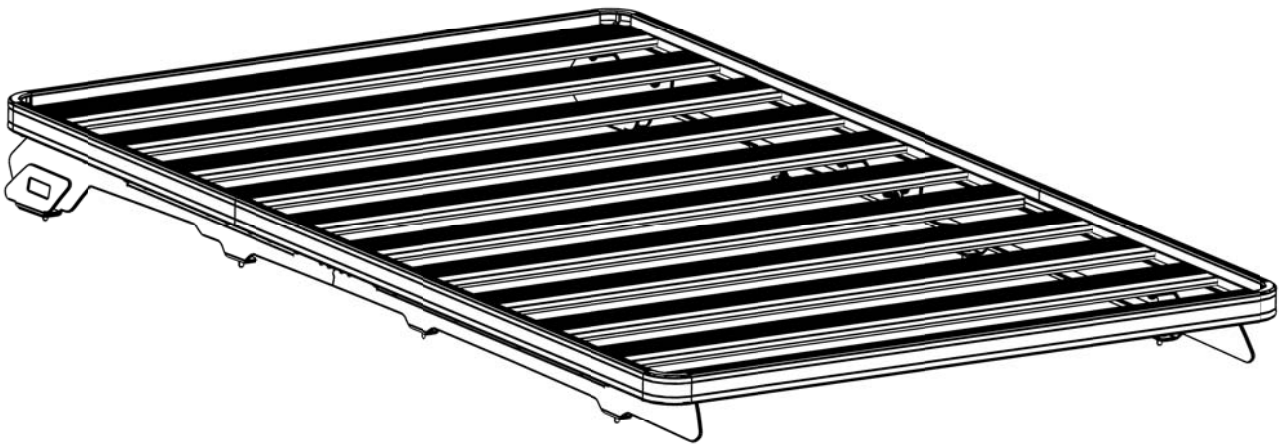

READ ME FIRST:

Thank you for purchasing a Front Runner Slimline II Rack.

This Roof Rack consists of a kit that contains:

- 1.) A Slimline II Tray
- 2.) A mounting system specific to your vehicle

This document will help you fit the Slimline II Tray to your specific vehicle.

IMPORTANT WARNING!

IT IS CRITICAL THAT ALL FRONT RUNNER PRODUCTS BE PROPERLY AND SECURELY ASSEMBLED AND ATTACHED TO YOUR VEHICLE. IMPROPER ATTACHMENT COULD RESULT IN AN AUTOMOBILE ACCIDENT, AND COULD CAUSE SERIOUS BODILY INJURY OR DEATH TO YOU OR TO OTHERS. YOU ARE RESPONSIBLE FOR ASSEMBLING AND SECURING ALL FRONT RUNNER PRODUCTS TO YOUR VEHICLE, CHECKING THE ATTACHMENTS PRIOR TO USE, AND PERIODICALLY INSPECTING THE PRODUCTS FOR ADJUSTMENT, WEAR, AND DAMAGE. THEREFORE, YOU MUST READ AND UNDERSTAND ALL OF THE INSTRUCTIONS AND CAUTIONS SUPPLIED WITH YOUR FRONT RUNNER PRODUCT PRIOR TO INSTALLATION OR USE. IF YOU DO NOT UNDERSTAND ALL OF THE INSTRUCTIONS AND CAUTIONS, OR IF YOU HAVE NO MECHANICAL EXPERIENCE AND ARE NOT THOROUGHLY FAMILIAR WITH THE INSTALLATION PROCEDURES, YOU SHOULD HAVE THE PRODUCT INSTALLED BY A PROFESSIONAL INSTALLER OR OTHER QUALIFIED PERSONNEL.

1

GET ORGANIZED...

Here is what you are looking at: Please note that only the right hand side's components have been shown.

Item #	Quantity	Description
1	16	M6 NUT CAP
2	8	M6 x 20 HEX BOLT
3	8	M6 SPRING WASHER
4	8	M6 x 19 FLAT WASHER
5	2	COVER PLATE - 1 LEFT, 1 RIGHT
6	12	M8 x 20 HEX BOLT
7	2	FRONT FOOTRAIL - 1 LEFT, 1 RIGHT
8	12	M8 FLAT WASHER
9	12	M8 NYLOC NUT
10	12	M8 NUT CAP
11	8	M6 NYLOC NUT
12	8	M6 FLAT WASHER
13	2	JOINER PLATE
14	8	M6 x 16 BUTTON HEAD BOLT
15	2	REAR FOOT RAIL - 1 LEFT, 1 RIGHT

You will need:

- 13 mm Flat and Socket Wrench
- 10 mm Flat and Socket Wrench
- 4 mm Hex Key
- Ladder
- Friend
- Measuring Tape
- Small Flat Screw Driver
- T27 Torx Bit

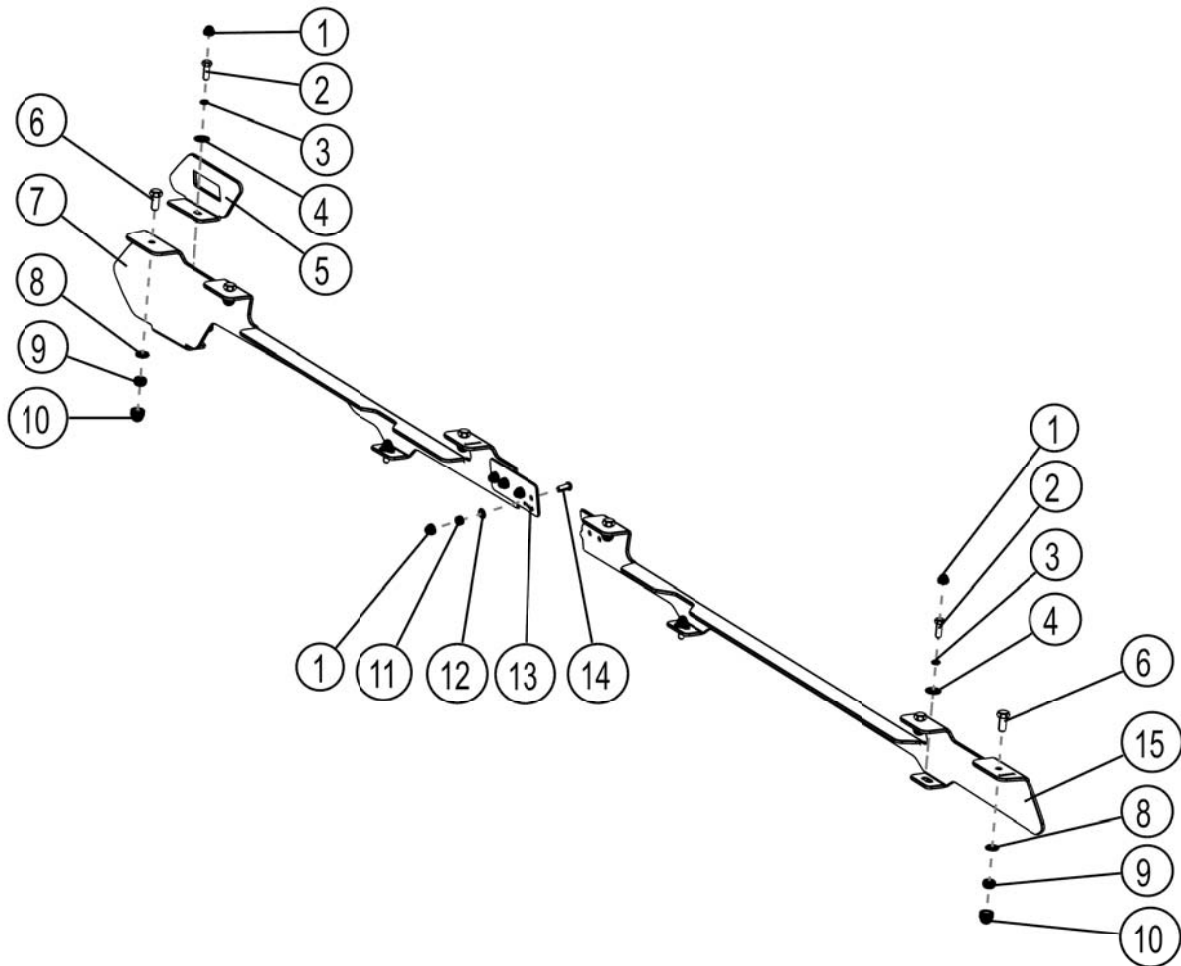

(A) Familiarize yourself with the parts and then step away from the work area and read through these instructions from beginning to end. Take a moment as a little prep now may save you a lot of time later.

2 FIT THE FOOT RAILS

- (A) Using your Torx Wrench, loosen and remove the two original tracks if fitted. If your vehicle did not come with these tracks, refer to Step 2D.



- (B) Use a small flat screwdriver and remove the plastic cap in the front ditch molding on either side of the sun roof to expose the threaded mounting points.

If your ditch moldings do not have the plastic caps, you will need to remove and drill holes in the ditch moldings. The position of the mounting points are best marked onto the ditch mouldings by screwing a sharpened M6 bolt with its head cut off into the mounting point, sharp side up. Place the ditch molding back on the vehicle and push on the area above the sharpened bolt, thereby marking the ditch moldings.



- (C) Loosely join the Front and Rear Foot Rails together using the M6 x 16 Button Head Bolts, M6 Flat Washers, M6 Nyloc Nuts and Joiner Plates (Items 7, 8, 9, 10).



2 FIT THE FOOT RAILS CONT...



Only complete Step 2D if your vehicle did not come fitted with the original tracks referred to in Step 2A.

- (D) Place the assembled Foot Rails onto the vehicle lining up the front mounting holes in the Foot Rail with the front mounting holes in the roof of the vehicle from Step 2B. Loosely fasten the front mounting foot of the Foot Rail to the vehicle using the M6 x 20 Hex Bolts, M6 x 19 Flat Washers and M6 Spring Washers (Items 2, 3, 4) supplied.

Mark the position (front and rear) of the three mounting feet onto the ditch moulding. Remove the foot rail and ditch moulding. Cut the ditch moulding 5 mm in from each of your markings and discard the pieces where the mounting feet sat. Reposition the ditch moulding pieces in their original position, leaving gaps where the Foot Rails mounting feet are positioned. Continue to Step 2E.

- (E) Place the assembled Foot Rails onto the vehicle lining up the mounting holes in the Foot Rails with the mounting holes in the roof. Starting from the front, place the Cover Plate (Item 5) on top of the Foot Rails as shown and loosely fasten the Foot Rails to the vehicle using the M6 x 20 Hex Bolts, M6 x 19 Flat Washers and M6 Spring Washers (Items 2, 3, 4). Line up the joint from Step 2C and fasten. Push the Foot Rails towards the rear of the vehicle and tighten all bolts securing the Foot Rails to the vehicle. Place a M6 Nut Cap over each of the Hex Bolts securing the Foot Rails to the vehicle and the Nyloc Nuts used to fasten the Joiner plates.

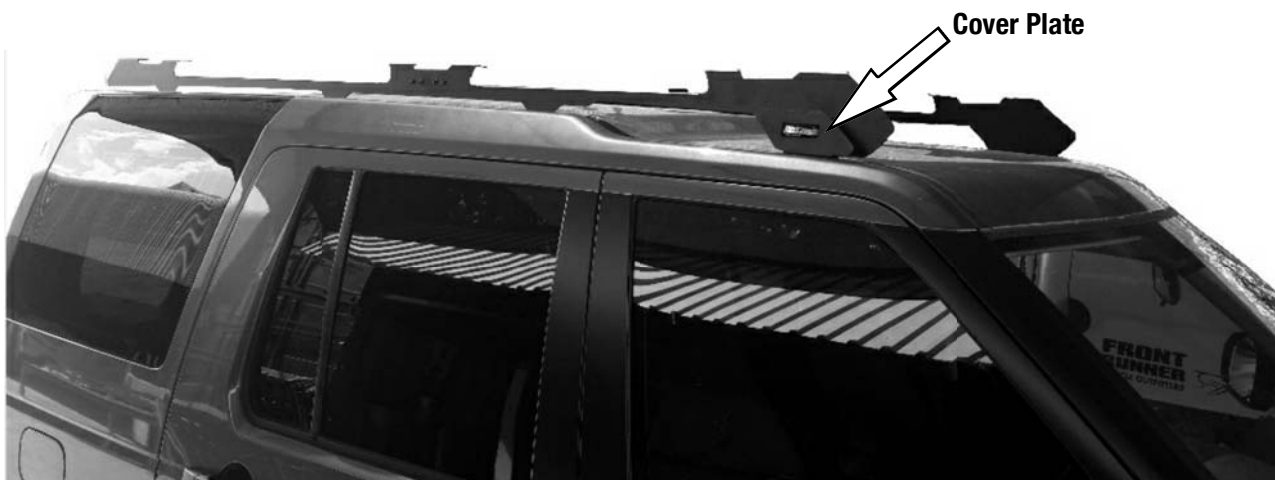

3 FIT THE RACK



Note: If your Slimline II Tray is not already assembled, assemble it as per the Slimline II Tray Universal Assembly Instruction (Document RRSUNI). Read Step 3A before fitting the Wind Deflector

- (A) Before fitting the Wind Deflector, and with the Rack in the upside down position, (Check with product sticker. It should be upside down), slide a M8 x 20 Hex Bolt (Item 6) into each end of the First Slat using the machined slot as shown.

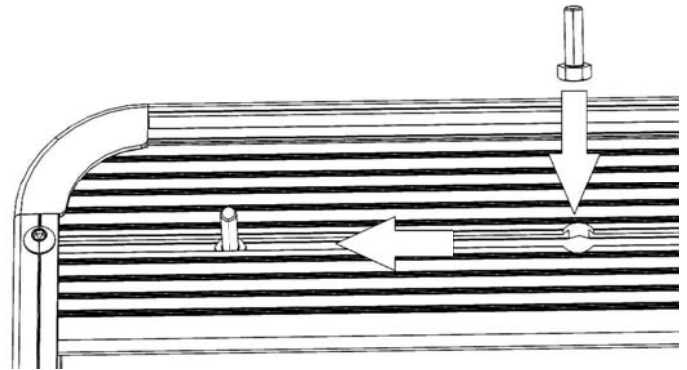

- (B) With your rack still upside down from Step 3A, slide a M8 x 20 Hex Bolt (Item 6) into each end of Slats 2, 5, 6, 10, 11.

Grab your Friend and with one of you on each side of the Rack, flip the Rack end over end (Prevents the Hex Bolts from falling out the machines slots) so that the M8 x 20 Hex Bolts are facing down. Approach the vehicle from the rear, with the Wind Deflector facing forward. Lift the Rack up and over the Roof positioning it above the Foot Rail. Bring the Rack down slowly, lining up the Bolts in the Rack with the holes in the top of the Foot Rail. Hand tighten the Rack to the Foot Rail using the M8 Washers and M8 Nyloc Nuts (Items 8 &9) supplied.

Center the rack - left to right (check using a tape measure). Fasten all the Nyloc Nuts securing the Rack to the Foot Rail. Cover the M8 Nyloc Nuts with the M8 Nut Caps (Item 10) supplied.

Congratulations, you have completed your installation. Take a step back and admire your work. Good Job!



4 TAKE A TRIP

- (**A**) After your first adventure, check that all nuts, bolts, screws and fittings are tight. Re-tighten where needed. You'll find a small amount of settling has happened.

Go on many more adventures, periodically checking all nuts, bolts, screws and fittings.



Front Runner can not recommend a maximum load carrying capacity. Please refer to your vehicle manufacturer's recommendations.



FRONT RUNNER

**LAND ROVER DISCOVERY 3&4
LOAD BAR KIT**

ENG

FALD003 / KRLD016



INSTALL TIME: 60 mins

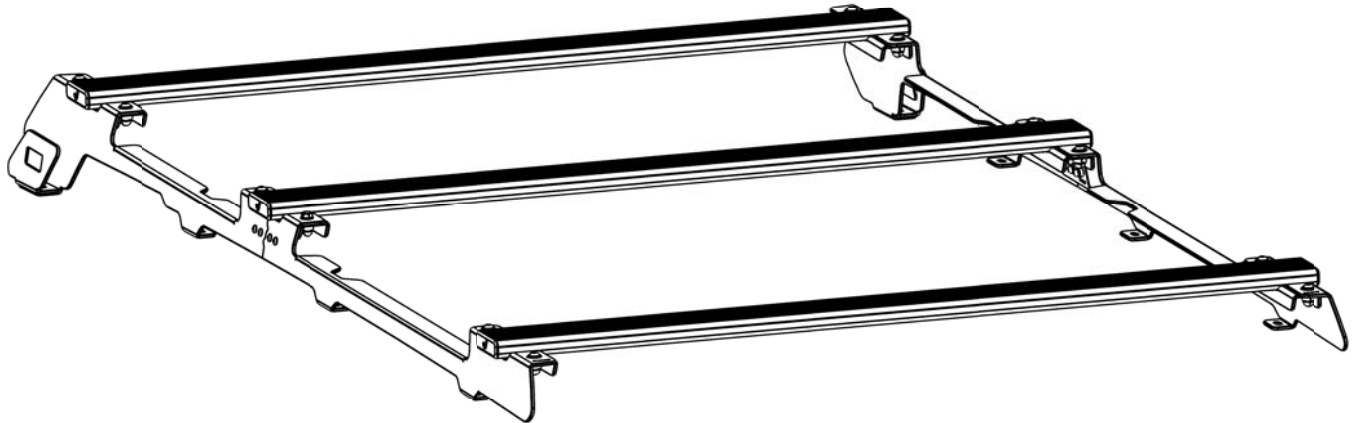

READ ME FIRST:



Thank you for purchasing a Front Runner Load Bar kit.

Your kit contains:

- 1.) A Load Bar Set
- 2.) A mounting system specific to your vehicle

This document will help you fit the Load Bars to your specific vehicle.

IMPORTANT WARNING!

IT IS CRITICAL THAT ALL FRONT RUNNER PRODUCTS BE PROPERLY AND SECURELY ASSEMBLED AND ATTACHED TO YOUR VEHICLE. IMPROPER ATTACHMENT COULD RESULT IN AN AUTOMOBILE ACCIDENT, AND COULD CAUSE SERIOUS BODILY INJURY OR DEATH TO YOU OR TO OTHERS. YOU ARE RESPONSIBLE FOR ASSEMBLING AND SECURING ALL FRONT RUNNER PRODUCTS TO YOUR VEHICLE, CHECKING THE ATTACHMENTS PRIOR TO USE, AND PERIODICALLY INSPECTING THE PRODUCTS FOR ADJUSTMENT, WEAR, AND DAMAGE. THEREFORE, YOU MUST READ AND UNDERSTAND ALL OF THE INSTRUCTIONS AND CAUTIONS SUPPLIED WITH YOUR FRONT RUNNER PRODUCT PRIOR TO INSTALLATION OR USE. IF YOU DO NOT UNDERSTAND ALL OF THE INSTRUCTIONS AND CAUTIONS, OR IF YOU HAVE NO MECHANICAL EXPERIENCE AND ARE NOT THOROUGHLY FAMILIAR WITH THE INSTALLATION PROCEDURES, YOU SHOULD HAVE THE PRODUCT INSTALLED BY A PROFESSIONAL INSTALLER OR OTHER QUALIFIED PERSONNEL.

1

GET ORGANIZED...

Here is what you are looking at: Please note that only the right hand side's components have been shown and that not all fasteners received will be used.

Item #	Quantity	Description
1	16	M6 NUT CAP
2	8	M6 x 20 HEX BOLT
3	8	M6 SPRING WASHER
4	8	M6 x 19 FLAT WASHER
5	1	COVER PLATE
6	2	FRONT FOOT RAIL - 1 LEFT, 1 RIGHT
7	8	M6 x 16 BUTTON HEAD BOLT
8	2	JOINER PLATE
9	8	M6 FLAT WASHER
10	8	M6 NYLOC NUT
11	2	REAR FOOT RAIL - 1 LEFT, 1 RIGHT

You will need:

- 13 mm Flat and Socket Wrench
- 10 mm Flat and Socket Wrench
- 4 mm Hex Key
- Ladder
- Friend
- Measuring Tape
- Small Flat Screw Driver
- T27 Torx Wrench

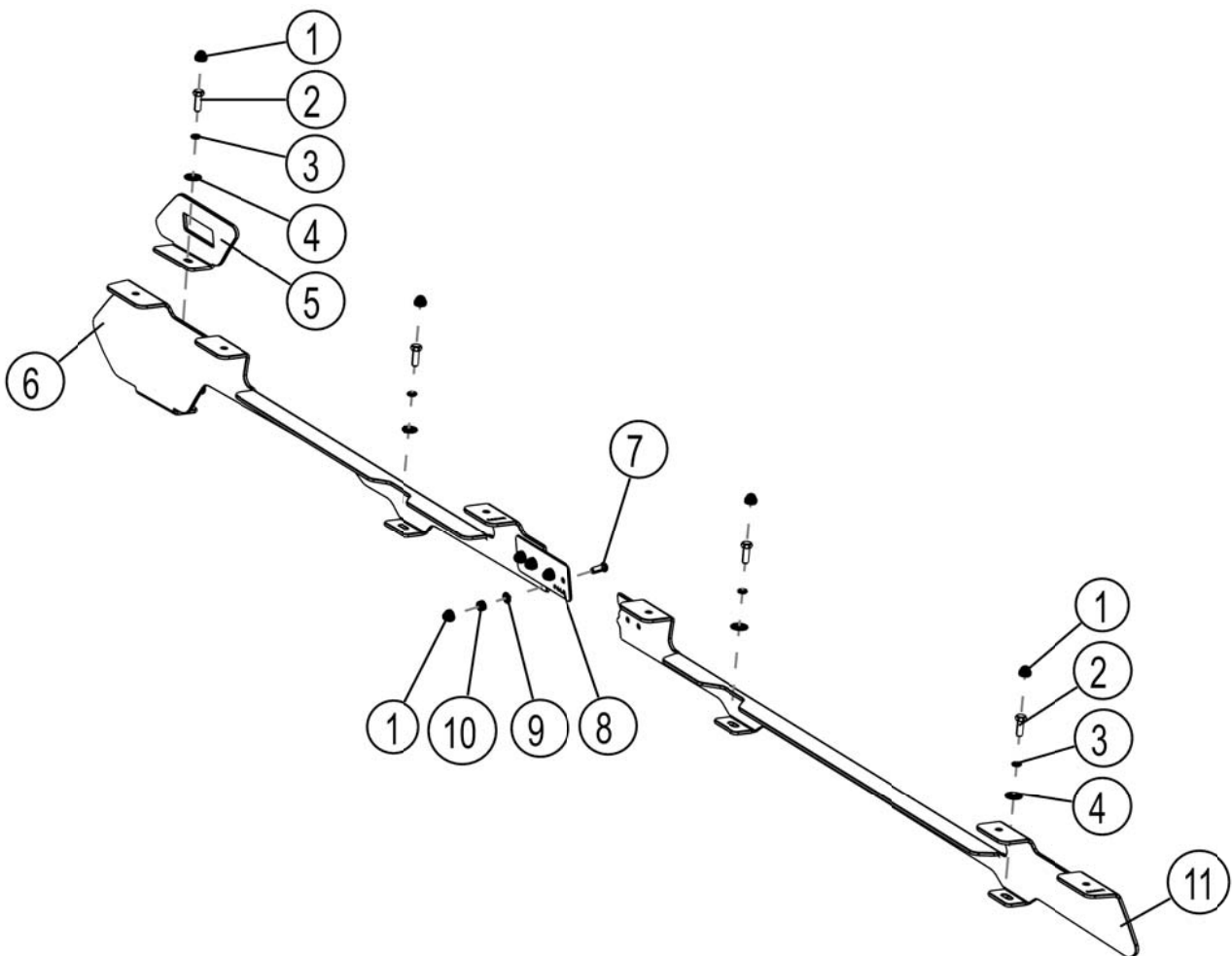

(A) Familiarize yourself with the parts and then step away from the work area and read through these instructions from beginning to end. Take a moment as a little prep now may save you a lot of time later.

2

FIT THE FOOT RAILS

- (A) Using your Torx Wrench, loosen and remove the two original tracks if fitted. If your vehicle did not come with these tracks, refer to Step 2D.



- (B) Use a small flat screwdriver and remove the plastic cap in the front ditch molding on either side of the sun roof to expose the threaded mounting points.

If your ditch moldings do not have the plastic caps, you will need to remove and drill holes in the ditch moldings. The position of the mounting points are best marked onto the ditch mouldings by screwing a sharpened M6 bolt with its head cut off into the mounting point, sharp side up. Place the ditch molding back on the vehicle and push on the area above the sharpened bolt, thereby marking the ditch moldings.



- (C) Loosely join the Front and Rear Foot Rails together using the M6 x16 Button Head Bolts, M6 Flat Washers, M6 Nyloc Nuts and Joiner Plates (Items 7, 8, 9, 10).

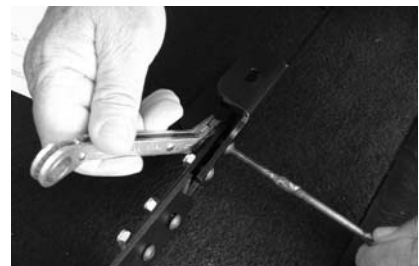

2 FIT THE FOOT RAILS CONT...



Only complete Step 2D if your vehicle did not come fitted with the original tracks referred to in Step 2A.

- (D) Place the assembled Foot Rails onto the vehicle lining up the front mounting holes in the Foot Rail with the front mounting holes in the roof of the vehicle from Step 2B. Loosely fasten the front mounting foot of the Foot Rail to the vehicle using the M6 x 20 Hex Bolts, M6 x 19 Flat Washers and M6 Spring Washers (Items 2, 3, 4) supplied.

Mark the position (front and rear) of the three mounting feet onto the ditch moulding. Remove the foot rail and ditch moulding. Cut the ditch moulding 5 mm in from each of your markings and discard the pieces where the mounting feet sat. Reposition the ditch moulding pieces in their original position, leaving gaps where the Foot Rails mounting feet are positioned. Continue to Step 2E.

- (E) Place the assembled Foot Rails onto the vehicle lining up the mounting holes in the Foot Rails with the mounting holes in the roof. Starting from the front, place the Cover Plate (Item 5) on top of the Foot Rails as shown and loosely fasten the Foot Rails to the vehicle using the M6 x 20 Hex Bolts, M6 x 19 Flat Washers and M6 Spring Washers (Items 2, 3, 4). Line up the joint from Step 2C and fasten. Push the Foot Rails towards the rear of the vehicle and tighten all bolts securing the Foot Rails to the vehicle. Place a M6 Nut Cap over each of the Hex Bolts securing the Foot Rails to the vehicle and the Nyloc Nuts used to fasten the Joiner plates.



3 FIT THE LOAD BARS

- (A) Referring to the Fitting Instruction received with your Load Bar Adapters (Document RRAC083), fit the Load Bars to the Foot Rails in the positions as shown below.

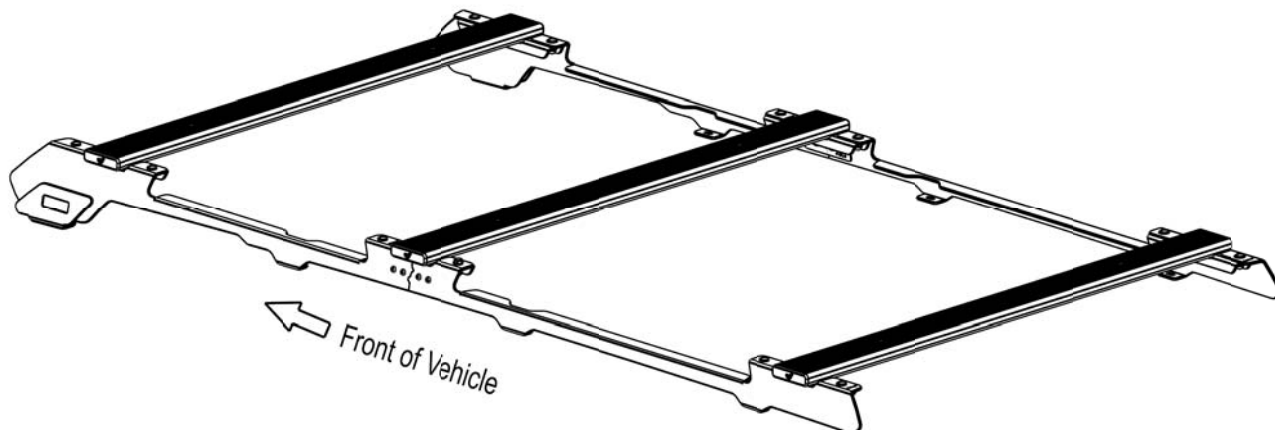

- (B) Congratulations, you have completed your installation. Take a step back and admire your work. Good Job!

4 TAKE A TRIP

- (A) After your first adventure, check that all nuts, bolts, screws and fittings are tight. Re-tighten where needed. You'll find a small amount of settling has happened.

Go on many more adventures, periodically checking all nuts, bolts, screws and fittings.



Front Runner can not recommend a maximum load carrying capacity. Please refer to your vehicle manufacturer's recommendations.