

FRONT RUNNER

**SLIMLINE II TRAY
UNIVERSAL ASSEMBLY
INSTRUCTIONS**

RRSTUNI

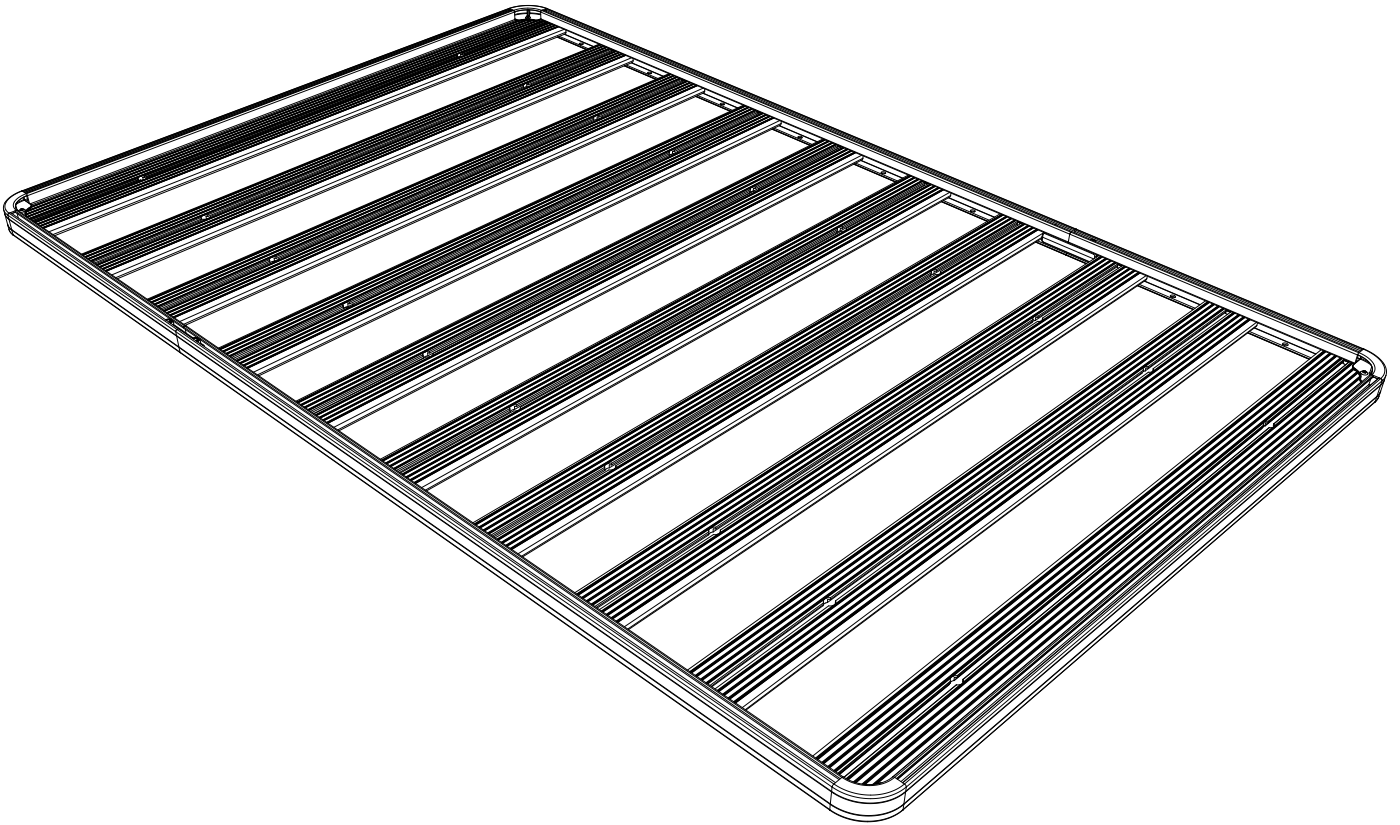

READ ME ! ⚠

Thank you for purchasing a Front Runner Slimline II Tray.

Before you start, take a moment to familiarize yourself with the Fitting Instructions and the components received.

Refer to Page 2 for a list of all the components, quantities and tools required.

IMPORTANT WARNING! ⚠

IT IS CRITICAL THAT ALL FRONT RUNNER PRODUCTS BE PROPERLY AND SECURELY ASSEMBLED AND ATTACHED TO YOUR VEHICLE. IMPROPER ATTACHMENT COULD RESULT IN AN AUTOMOBILE ACCIDENT, AND COULD CAUSE SERIOUS BODILY INJURY OR DEATH. YOU ARE RESPONSIBLE FOR ASSEMBLING AND SECURING ALL FRONT RUNNER PRODUCTS TO YOUR VEHICLE, CHECKING THE ATTACHMENTS PRIOR TO USE, AND PERIODICALLY INSPECTING THE PRODUCTS FOR ADJUSTMENT, WEAR AND DAMAGE. THEREFORE, YOU MUST READ AND UNDERSTAND ALL OF THE INSTRUCTIONS AND PRECAUTIONS SUPPLIED WITH YOUR FRONT RUNNER PRODUCT PRIOR TO INSTALLATION OR USE. IF YOU DO NOT UNDERSTAND ALL OF THE INSTRUCTIONS AND CAUTIONS, OR IF YOU HAVE NO MECHANICAL EXPERIENCE AND ARE NOT THOROUGHLY FAMILIAR WITH THE INSTALLATION PROCEDURES, YOU SHOULD HAVE THE PRODUCT INSTALLED BY A PROFESSIONAL INSTALLER OR OTHER QUALIFIED PERSONNEL.

NOTE: Front Runner will not be responsible for any damage caused by the failure to install the product according to these instructions.

1 GET ORGANIZED

Depending on which size Slimlime II Tray you order, quantities may vary from those pictured.

Here is what you are looking at for RRSUNI:

IN THE BOX

1	32 X	M8 Nyloc Nut
2	4 X	M8 x45 Button Head Bolt
3	2 X	Thick Joiner Piece
4	2 X	Thin Joiner Piece
5	4 X	Side Profile
6	4 X	Corner
7	2 X	Combined Slat
8	28 X	M8 x 25 Button Head Bolt
9	12 X	Standard Slat
10	4 X	M6 x 10 Button Head Bolt

TOOLS NEEDED

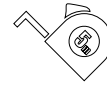
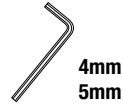
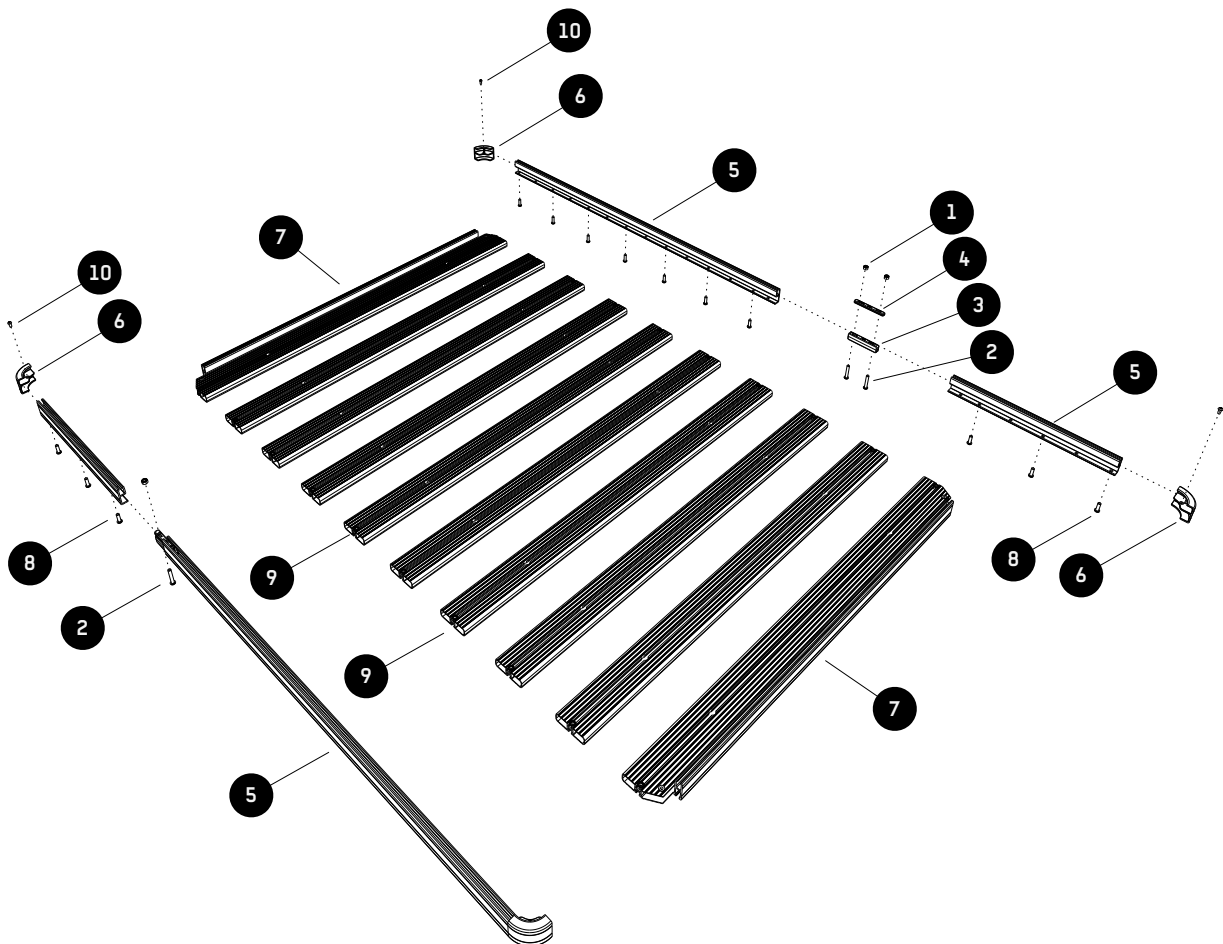

FIGURE 1.1





NOTE: Skip this step if your Slimline II Tray is 1560mm or shorter. you will only have two Side Profiles and assembly is not required.

If you have received four lengths of Side Profile (Item 5), you will need to join the pieces together using the Joiners (Items 3 & 4) to form only two lengths by following the easy steps below.

With the exception of the 2772mm long Slimline II Tray, the joints in the Side Profile will be diagonally opposite each other once the Tray is assembled.

2.1

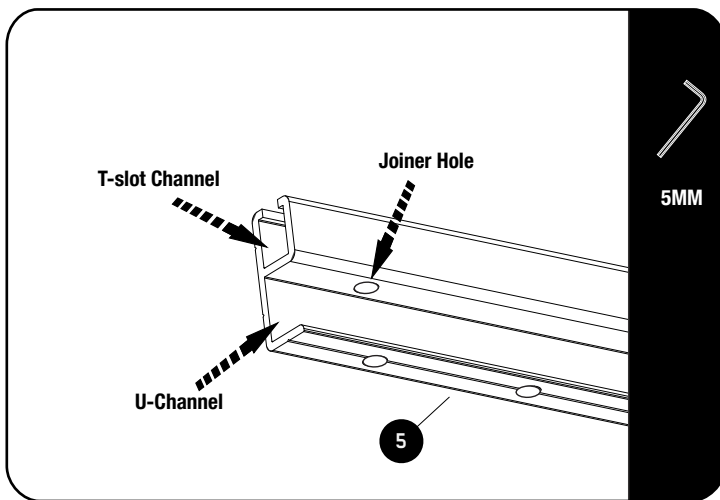

The Side Profiles are supplied in pairs. Take one profile from each pair, one short and one long (Except for the 2772mm long Slimline II rack where the Side Profiles will be equal length. Even though both pairs are the same length it is still important that you take one Side Profile from each pair).

If you look at the Side Profiles you will see that at one end there is a hole that goes through the top and bottom of the "U" Channel.

(Refer to Image 2.1). These are the Joiner Holes that you will be using.

2.2

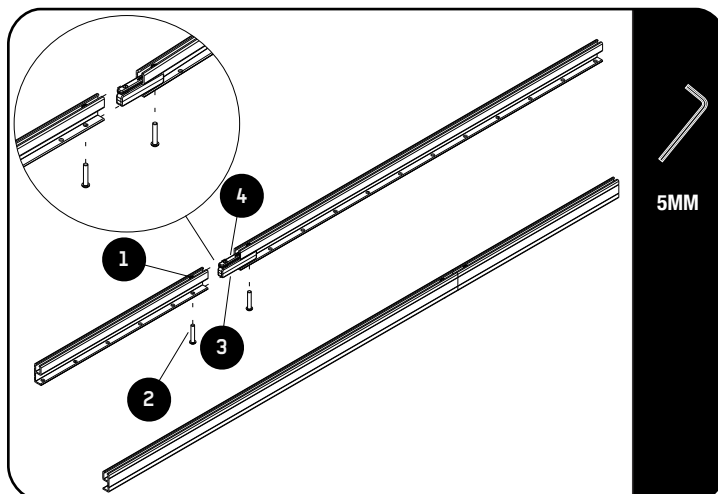

Insert a Thick Joiner (Item 3) into the "U" Channel of the Side Profile lining up the first hole with the hole in the side profile as show in 2.2.

Now grab a Thin Joiner (Item 4) and Nyloc Nut (Item 1). Slide the Joiner into the "T-slot", followed by a Nyloc Nut. The Nyloc Nut should sit on top of the Thin Joiner with the "Dome" of the Nyloc Nut facing up. Line up the outer hole of the Thin Joiner and Nyloc Nut with the Joiner Hole and loosely fasten it all together using a M8 x 45 Button Head Bolt (Item 2) and a 5mm Allen Wrench.

Slide the matching Side Profile over the two Joiner pieces, remembering to insert a Nyloc Nut, and fasten once again using a M8 x 45 Button Head Bolt. Repeat the above steps for the other side.

3

RACK ASSEMBLY - COMBINED SLATS AND STANDARD SLATS

3.1

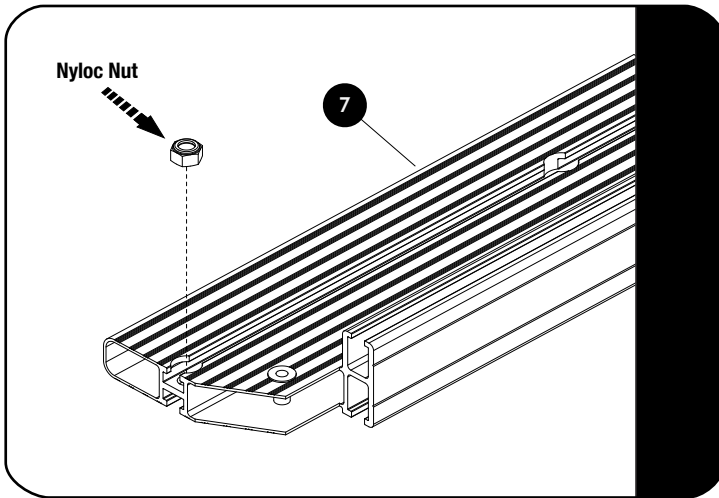

Look at the Combined Slats and Standard Slats (Item 7 & 9) and ensure that there is a Nyloc Nut inserted into each machined end pocket. If the Nyloc Nut has fallen out during shipping, insert it back into the pocket as shown.

3.2

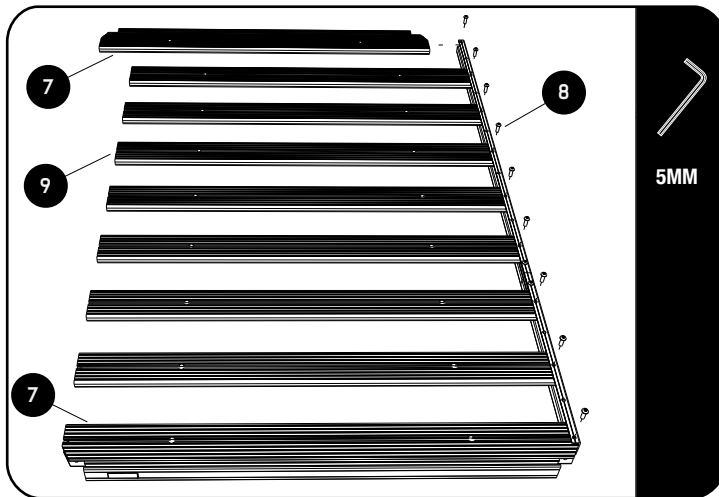

Turn the Combined Slat (Item 7) and the Side Profile Assembly upside down. Ensure that the nut in the Combined Slat is at the bottom. Push the one end of the Combined Slat into the Side Profile assembly and align the holes.

Use a M8 x 25 Button Head (Item 8) and loosely tighten using a 5mm Allen Wrench.

Do the same with the second Combined Slat on the other end of the Side Profile Assembly.

Take a Standard Slat (Item 9) and as with the Combined Slat, slide the one end into the Side Profile Assembly as shown. Ensure that the nut is at the bottom.

Use a M8 x 25 Button Head Bolt (Item 8) and loosely fasten the Standard Slat to the Side Profile using a 5mm Allen Wrench.

Repeat the process for the remaining Standard Slats making sure that there is an open hole in the Side Profile in between each slat.

3.3

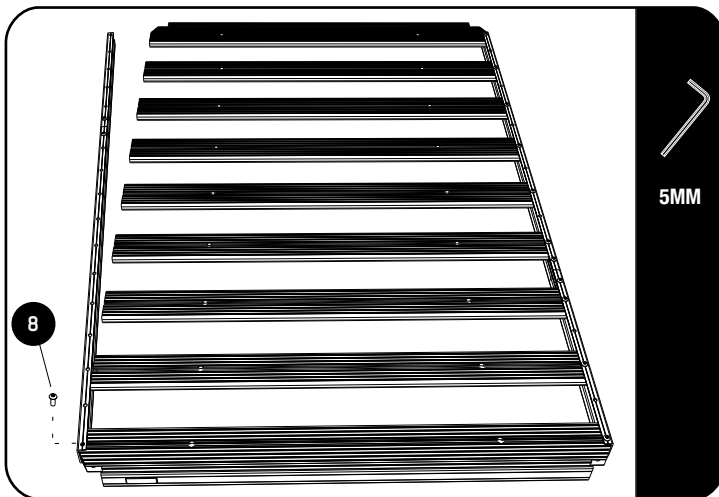

Take the other Side Profile Assembly and starting at the one end push the Side Profile over the ends of the Combined Slat and Standard Slats, aligning the holes and loosely inserting the M8 x 25 Button Heads as you work your way to the Combined Slat at the other end.

3**RACK ASSEMBLY - STANDARD SLATS**

3.4

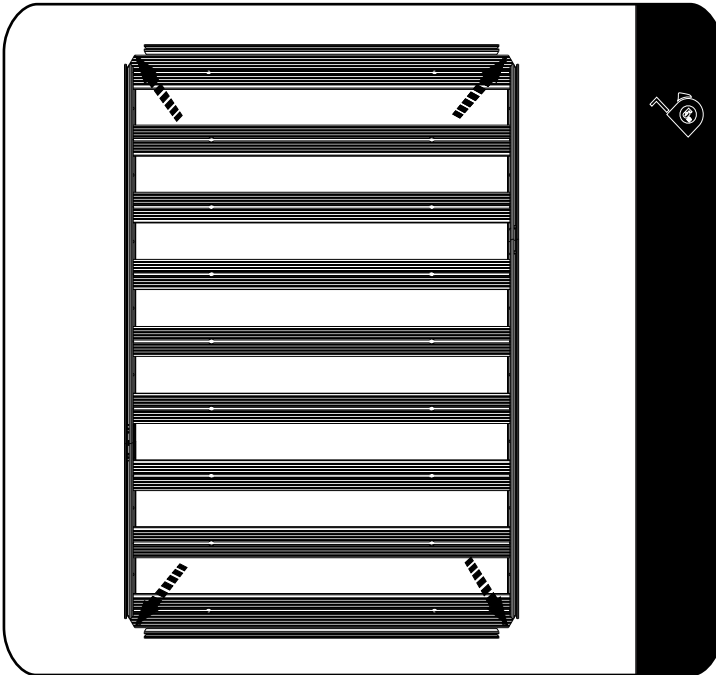

Square the Side Profiles and Slats up before fully tightening all the fasteners.

Using a tape measure, measure from the one corner across to the other corner. Do the same on the opposite corners, if the two measurements are the same the rack will be square.

Fully tighten all the M8 x 25 Button Head Bolts



The recommended torque setting for the M8 Button Head Bolts is 20 Nm or 15 ft lb.

4**RACK ASSEMBLY- CORNERS**

4.1



Flip the tray right side up.

Push the Corner into position as shown, aligning the hole in the Corner with the Rivnut already inserted in the Combined Slat. Use a M6 x 12 Button Head Bolt (Item 10) and fasten the Corner in position.

5

RACK ASSEMBLY - WIND DEFLECTOR

IN THE BOX

1	1	Slimline II Tray
2	4	M8 Half Nut
3	2	Wind Deflector (1LH + 1RH)
4	4	Schnorr Washer
5	4	M8 x 12 Button Head Bolt

TOOLS NEEDED



5mm

FIGURE 1.2

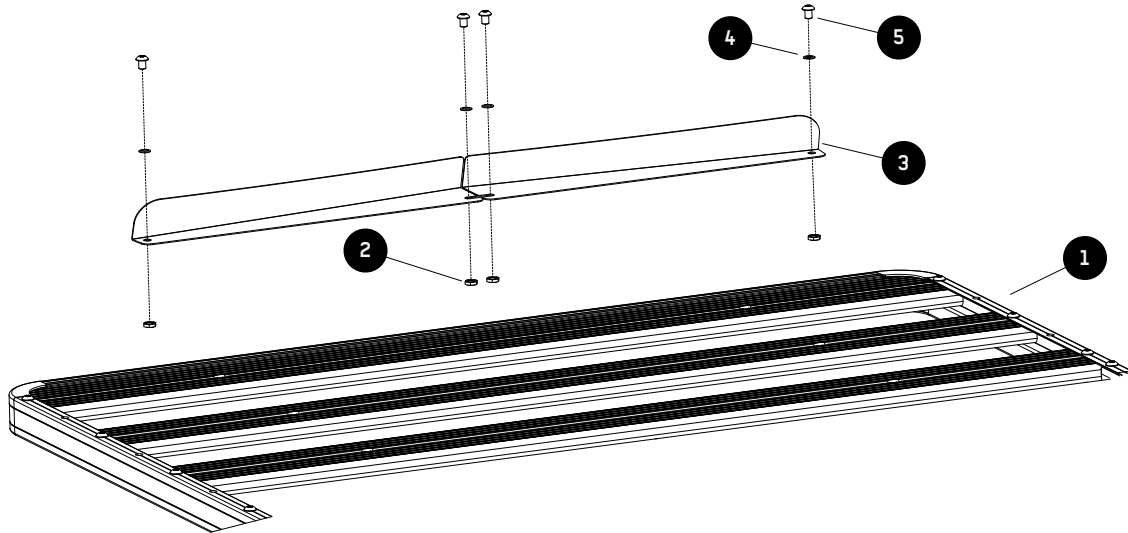

6

RACK ASSEMBLY - WIND DEFLECTOR



NOTE : The Wind Deflector must be fitted to the underside of the front Combined Slat.

If you are going to put a Leg or Foot on the Combined Slat (Recommended), you will need to slide the M8 Bolt used for attaching these into the Machined Slots before assembling the Wind Deflector.

6.1



Ensure that your Slimline II Tray is upside down. Check by looking at the product sticker. It should be upside down as shown.

6.2

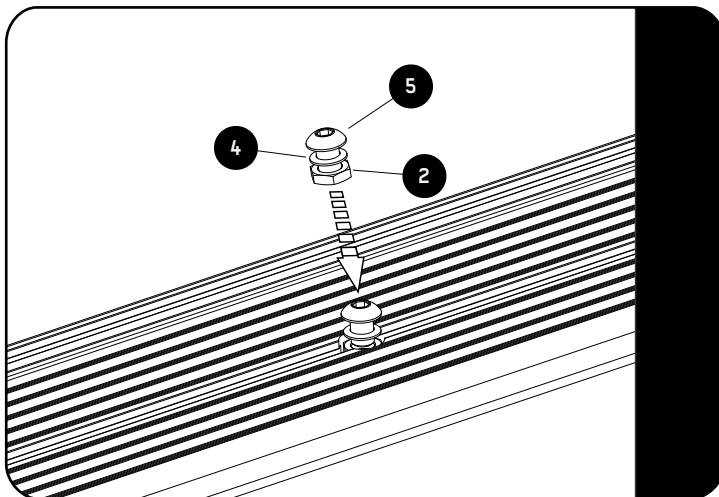

Insert two Button Head Bolts, M8 Half Nuts and Schnorr Washers (Items 2, 4 & 5) assemblies into the Combined Slat as shown. Slide them to the center of the Combined Slat making sure that the Schnorr Washer is above the T-slot Channel.

6.3

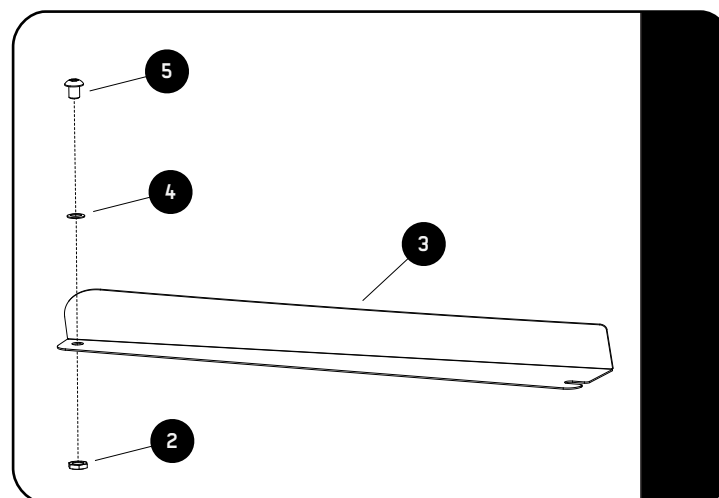

Assemble Items 2, 4 & 5 to both LH & RH Wind Deflectors (Item 3) as shown.

6

RACK ASSEMBLY - WIND DEFLECTOR

6.4

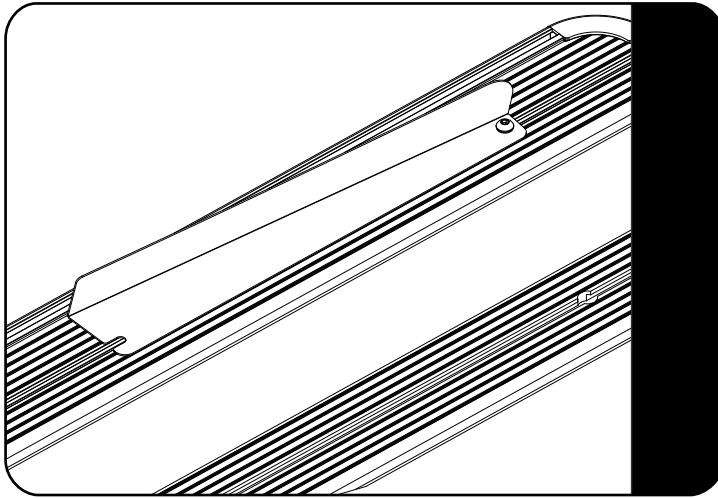

Insert the nut assembled to the Wind Deflector in the Combined Slat T-slot Pocket and slide to the side as shown in Figure 8.4.

Repeat for the other half of the Wind Deflector.

6.5

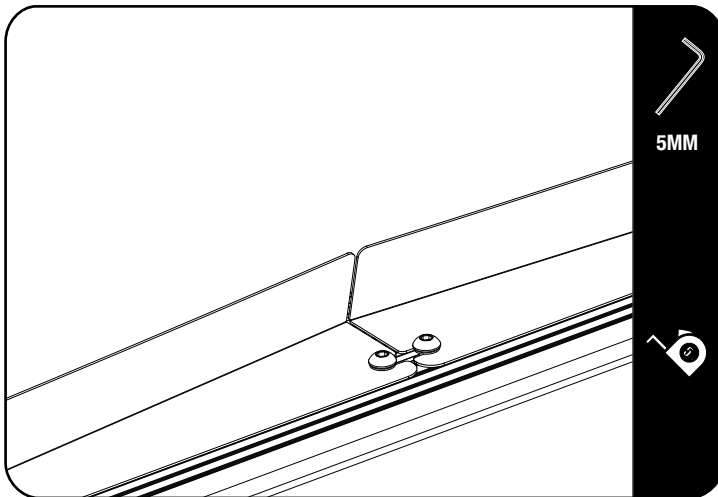

Center the Wind Deflector on the rack and move the bolt assemblies from Figure 8.2 into the slots as shown in Figure 8.5.



NOTE : Once the rack is fitted to the vehicle, take it for a test drive. Should there be excessive wind noise try moving the two Wind Deflectors slightly apart, leaving a gap of about 20 - 30mm.



USEFULL TIP - PRE-LOAD TIE DOWN RINGS

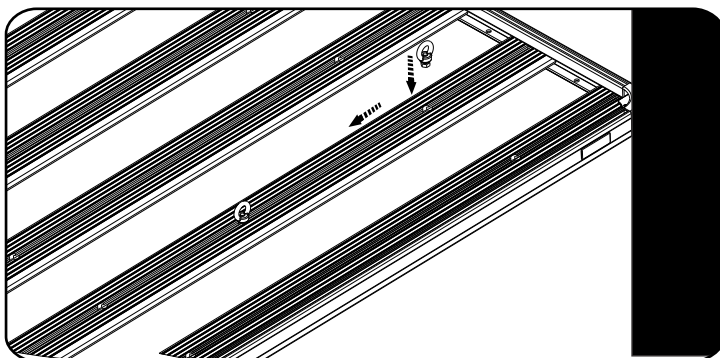

It is useful to fit Tie-Down Rings (RRAC012) to your Front Runner Rack for future use before you fit any accessories.

Insert the Tie Down Rings into the machined slots and position them in the center of the rack.

7

CHECK YOUR VEHICLE INSTALLATION GUIDE

7.1

Now that your Slimline II Tray is assembled, get your Rack Kit Installation Guide out and follow the instructions to fit the Slimline II Tray to your specific vehicle.

8

HOW TO CARE FOR YOUR FRONT RUNNER GEAR

FRONT RUNNER RACKS AND ACCESSORIES ARE HAPPIEST COVERED IN MUD

But in order to maintain full functionality of the rack slots and any moving parts, you may want to give your gear a bath now and again.

It's easy! Take care of your Front Runner gear the same way you do the exterior of your vehicle:

Rinse with clean water and wipe down with a soft dry cloth. For stubborn spots, use a soft brush and mild soap.

If you really want to baby your gear, feel free to lightly wax the surfaces or use a protective spray with UV inhibitors. Just be sure not to use compound waxes that contain abrasives.

In salty coastal climates, or snowy regions where salt is used to clear roadways, applying a silicone based oil or spray to nuts and bolts will help prevent corrosion.

WHETHER YOU LIKE TO ROLL DIRTY OR CLEAN, YOUR FRONT RUNNER GEAR WILL GIVE YOU MANY YEARS OF SERVICE!

9

INSTALL OTHER VEHICLE AND RACK ACCESSORIES

Now's the time to visit your favorite Front Runner Dealer in person or online.

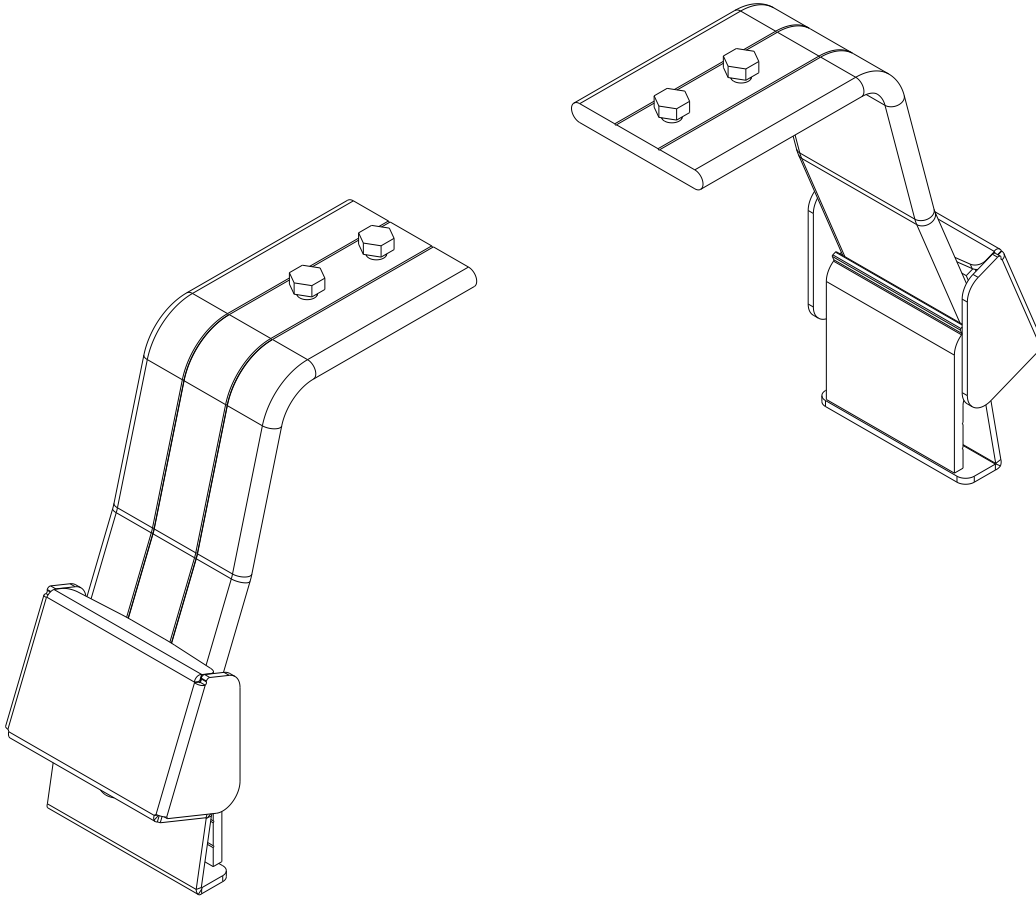

READ ME !

Thank you for purchasing a Front Runner Leg Assembly.

Before you start, take a moment to familiarize yourself with the Fitting Instructions and the components received.

Refer to Page 2 for a list of all the components, quantities and tools required.

IMPORTANT WARNING!

IT IS CRITICAL THAT ALL FRONT RUNNER PRODUCTS BE PROPERLY AND SECURELY ASSEMBLED AND ATTACHED TO YOUR VEHICLE. IMPROPER ATTACHMENT COULD RESULT IN AN AUTOMOBILE ACCIDENT, AND COULD CAUSE SERIOUS BODILY INJURY OR DEATH. YOU ARE RESPONSIBLE FOR ASSEMBLING AND SECURING ALL FRONT RUNNER PRODUCTS TO YOUR VEHICLE, CHECKING THE ATTACHMENTS PRIOR TO USE, AND PERIODICALLY INSPECTING THE PRODUCTS FOR ADJUSTMENT, WEAR AND DAMAGE. THEREFORE, YOU MUST READ AND UNDERSTAND ALL OF THE INSTRUCTIONS AND PRECAUTIONS SUPPLIED WITH YOUR FRONT RUNNER PRODUCT PRIOR TO INSTALLATION OR USE. IF YOU DO NOT UNDERSTAND ALL OF THE INSTRUCTIONS AND CAUTIONS, OR IF YOU HAVE NO MECHANICAL EXPERIENCE AND ARE NOT THOROUGHLY FAMILIAR WITH THE INSTALLATION PROCEDURES, YOU SHOULD HAVE THE PRODUCT INSTALLED BY A PROFESSIONAL INSTALLER OR OTHER QUALIFIED PERSONNEL.

NOTE: Front Runner will not be responsible for any damage caused by the failure to install the product according to these instructions.

1**GET ORGANIZED****IN THE BOX**

1	2 X	Leg
2	4 X	M8 x 25 Hex Bolt
3	4 X	M8 x 16 x 1.6SS Flat Washer
4	4 X	M8 Nyloc Nut
5	4 X	M8 Nut Cap
6	2 X	Gutter Clamp
7	2 X	M8 SS Spring Washer
8	2 X	M8 x 30 Button Head Bolt
9	2 X	Diagonal Leg

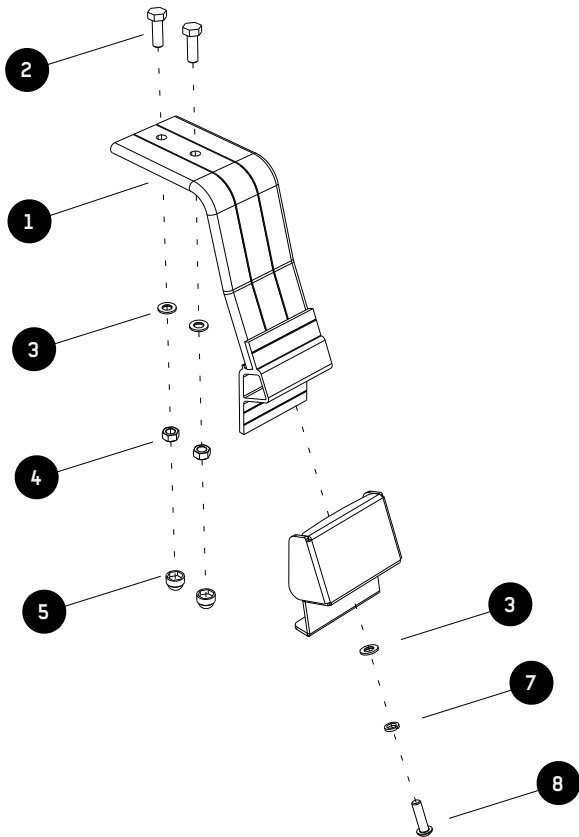
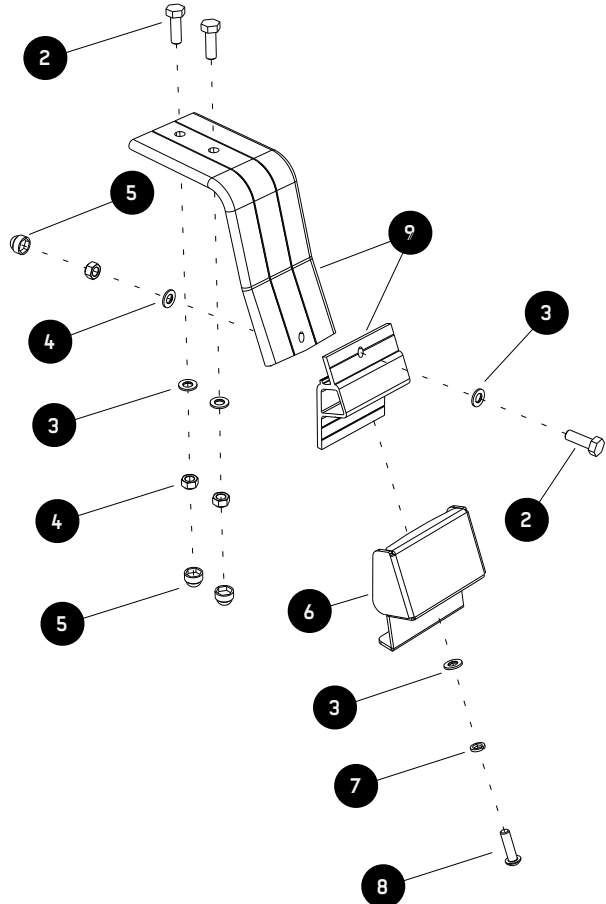
TOOLS NEEDED**FIGURE 1.1 - LEG****FIGURE 1.2 - DIAGONAL LEG**

2**FIT AND SECURE**

2.1

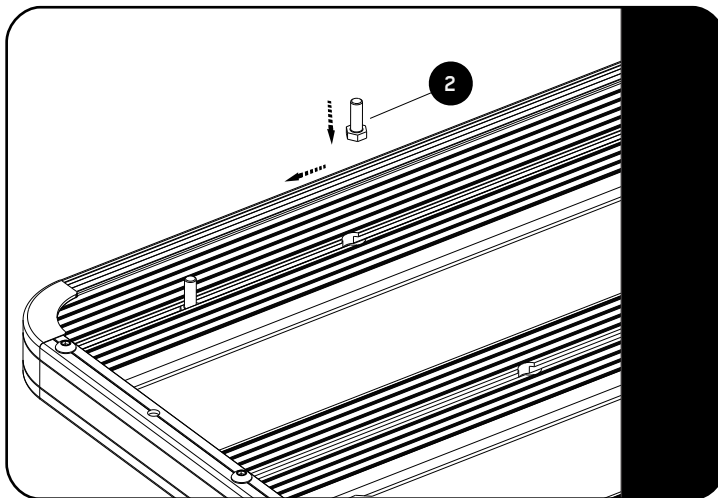

RECOMMENDED SPACING BETWEEN LEGS OR FEET ARE 3 SLATS.

SPACING MAY NOT EXCEED 4 SLATS.



Slide two M8 x 25 Hex Bolts (Item 2) into the Slats machined slots.

2.2

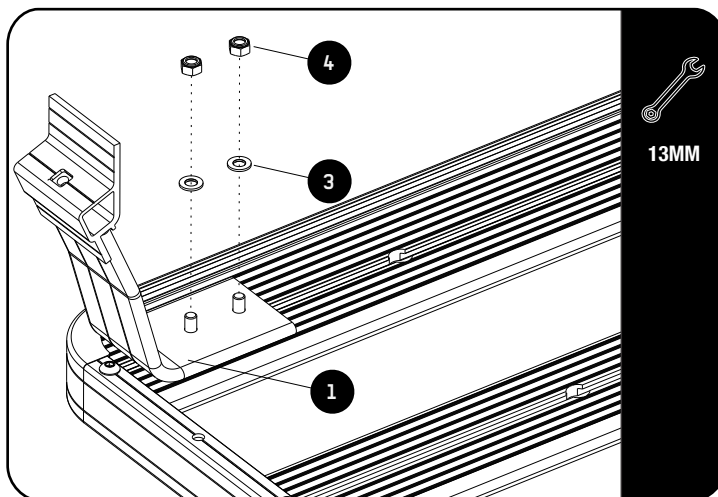

IF YOU ARE FITTING A DIAGONAL LEG, REFER TO FIGURE 1.2 FOR ASSEMBLY.



Loosely fit the Legs (Item 1 OR 9) using M8 x 16 x 1.6SS Flat Washers and M8 Nyloc Nuts (Items 3 & 4).

Place M8 Nut Caps (Item 5) on all the Nyloc Nuts after fully tightening.

2.3

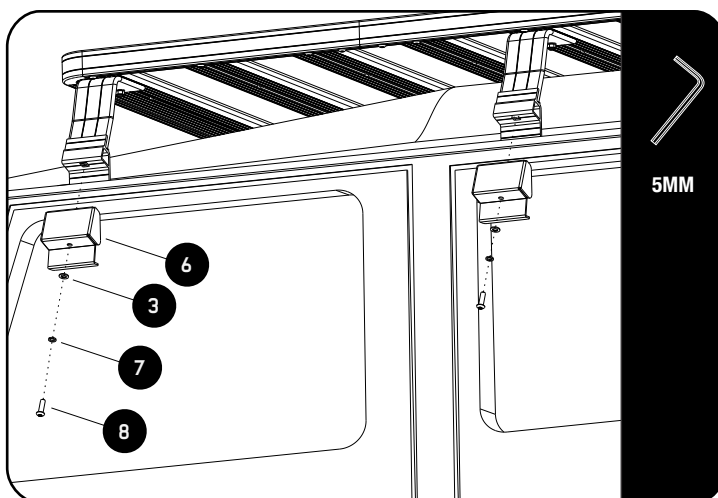

Secure the Gutter Clamps (Item 6) using M8 x 30 Button Heads, M8 SS Spring Washers and M8 x 16 x 1.6SS Flat Washers (Items 3, 7 & 8).

3

FINISH

Congratulations! You did it. Take a step back and admire your work!

4

INSTALL OTHER VEHICLE AND RACK ACCESSORIES

Now's the time to visit your favorite Front Runner Dealer in person or online.