



**FRONT RUNNER**

**FORD RANGER  
SLIMLINE II RACK  
( 1255MM X 1358MM )**

**KRFM005T**



**INSTALL TIME: 2.5 Hours**

# **START HERE**

## **READ ME FIRST**

Thank you for purchasing a Front Runner Slimline II Rack.

This Roof Rack consists of a kit that contains:

1. A Slimline II Tray
2. A mounting system specific to your vehicle

Before you start, take a moment and open all your boxes and gather the assembly instructions for the various components.

This document will guide you through the assembly of the various mounting system components and assist you in fitting the Slimline II Tray to your specific vehicle.

### **IMPORTANT WARNING!**

**IT IS CRITICAL THAT ALL FRONT RUNNER PRODUCTS BE PROPERLY AND SECURELY ASSEMBLED AND ATTACHED TO YOUR VEHICLE. IMPROPER ATTACHMENT COULD RESULT IN AN AUTOMOBILE ACCIDENT, AND COULD CAUSE SERIOUS BODILY INJURY OR DEATH TO YOU OR TO OTHERS. YOU ARE RESPONSIBLE FOR ASSEMBLING AND SECURING ALL FRONT RUNNER PRODUCTS TO YOUR VEHICLE, CHECKING THE ATTACHMENTS PRIOR TO USE, AND PERIODICALLY INSPECTING THE PRODUCTS FOR ADJUSTMENT, WEAR, AND DAMAGE. THEREFORE, YOU MUST READ AND UNDERSTAND ALL OF THE INSTRUCTIONS AND CAUTIONS SUPPLIED WITH YOUR FRONT RUNNER PRODUCT PRIOR TO INSTALLATION OR USE. IF YOU DO NOT UNDERSTAND ALL OF THE INSTRUCTIONS AND CAUTIONS, OR IF YOU HAVE NO MECHANICAL EXPERIENCE AND ARE NOT THOROUGHLY FAMILIAR WITH THE INSTALLATION PROCEDURES, YOU SHOULD HAVE THE PRODUCT INSTALLED BY A PROFESSIONAL INSTALLER OR OTHER QUALIFIED PERSONNEL.**

1

## MOUNT YOUR TRACKS

REFER TO TRACK MOUNTING INSTRUCTIONS (DOCUMENT TRFR001)

2

## ASSEMBLE YOUR SLIMLINE II RACK

REFER TO SLIMLINE II TRAY UNIVERSAL ASSEMBLY INSTRUCTION (DOCUMENT RRSUNI)

3

## FIT THE FEET

REFER TO FOOT ASSEMBLY & SLIMLINEII TRAY FOOT ADAPTER INSTRUCTIONS (DOCUMENT FASSUNI & RRAC021)

- (A) With your Rack in the upside down position (Product sticker should be upside down), fit the Foot Adapter Plates and top of the Feet to your Slimline II Tray as illustrated below.

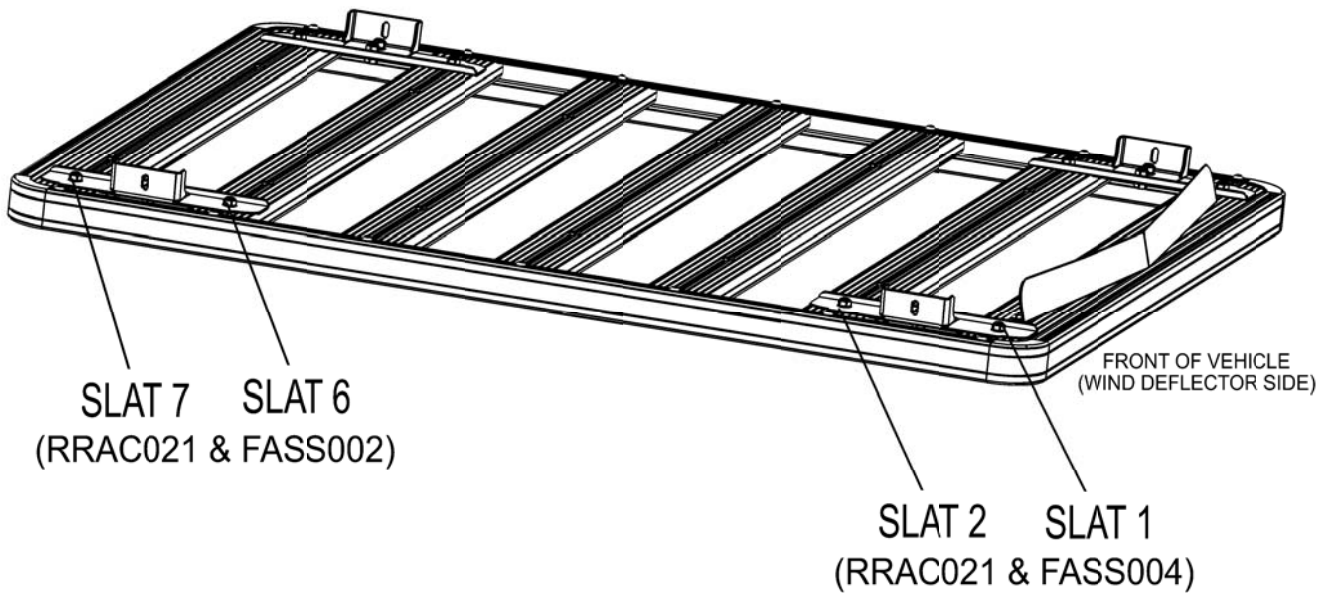

**NOTE:** DO NOT SLIDE THE RACK AND FEET ACROSS THE ROOF! If there is a chance that you are going to set the roof rack on to the roof, place some moving blankets and/or towels over the roof. If you must lower the rack before it is in position, carefully set the Feet on the padded surface.



Once your Slimline II Roof Rack is fitted, ensure a 15mm clearance is maintained between the Wind Deflector and the vehicles roof otherwise damage to the roof may occur. Bend the Wind Deflector by hand if necessary.

## **4 MOUNT THE RACK TO YOUR VEHICLE**

REFER TO FOOT ASSEMBLY INSTRUCTION (DOCUMENT FASSUNI)

- ( **A** ) Insert the required Bottom Feet into each Track and space according to the distances between the Top Feet fitted to the Rack in Step 3 (Document FASSUNI).

Grab your friend and with one of you on each side of the Rack, flip the rack end over end (Prevents the Hex Bolts from falling out the machines slots) so that the Feet are facing down. With the Wind Deflectors facing forward, approach the vehicle from the rear lifting the Rack up and over the roof.

Position the Rack as far back as possible without it overhanging the rear of the vehicle. Bring the rack down slowly lining up the Top and Bottom Feet and loosely fasten.

Center the Rack left to right. Ensure that the Rack is level - front to back and left to right - before tightening.



**Congratulations, you have completed your installation. Take a step back and admire your work. Good Job!**

## **5 TAKE A TRIP**

- ( **A** ) After your first adventure, check that all nuts, bolts, screws and fittings are tight. Re-tighten where needed. You'll find a small amount of settling has happened.

Go on many more adventures, periodically checking all nuts, bolts, screws and fittings.



**Front Runner can not recommend a maximum load carrying capacity. Please refer to your vehicle manufacturer's recommendations.**

# FRONT RUNNER

**FOOT**  
**(40MM - 50MM, 60MM - 70MM)**  
**(ANGLED 65MM & ANGLED 75MM)**

FASSUNI

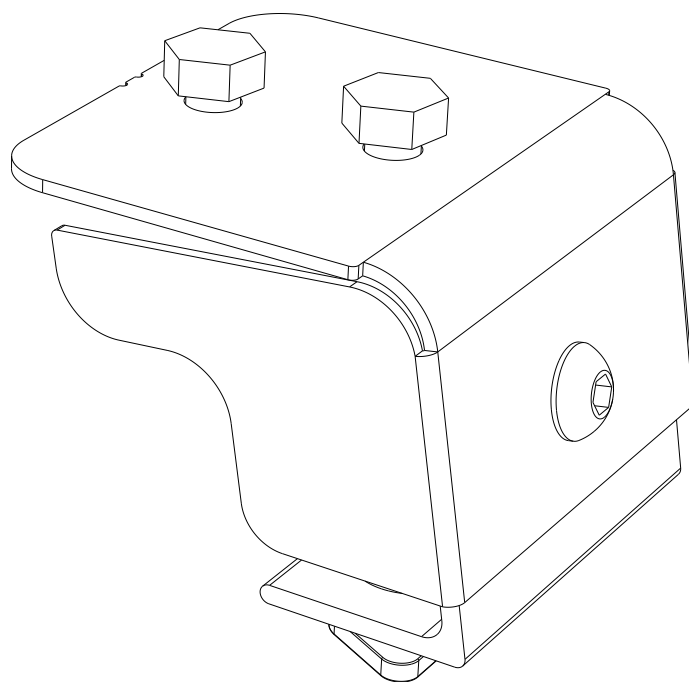
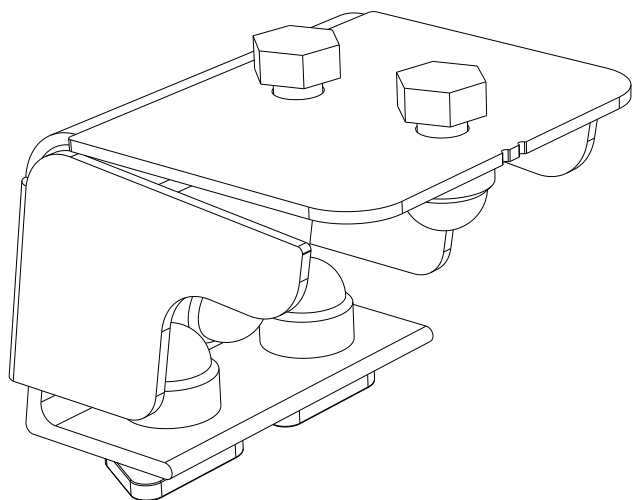

## READ ME !

Thank you for purchasing a Front Runner Foot Set.

Before you start, take a moment to familiarize yourself with the Fitting Instructions and the components received.

Refer to Page 2 for a list of all the components, quantities and tools required.

## IMPORTANT WARNING!

IT IS CRITICAL THAT ALL FRONT RUNNER PRODUCTS BE PROPERLY AND SECURELY ASSEMBLED AND ATTACHED TO YOUR VEHICLE. IMPROPER ATTACHMENT COULD RESULT IN AN AUTOMOBILE ACCIDENT, AND COULD CAUSE SERIOUS BODILY INJURY OR DEATH. YOU ARE RESPONSIBLE FOR ASSEMBLING AND SECURING ALL FRONT RUNNER PRODUCTS TO YOUR VEHICLE, CHECKING THE ATTACHMENTS PRIOR TO USE, AND PERIODICALLY INSPECTING THE PRODUCTS FOR ADJUSTMENT, WEAR AND DAMAGE. THEREFORE, YOU MUST READ AND UNDERSTAND ALL OF THE INSTRUCTIONS AND PRECAUTIONS SUPPLIED WITH YOUR FRONT RUNNER PRODUCT PRIOR TO INSTALLATION OR USE. IF YOU DO NOT UNDERSTAND ALL OF THE INSTRUCTIONS AND CAUTIONS, OR IF YOU HAVE NO MECHANICAL EXPERIENCE AND ARE NOT THOROUGHLY FAMILIAR WITH THE INSTALLATION PROCEDURES, YOU SHOULD HAVE THE PRODUCT INSTALLED BY A PROFESSIONAL INSTALLER OR OTHER QUALIFIED PERSONNEL.

**NOTE: Front Runner will not be responsible for any damage caused by the failure to install the product according to these instructions.**



CHECK ONLINE FOR LATEST FITMENT GUIDE

# 1 GET ORGANIZED

## IN THE BOX

1	2 X	Foot Top
2	2 X	Foot Base
3	4 X	M8 x 20 T-Bolt
4	4 X	M8 x 16 Hex Bolt
5	2 X	M8 x 16 Button Head Bolt
6	2 X	M8 x 16 x 1.6 Flat Washer
7	10 X	M8 Nyloc Nut
8	10 X	M8 Nut Cap

## TOOLS NEEDED



FIGURE 1.1

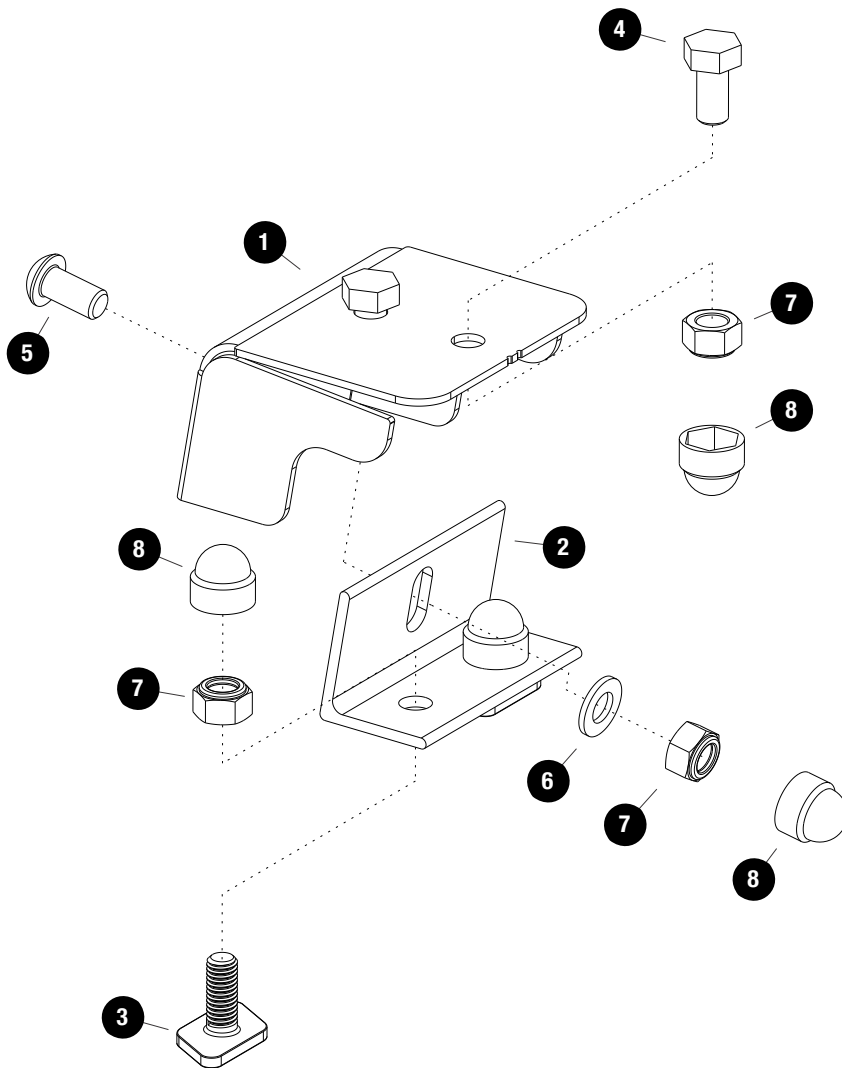

Angled Foot

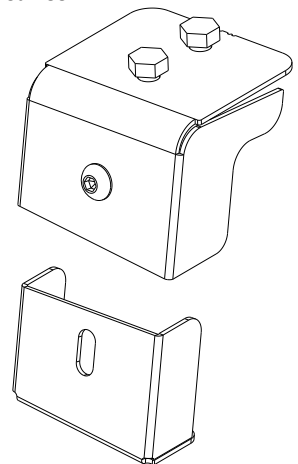

Angled Foot Base

2.1

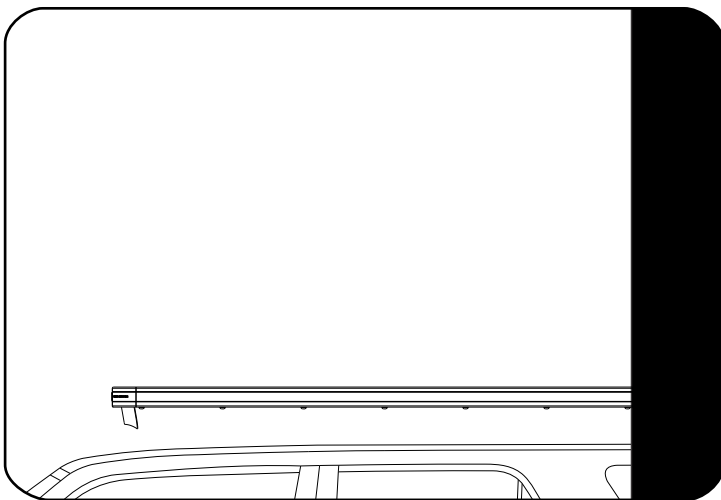

Place your Front Runner Roof Rack over your vehicle and find the best position. The Rack should sit level to the ground, not the vehicles roof line, or slanting slightly down toward the front.

Find the best position for the Feet, using the Combined Slat or Second Slat (Combined Slat recommended).

Remove the Rack and find a suitable surface to do the assembly.

Flip the Rack so that the bottom of the Rack faces up. Insert two M8 x 16 Hex Bolts (Item 4) into the Slats machined slots that you have identified.

2.2

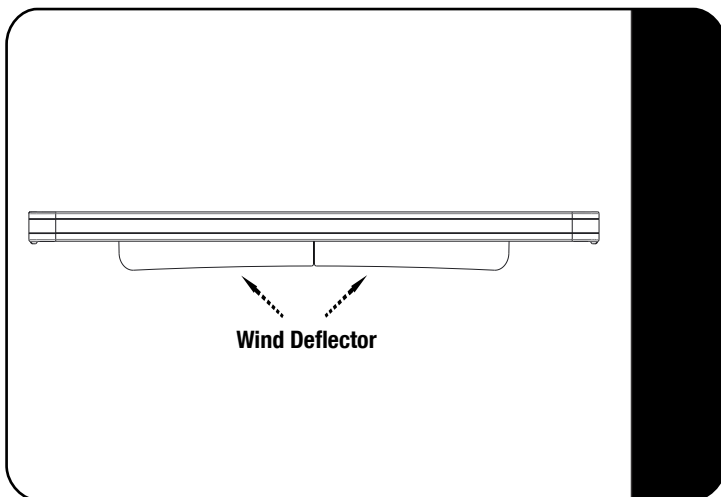

While your Rack is flipped make sure that the wind deflector is installed on the first slat.

2.3

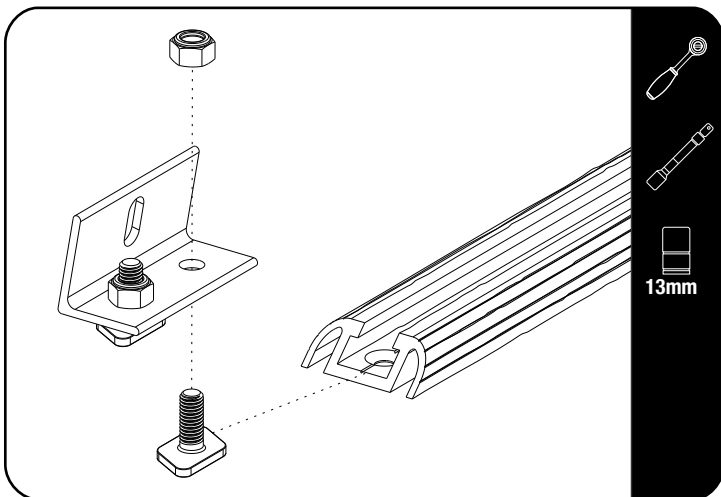

Slide the M8 x 20 T-Bolts (Item 3) into the track as shown, assemble the Foot Base (Item 2) using M8 x 20 T-Bolts and M8 Nyloc Nuts (Items 3 & 7).



Fully tighten and then loosen slightly to allow the foot base to slide in the track.

2.4

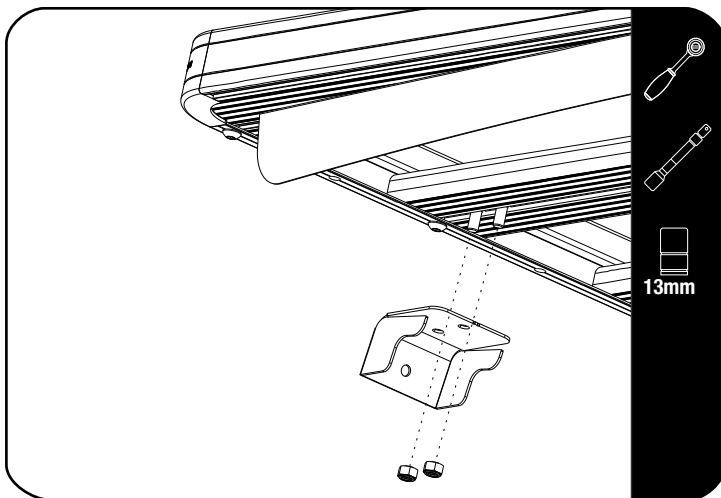

Assemble the Foot Top (Item 1) to the Rack as shown using M8 x 20 Hex Bolts inserted earlier in 2.1 and M8 Nyloc Nuts (Items 4 & 7).



Do not fully tighten to allow for the Foot tops to slide in the slats T-slot.

2.5

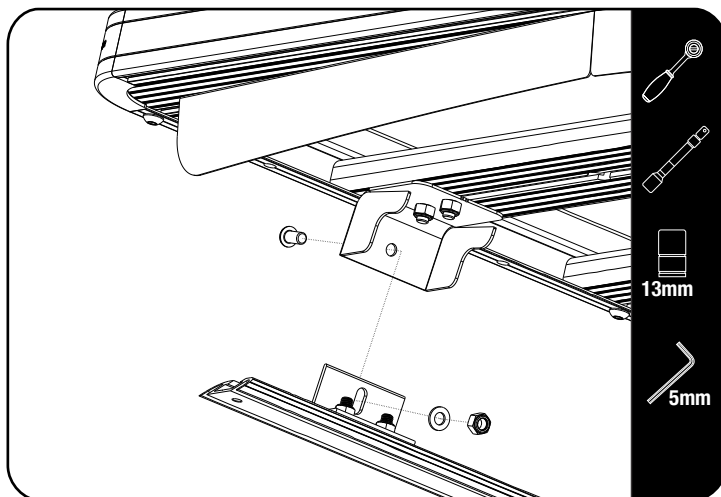

Position the Rack over the Foot Bases. Assemble using, M8 x 16 Button Head Bolts, M8 x 16 x 1.6 Flat Washers & M8 Nyloc Nuts (Items 5, 6 & 7).



Do not fully tighten to allow the Foot height to be adjusted if required.

2.6

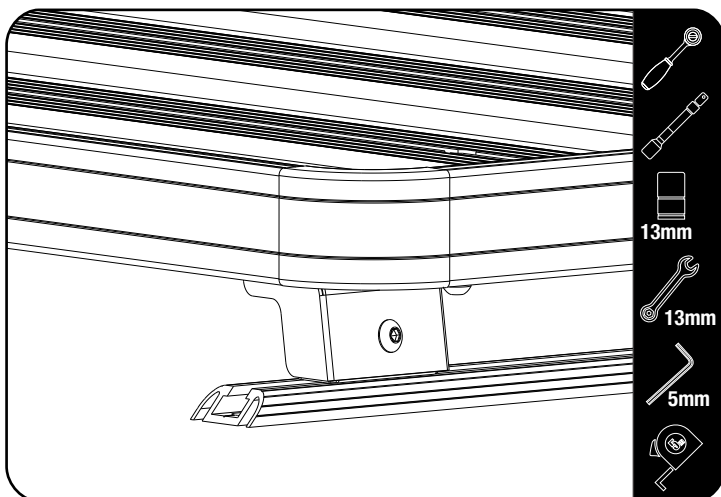

Before tightening the Foot Base to the tracks, position the Rack so that it sits level to the ground, not the vehicle's roof line, or slanting slightly down toward the front.

First tighten the Feet to the tracks using a 13mm wrench, then center the Rack left to Right and fully tighten the fasteners from 2.4.

Lastly set the height and fully tighten the M8 x 16 Button Head Bolts and M8 Nyloc Nuts (Items 5 & 7).



Fully tighten the Nyloc Nut using the Socket and holding the Button Head with the Allen Key.



Tightening Torque 20Nm or 15 ft lb

Check clearance with sunroof operation and any accessories fitted.

25mm clearance is needed between roof and table bracket, if fitted.

**3**

## **FINISH**

**Congratulations! You did it. Take a step back and admire your work!**

**4**

## **INSTALL OTHER VEHICLE AND RACK ACCESSORIES**