



READ ME ! 

Thank you for purchasing a Front Runner Slimline II Tray.

Before you start, take a moment to familiarize yourself with the Fitting Instructions and the components received.

Refer to Page 2 for a list of all the components, quantities and tools required.

IMPORTANT WARNING! 

IT IS CRITICAL THAT ALL FRONT RUNNER PRODUCTS BE PROPERLY AND SECURELY ASSEMBLED AND ATTACHED TO YOUR VEHICLE. IMPROPER ATTACHMENT COULD RESULT IN AN AUTOMOBILE ACCIDENT, AND COULD CAUSE SERIOUS BODILY INJURY OR DEATH. YOU ARE RESPONSIBLE FOR ASSEMBLING AND SECURING ALL FRONT RUNNER PRODUCTS TO YOUR VEHICLE, CHECKING THE ATTACHMENTS PRIOR TO USE, AND PERIODICALLY INSPECTING THE PRODUCTS FOR ADJUSTMENT, WEAR AND DAMAGE. THEREFORE, YOU MUST READ AND UNDERSTAND ALL OF THE INSTRUCTIONS AND PRECAUTIONS SUPPLIED WITH YOUR FRONT RUNNER PRODUCT PRIOR TO INSTALLATION OR USE. IF YOU DO NOT UNDERSTAND ALL OF THE INSTRUCTIONS AND CAUTIONS, OR IF YOU HAVE NO MECHANICAL EXPERIENCE AND ARE NOT THOROUGHLY FAMILIAR WITH THE INSTALLATION PROCEDURES, YOU SHOULD HAVE THE PRODUCT INSTALLED BY A PROFESSIONAL INSTALLER OR OTHER QUALIFIED PERSONNEL.

NOTE: Front Runner will not be responsible for any damage caused by the failure to install the product according to these instructions.
Please call us if you have any questions about the installation of this product.

1 GET ORGANIZED

Depending on which size Slimlime II Tray you order, quantities may vary from those pictured.

Here is what you are looking at for RRSUNI:

IN THE BOX

1	32 X	M8 Nyloc Nut
2	4 X	M8 x45 Button Head Bolt
3	2 X	Thick Joiner Piece
4	2 X	Thin Joiner Piece
5	4 X	Side Profile
6	4 X	Corner
7	2 X	Combined Slat
8	28 X	M8 x 25 Button Head Bolt
9	12 X	Standard Slat
10	4 X	M6 x 10 Button Head Bolt

TOOLS NEEDED

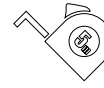
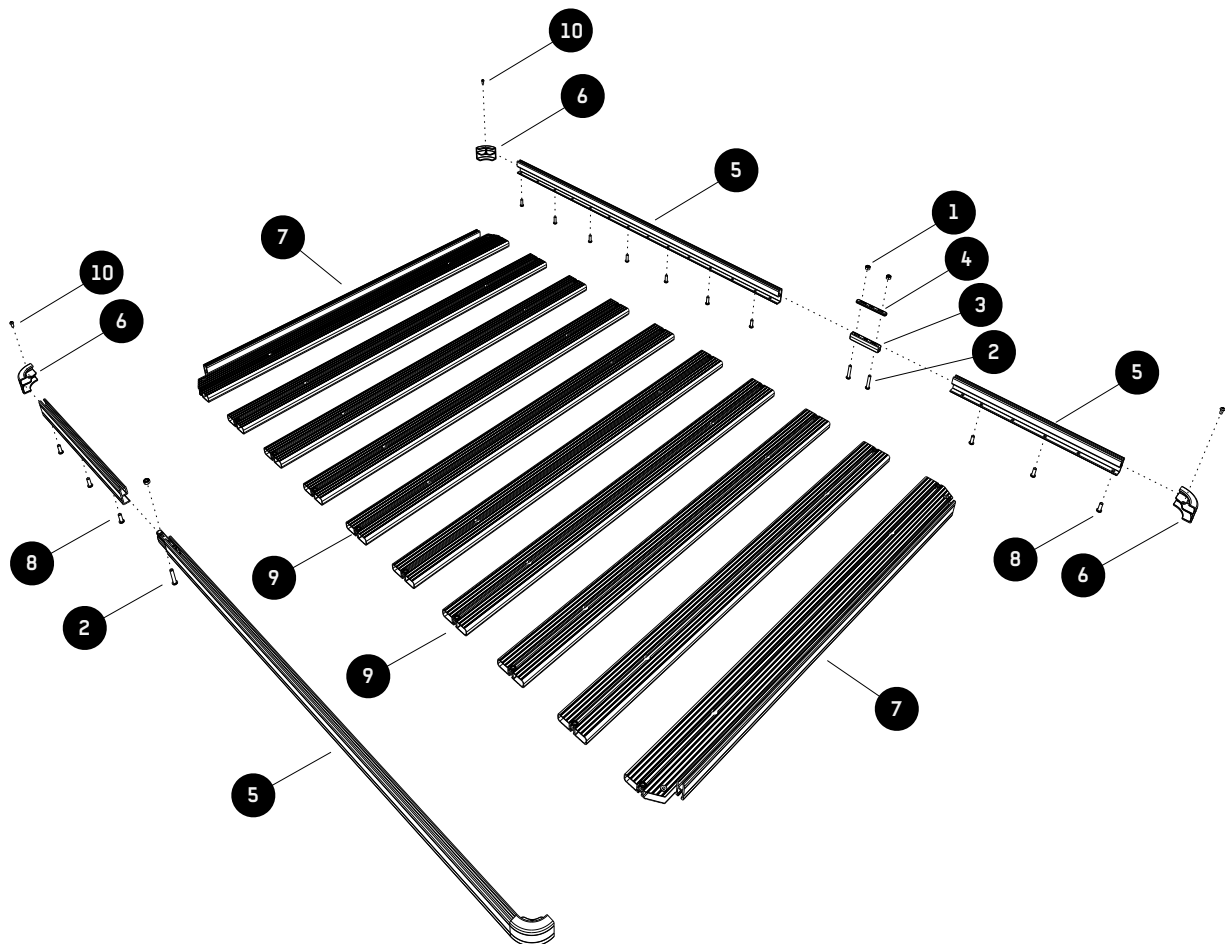


FIGURE 1.1



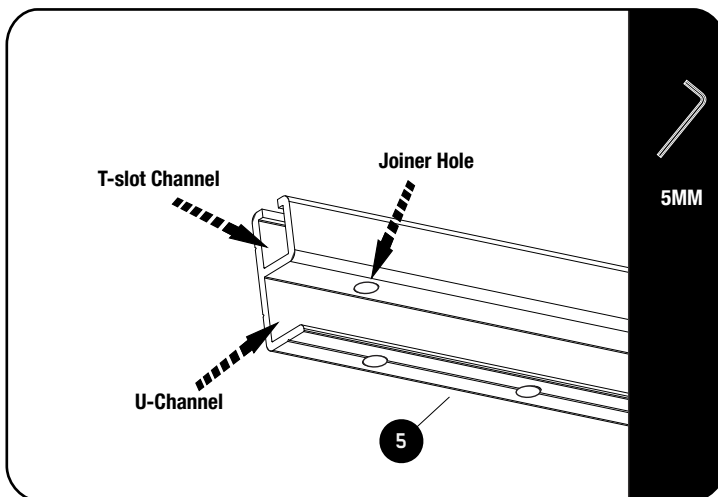


NOTE: Skip this step if your Slimline II Tray is 1560mm or shorter. you will only have two Side Profiles and assembly is not required.

If you have received four lengths of Side Profile (Item 5), you will need to join the pieces together using the Joiners (Items 3 & 4) to form only two lengths by following the easy steps below.

With the exception of the 2772mm long Slimline II Tray, the joints in the Side Profile will be diagonally opposite each other once the Tray is assembled.

2.1

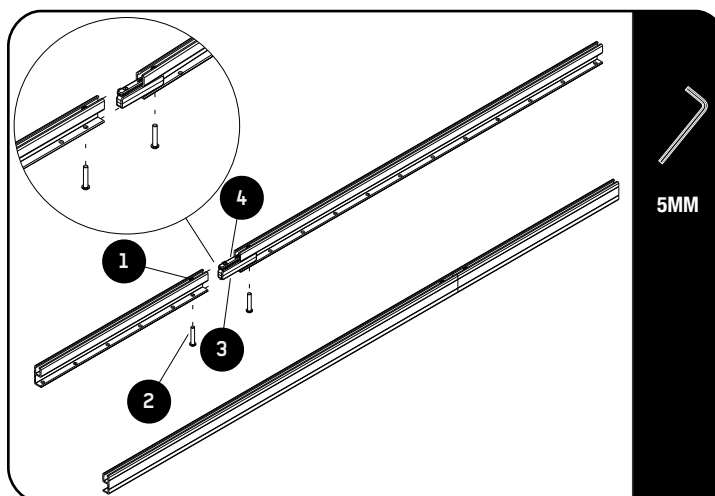


The Side Profiles are supplied in pairs. Take one profile from each pair, one short and one long (Except for the 2772mm long Slimline II rack where the Side Profiles will be equal length. Even though both pairs are the same length it is still important that you take one Side Profile from each pair).

If you look at the Side Profiles you will see that at one end there is a hole that goes through the top and bottom of the "U" Channel.

(Refer to Image 2.1). These are the Joiner Holes that you will be using.

2.2



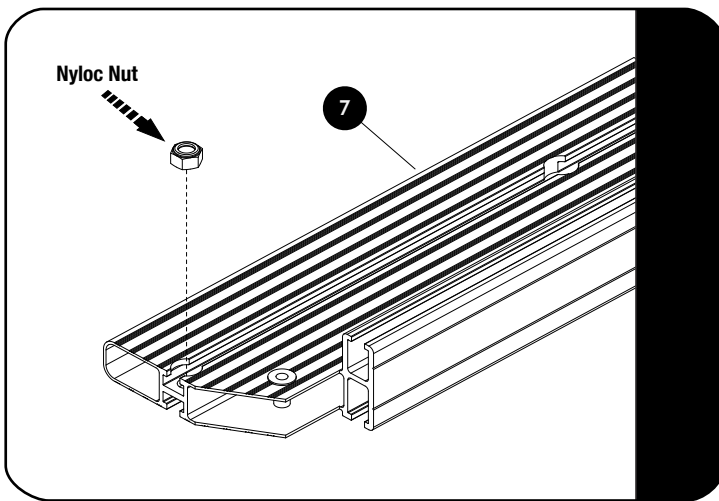
Insert a Thick Joiner (Item 3) into the "U" Channel of the Side Profile lining up the first hole with the hole in the side profile as show in 2.2.

Now grab a Thin Joiner (Item 4) and Nyloc Nut (Item 1). Slide the Joiner into the "T-slot", followed by a Nyloc Nut. The Nyloc Nut should sit on top of the Thin Joiner with the "Dome" of the Nyloc Nut facing up. Line up the outer hole of the Thin Joiner and Nyloc Nut with the Joiner Hole and loosely fasten it all together using a M8 x 45 Button Head Bolt (Item 2) and a 5mm Allen Wrench.

Slide the matching Side Profile over the two Joiner pieces, remembering to insert a Nyloc Nut, and fasten once again using a M8 x 45 Button Head Bolt. Repeat the above steps for the other side.

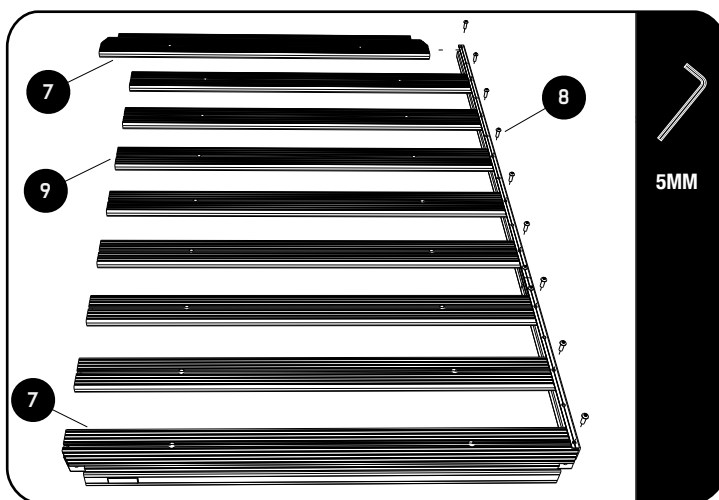
3 RACK ASSEMBLY - COMBINED SLATS AND STANDARD SLATS

3.1



Look at the Combined Slats and Standard Slats (Item 7 & 9) and ensure that there is a Nyloc Nut inserted into each machined end pocket. If the Nyloc Nut has fallen out during shipping, insert it back into the pocket as shown.

3.2



Turn the Combined Slat (Item 7) and the Side Profile Assembly upside down. Ensure that the nut in the Combined Slat is at the bottom. Push the one end of the Combined Slat into the Side Profile assembly and align the holes.

Use a M8 x 25 Button Head (Item 8) and loosely tighten using a 5mm Allen Wrench.

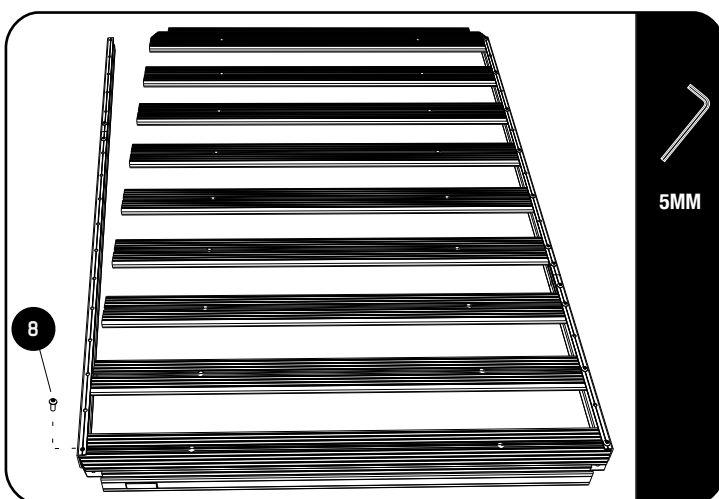
Do the same with the second Combined Slat on the other end of the Side Profile Assembly.

Take a Standard Slat (Item 9) and as with the Combined Slat, slide the one end into the Side Profile Assembly as shown. Ensure that the nut is at the bottom.

Use a M8 x 25 Button Head Bolt (Item 8) and loosely fasten the Standard Slat to the Side Profile using a 5mm Allen Wrench.

Repeat the process for the remaining Standard Slats making sure that there is an open hole in the Side Profile in between each slat.

3.3

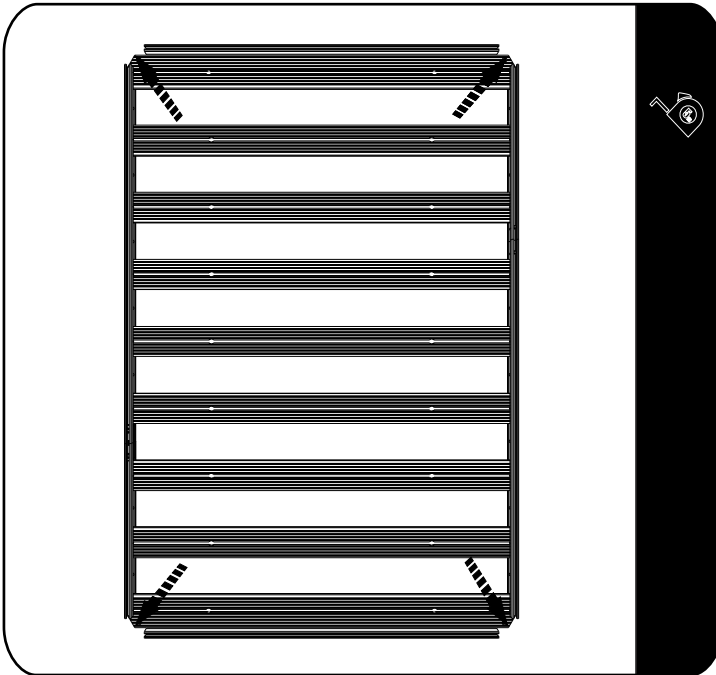


Take the other Side Profile Assembly and starting at the one end push the Side Profile over the ends of the Combined Slat and Standard Slats, aligning the holes and loosely inserting the M8 x 25 Button Heads as you work your way to the Combined Slat at the other end.

3

RACK ASSEMBLY - STANDARD SLATS

3.4



Square the Side Profiles and Slats up before fully tightening all the fasteners.

Using a tape measure, measure from the one corner across to the other corner. Do the same on the opposite corners, if the two measurements are the same the rack will be square.

Fully tighten all the M8 x 25 Button Head Bolts

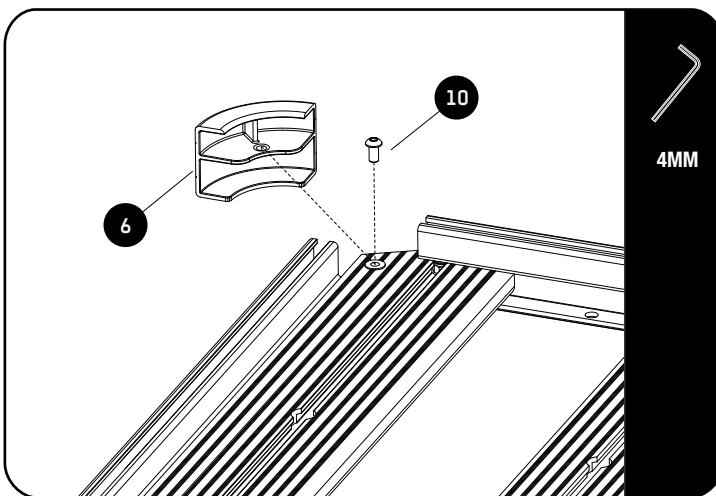


The recommended torque setting for the M8 Button Head Bolts is 20 Nm or 15 ft lb.

4

RACK ASSEMBLY- CORNERS

4.1



Flip the tray right side up.

Push the Corner into position as shown, aligning the hole in the Corner with the Rivnut already inserted in the Combined Slat. Use a M6 x 12 Button Head Bolt (Item 10) and fasten the Corner in position.

5 RACK ASSEMBLY - WIND DEFLECTOR

IN THE BOX

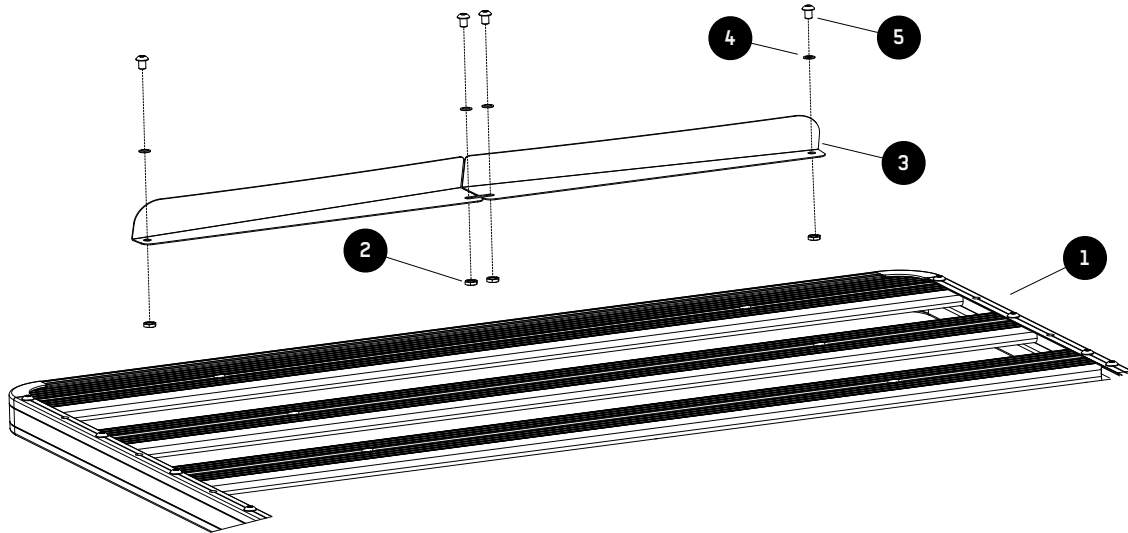
1	1	Slimline II Tray
2	4	M8 Half Nut
3	2	Wind Deflector (1LH + 1RH)
4	4	Schnorr Washer
5	4	M8 x 12 Button Head Bolt

TOOLS NEEDED



5mm

FIGURE 1.2



6**RACK ASSEMBLY - WIND DEFLECTOR**

NOTE : The Wind Deflector must be fitted to the underside of the front Combined Slat.

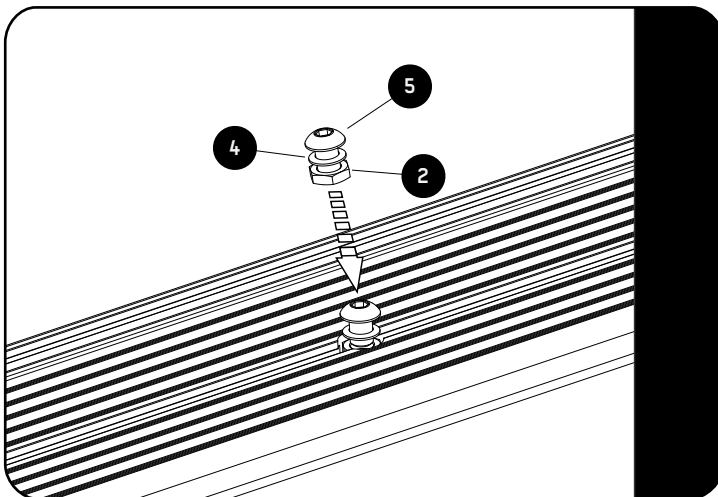
If you are going to put a Leg or Foot on the Combined Slat (Recommended), you will need to slide the M8 Bolt used for attaching these into the Machined Slots before assembling the Wind Deflector.

6.1



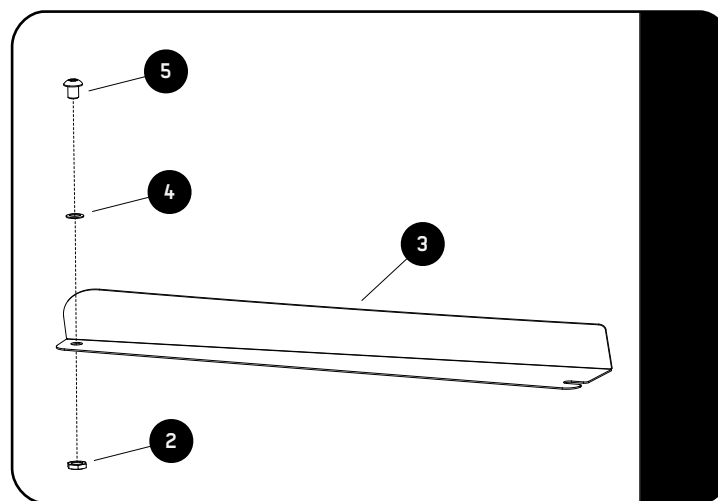
Ensure that your Slimline II Tray is upside down. Check by looking at the product sticker. It should be upside down as shown.

6.2



Insert two Button Head Bolts, M8 Half Nuts and Schnorr Washers (Items 2, 4 & 5) assemblies into the Combined Slat as shown. Slide them to the center of the Combined Slat making sure that the Schnorr Washer is above the T-slot Channel.

6.3

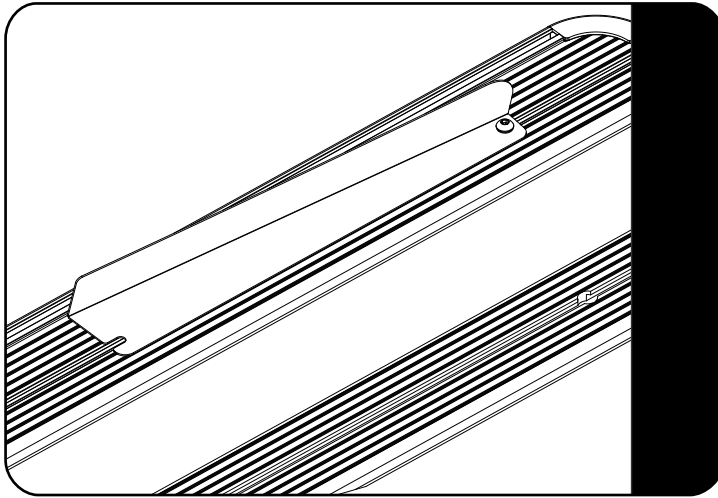


Assemble Items 2, 4 & 5 to both LH & RH Wind Deflectors (Item 3) as shown.

6

RACK ASSEMBLY - WIND DEFLECTOR

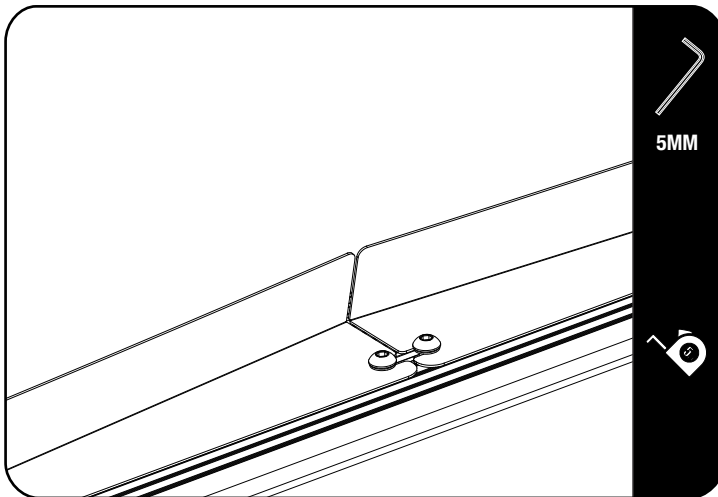
6.4



Insert the nut assembled to the Wind Deflector in the Combined Slat T-slot Pocket and slide to the side as shown in Figure 8.4.

Repeat for the other half of the Wind Deflector.

6.5



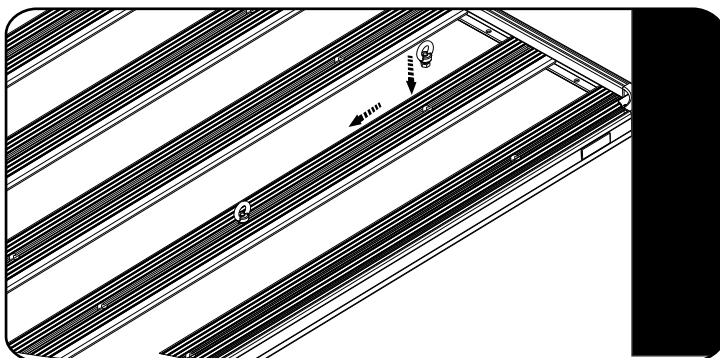
Center the Wind Deflector on the rack and move the bolt assemblies from Figure 8.2 into the slots as shown in Figure 8.5.



NOTE : Once the rack is fitted to the vehicle, take it for a test drive. Should there be excessive wind noise try moving the two Wind Deflectors slightly apart, leaving a gap of about 20 - 30mm.



USEFULL TIP - PRE-LOAD TIE DOWN RINGS



It is usefull to fit Tie-Down Rings (RRAC012) to your Front Runner Rack for future use before you fit any accessories.

Insert the Tie Down Rings into the machined slots and position them in the center of the rack.

7

CHECK YOUR VEHICLE INSTALLATION GUIDE

7.1

Now that your Slimline II Tray is assembled, get your Rack Kit Installation Guide out and follow the instructions to fit the Slimline II Tray to your specific vehicle.

8

HOW TO CARE FOR YOUR FRONT RUNNER GEAR

FRONT RUNNER RACKS AND ACCESSORIES ARE HAPPIEST COVERED IN MUD

But in order to maintain full functionality of the rack slots and any moving parts, you may want to give your gear a bath now and again.

It's easy! Take care of your Front Runner gear the same way you do the exterior of your vehicle:

Rinse with clean water and wipe down with a soft dry cloth. For stubborn spots, use a soft brush and mild soap.

If you really want to baby your gear, feel free to lightly wax the surfaces or use a protective spray with UV inhibitors. Just be sure not to use compound waxes that contain abrasives.

In salty coastal climates, or snowy regions where salt is used to clear roadways, applying a silicone based oil or spray to nuts and bolts will help prevent corrosion.

WHETHER YOU LIKE TO ROLL DIRTY OR CLEAN, YOUR FRONT RUNNER GEAR WILL GIVE YOU MANY YEARS OF SERVICE!

9

INSTALL OTHER VEHICLE AND RACK ACCESSORIES

Now's the time to visit your favorite Front Runner Dealer in person or online.



INSTALL TIME: 2.5 Hours

READ ME FIRST:

Thank you for purchasing a Front Runner Slimline II Load Bed Rack or Load Bar Kit.



Your Kit will contain the following items:

- 1.) A Slimline II Tray or Load Bar Set
- 2.) Universal Load Bed Tracks
- 3.) Universal Load Bed Legs

The different sections in this document will help you fit the various items received in your kit.

Section 1: Fitment of Load Bed Tracks to your vehicle.

Section 2: Fitment of Universal Load Bay Legs & Slimline II Tray.

Section 3: Fitment of Universal Load Bay Legs & Load Bars.

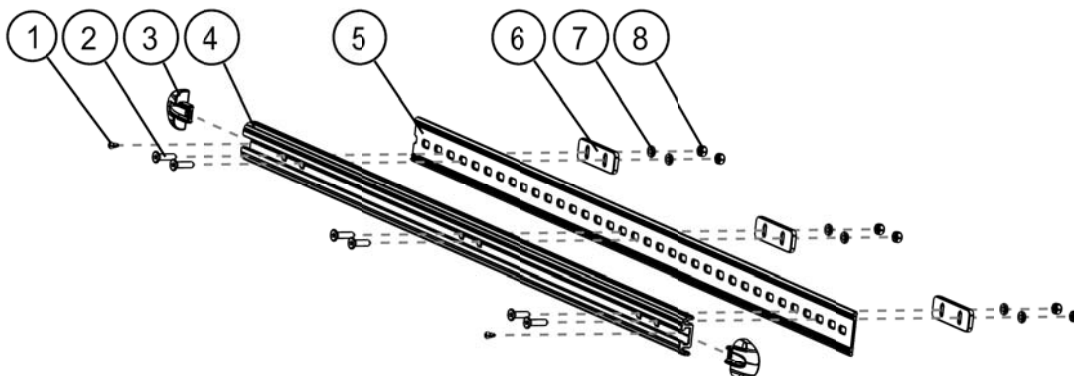
1 INSTALL LOAD BED TRACKS

- (**A**) Here is what you are looking at for TBRU002. Please note that only one side's components are shown below. Familiarize yourself with the parts and then step away from the work area and read through these instructions from beginning to end. Take a moment as a little prep now may save you a lot of time later.

Item #	Quantity	Description
1	4	M3 x 6 SELF TAPPING SCREW
2	12	M6 x 25 COUNTERSUNK BOLT
3	4	END CAP
4	2	LOAD BED TRACK
5	2	RUBBER TRACK LINER
6	6	CLAMP PLATE
7	12	M6 FLAT WASHER
8	12	M6 NYLOC NUT

You will need:

- | | |
|---|---|
| <input type="checkbox"/> 4 mm Hex key | <input type="checkbox"/> Marking pen |
| <input type="checkbox"/> 10 mm Wrench | <input type="checkbox"/> Measuring tape |
| <input type="checkbox"/> 4 & 7 mm Drill bit | <input type="checkbox"/> Small Phillips Screwdriver |
| <input type="checkbox"/> Drill machine | <input type="checkbox"/> Friend |

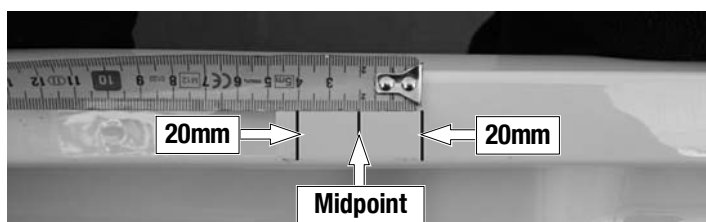


1 INSTALL LOAD BED TRACKS

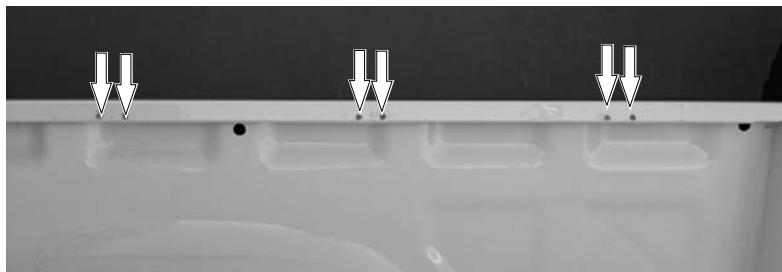
- (B) Looking inside the load bin of the vehicle, measure the length of the load bin from the back of the cabin below the rear window to the start of the tail gate. Using a marking pen, mark the midpoint.



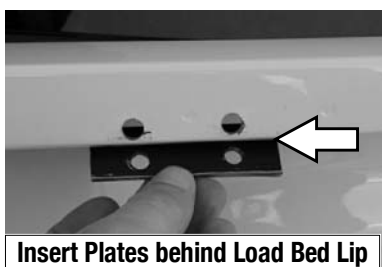
- (C) Make another two markings, 20 mm either side of your center marking from Step 2B.



- (D) Position the Track (Item 4) against the side wall of the load bin, lining up the two center holes in the Track with the two 20 mm markings from Step 2C. Ensure that the Track is sitting flush with the top of the load bin. Mark the position of all 6 holes onto the Load Bin. Remove the Track and drill 4 mm pilot holes on all your markings. Change drill bits and re drill all the holes to 7 mm.



- (E) Ensuring that the Rubber Track Liner (Item 5) is fitted to the Tracks, reposition each Track lining up the holes in the Track with the holes from Step 2D. Insert the M6 x 25 Countersunk Bolts (Item 2). Place the Clamp Plates (Item 6) behind the lip on the load bed and over the ends of the Countersunk Bolts. Secure the Clamp Plate and Track in position using the M6 Flat Washers and M6 Nyloc Nuts (Items 7, 8).



2 INSTALLATION OF SLIMLINE II TRAY



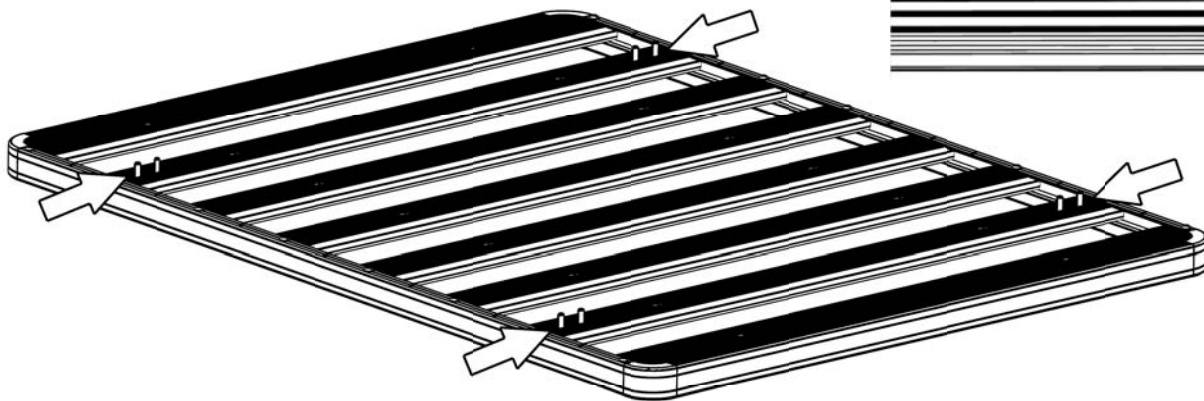
Note: If you have not fitted the Universal Load Bed Legs, fit them according to the Universal Load Bed Leg Fitting Instruction - Document LASS026.

If your Slimline II Tray is not already assembled, assemble it as per the Slimline II Tray Universal Assembly Instruction - Document RRTUNI.

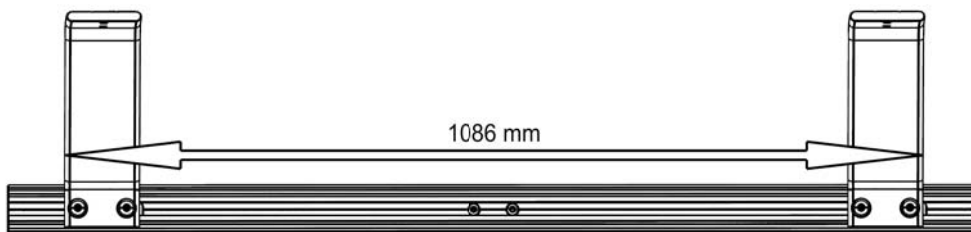
You will need:

- 13 mm Flat or Socket Wrench
- Measuring tape
- Friend

- (**A**) With your Rack in the upside down position (Product Sticker should be upside down) slide two M8 x 25 Hex Bolts supplied with the Universal Load Bed Legs into the end of each Slat as indicated by the arrows using the machined Slots as shown.

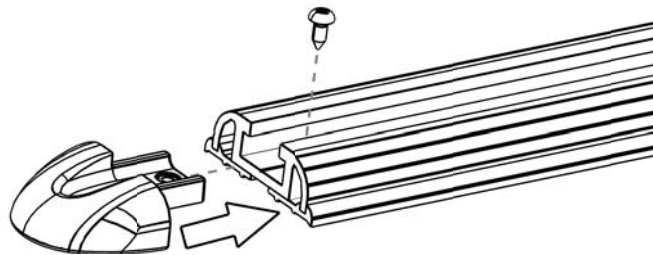


- (**B**) Space the two Leg Assemblies evenly either side of Midpoint of the Track so that they are spaced 1086 mm apart - outside to outside as shown below. Loosely tighten the bolts securing the Legs to the Track.



2 INSTALLATION OF SLIMLINE II TRAY CONT...

- (C) Slide an End Cap (Item 3) into the ends of Track and secure in position using the M3 x 6 Self Tapping Screw (Item 1).

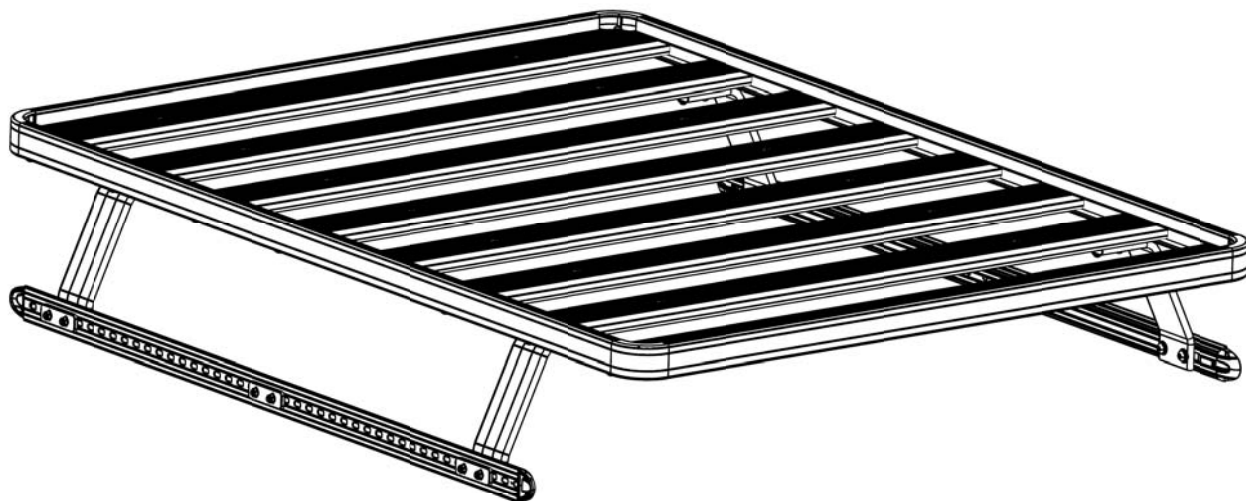


- (D) Grab your friend and with one of you on each side of the Rack, flip it end over end so that the bolts are facing down. Approach the vehicle from the rear lifting the Rack above the Legs. Slowly lower the Rack lining up the bolts in the Rack with the holes in the Legs. You may need to adjust the position of the Legs.

Position the Rack front to back and fasten the bolts securing the Legs to the Tracks (From Step 2B).

Place the M8 Flat Washers and M8 Nyloc Nuts supplied with the Universal Load Bed Legs onto the Bolts securing the Rack to the Legs and hand tighten. Center the Rack Left to Right. Apply weight/downward pressure to the Rack so that the Slats are sitting flush onto the Legs and fasten the M8 Nyloc Nuts securing the Rack to the Legs. Place a M8 Nut Cap supplied with the Universal Load Bed Legs over each of the M8 Nyloc Nuts.

Congratulations, you have completed your installation. Take a step back and admire your work. Good Job!

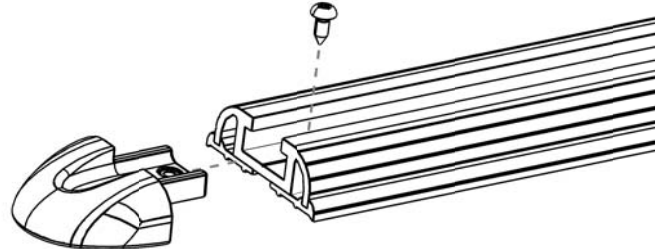


3 INSTALLATION OF LOAD BARS

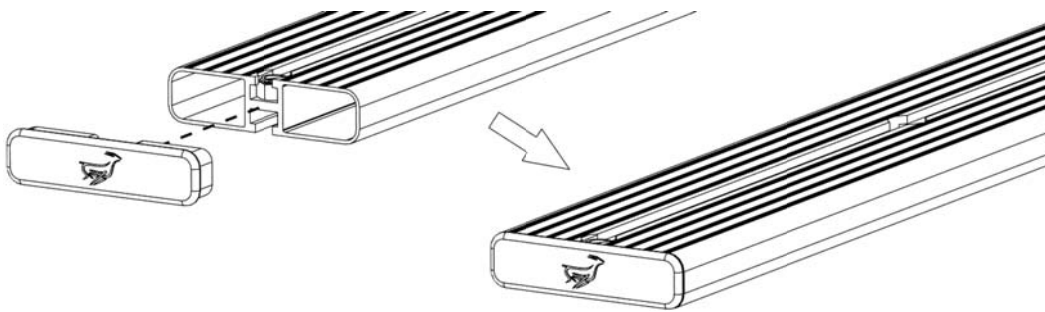


Note: If you have not fitted the Universal Load Bed Tracks or Legs, please fit them as per the Universal Load Bed Track and Universal Load Bed Leg Fitting Instructions (Documents TRBU001 & LASS026).

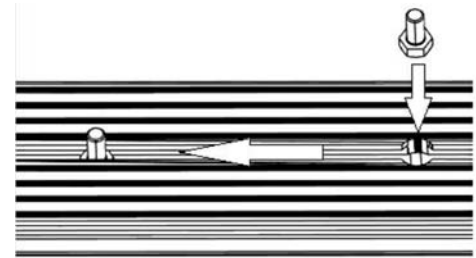
- (A) Slide an End Cap (Item 3) into the ends of Track and secure in position using the M3 x 6 Self Tapping Screw (Item 1).



- (B) Fit a Plastic End Caps received with your Load Bars into each end of the Load Bars as shown.



- (C) With the Load Bars in the upside down position (Check using the Buck Logo on End Caps from Step 2B as an indicator), slide two M8 x 25 Hex Bolts supplied with the Universal Load Bed Legs into each end of the Load Bars using the machined slots as shown.



3 INSTALLATION OF LOAD BARS CONT...

- (**D**) Position the Load Bay Legs as required and secure in position. Turn the Load Bars over so that the Bolts inserted in Step 2B are facing down. Lower the Load Bars onto the Legs, lining up the bolts in the Load Bars with the holes in the Legs. You may need to adjust the position of the Bolts.

Place the M8 Flat Washers and M8 Nyloc Nuts supplied with the Universal Load Bed Legs onto the Bolts securing the Load Bars to the Legs and hand tighten. Center the Load Bars Left to Right. Apply weight/downward pressure to the Load Bars so that they are sitting flush onto the Legs and fasten the M8 Nyloc Nuts securing the Rack to the Legs. Place a M8 Nut Cap supplied with the Universal Load Bed Legs over each of the M8 Nyloc Nuts.

Congratulations, you have completed your installation. Take a step back and admire your work. Good Job!



4 INSTALL OTHER VEHICLE AND RACK ACCESSORIES

- (**A**) Now's the time to visit your favorite Front Runner dealer in person or online.

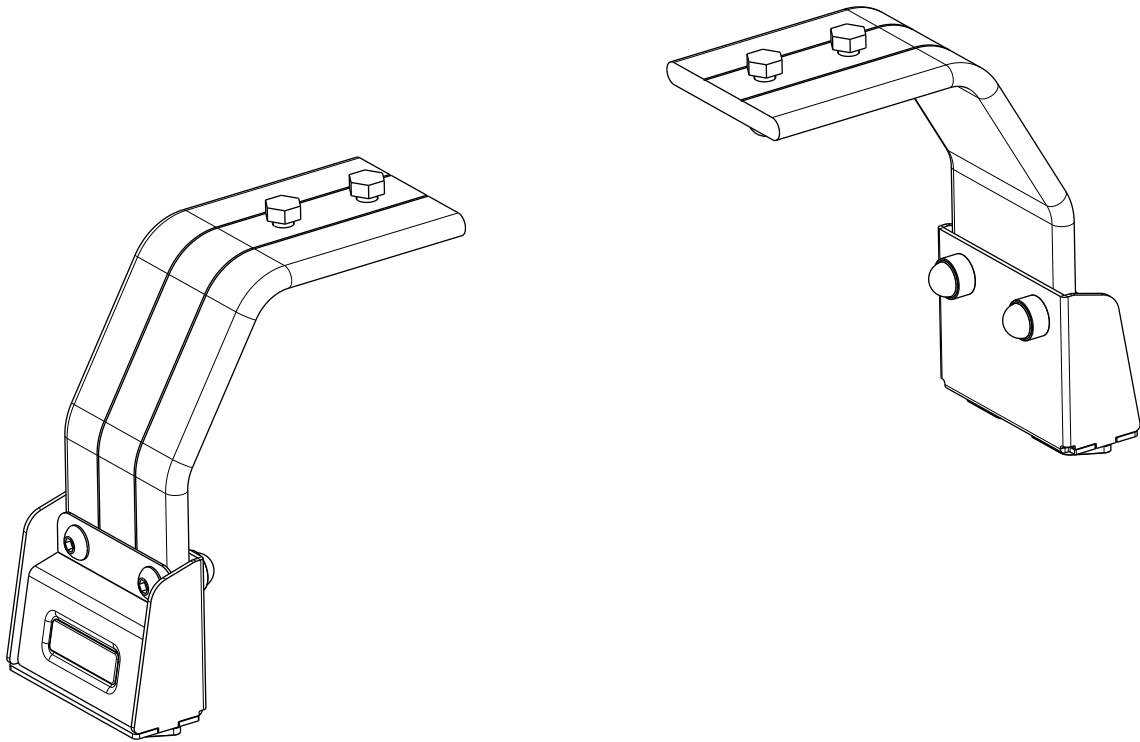


FRONT RUNNER
VEHICLE OUTFITTERS

PICK-UP ROLL TOP LEG MOUNT

ENG

LASS028



READ ME !

Thank you for purchasing a Front Runner Pick-Up Roll Top Leg Mount.

Before you start, take a moment to familiarize yourself with the Fitting Instructions and the components received.

Refer to Page 2 for a list of all the components, quantities and tools required.

IMPORTANT WARNING!

IT IS CRITICAL THAT ALL FRONT RUNNER PRODUCTS BE PROPERLY AND SECURELY ASSEMBLED AND ATTACHED TO YOUR VEHICLE. IMPROPER ATTACHMENT COULD RESULT IN AN AUTOMOBILE ACCIDENT, AND COULD CAUSE SERIOUS BODILY INJURY OR DEATH. YOU ARE RESPONSIBLE FOR ASSEMBLING AND SECURING ALL FRONT RUNNER PRODUCTS TO YOUR VEHICLE, CHECKING THE ATTACHMENTS PRIOR TO USE, AND PERIODICALLY INSPECTING THE PRODUCTS FOR ADJUSTMENT, WEAR AND DAMAGE. THEREFORE, YOU MUST READ AND UNDERSTAND ALL OF THE INSTRUCTIONS AND PRECAUTIONS SUPPLIED WITH YOUR FRONT RUNNER PRODUCT PRIOR TO INSTALLATION OR USE. IF YOU DO NOT UNDERSTAND ALL OF THE INSTRUCTIONS AND CAUTIONS, OR IF YOU HAVE NO MECHANICAL EXPERIENCE AND ARE NOT THOROUGHLY FAMILIAR WITH THE INSTALLATION PROCEDURES, YOU SHOULD HAVE THE PRODUCT INSTALLED BY A PROFESSIONAL INSTALLER OR OTHER QUALIFIED PERSONNEL.

NOTE: Front Runner will not be responsible for any damage caused by the failure to install the product according to these instructions.

Please call us if you have any questions about the installation of this product.

1

GET ORGANIZED

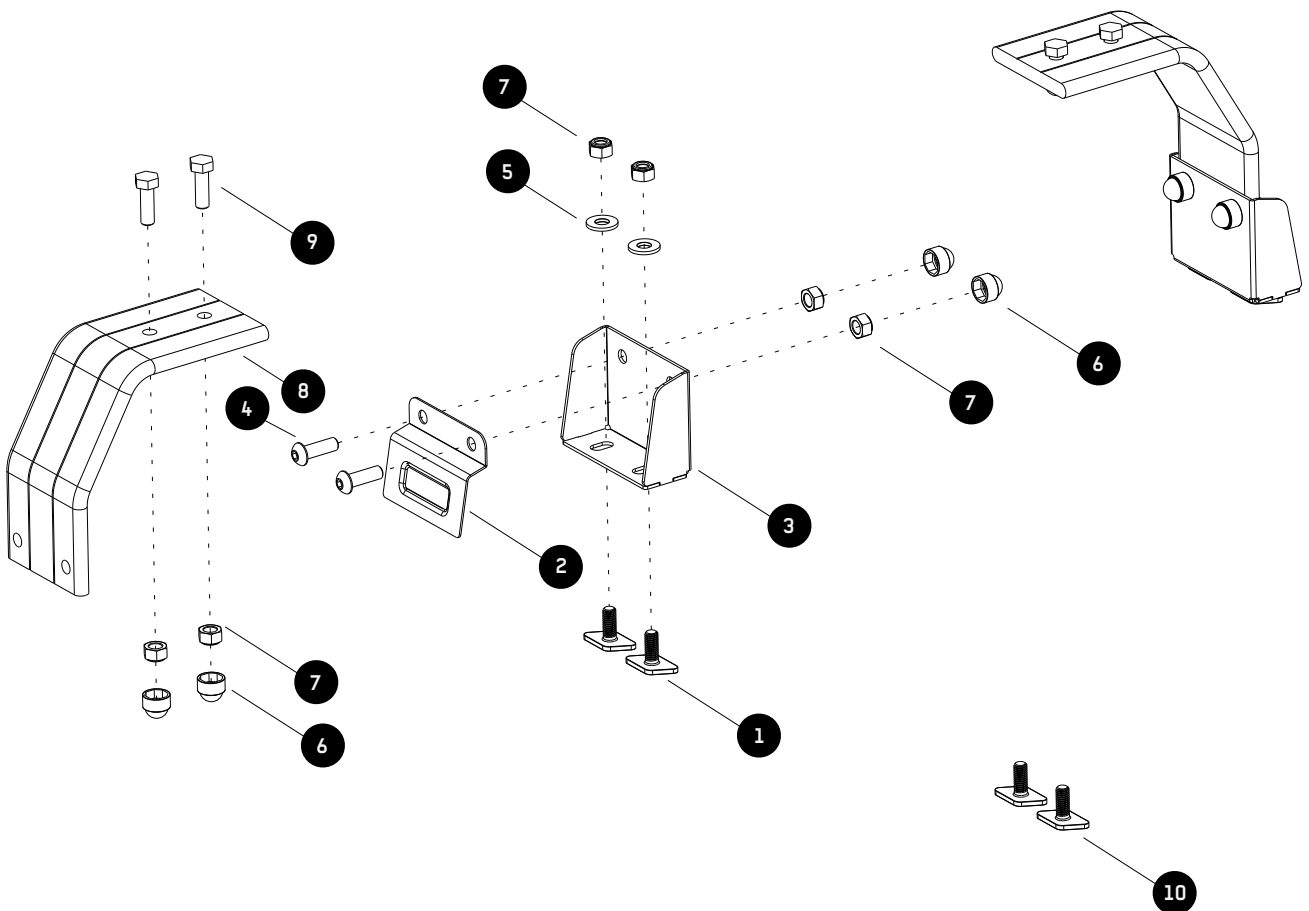
IN THE BOX

1	4 X	M8 x 20 T-Bolt - 18mm Wide
2	2 X	Cover Plates
3	2 X	Leg Mount
4	4 X	M8 x 25 Button Head
5	4 X	M8 x 19 x 2SS Flat Washer
6	8 X	M8 Nut Cap
7	12 X	M8 Nyloc Nut
8	2 X	Leg
9	4 X	M8 x 25 Hex Bolt
10	4 X	M8 x 20 T-Bolt - 13mm Wide

TOOLS NEEDED

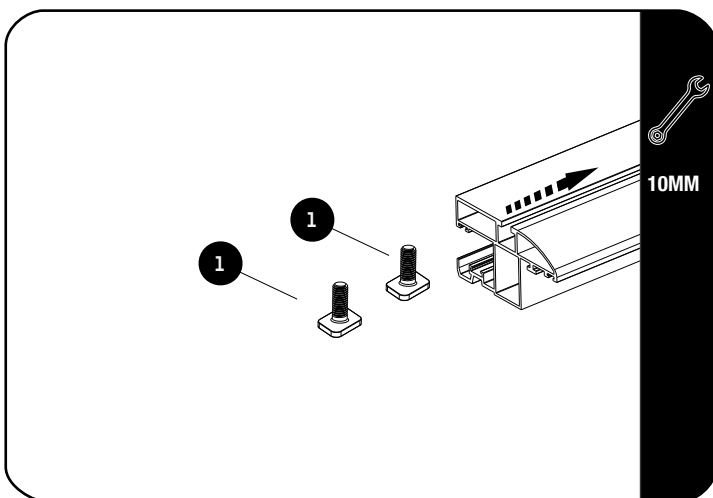


FIGURE 1.1



2 FIT AND SECURE

2.1



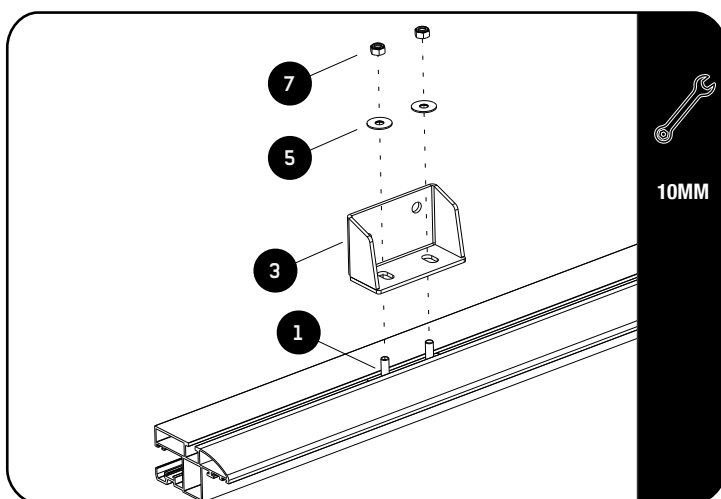
Slide four M8 x 20 T-Bolts (Item 1) into each side profile.

(Four are needed per side to fit Load Bars or a Rack).



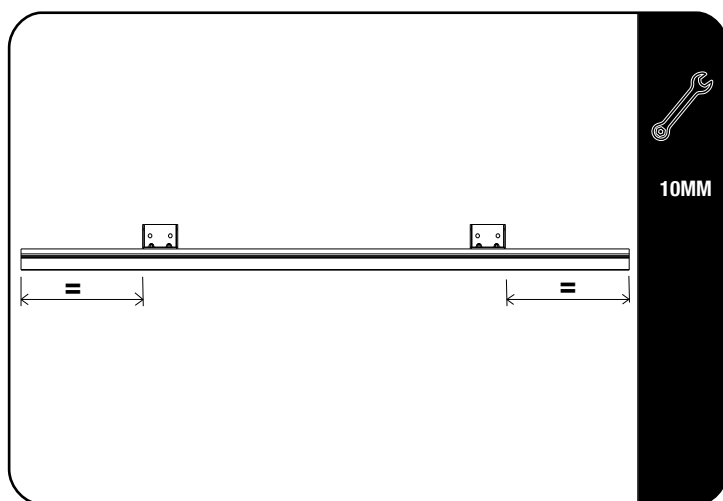
Depending on your track you might need the 13mm T-Bolt (Item 10).

2.2



Loosely fit a Leg Mount (Item 3) to each of T-Bolts using M8 x 19 x 2 Flat Washers and M8 Nyloc Nuts (Items 5 & 7).

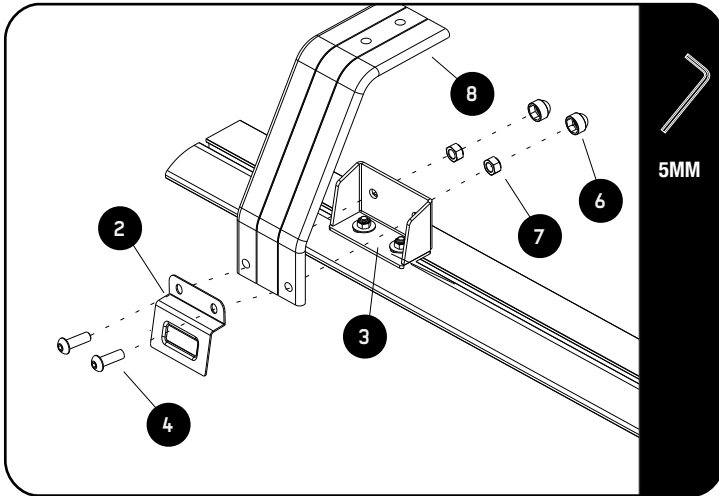
2.3



Looking from the side of the vehicle, position the Leg Mounts (Item 3) to center the Slimline II Rack or place Load Bars where desired over the load bed.

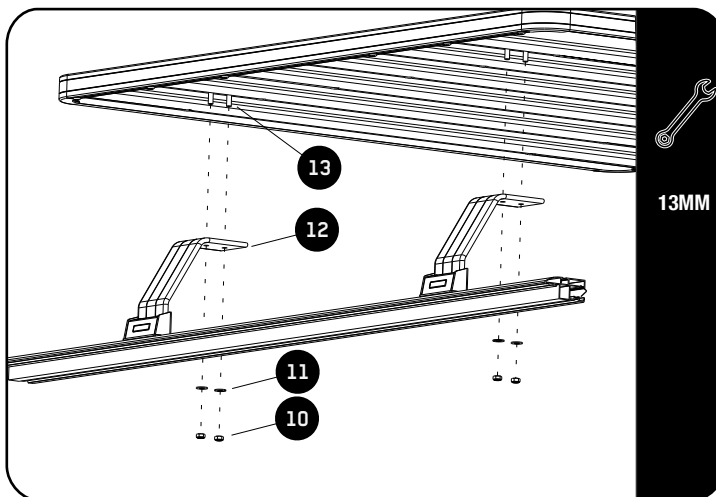
2**FIT AND SECURE**

2.4



Assemble the Legs (Item 8) to the Leg Mount (Item 3) by using M8 x 25 Button Heads and M8 nyloc Nuts (Items 4 & 7) and the M8 x 20 T-Bolts (Items 1).

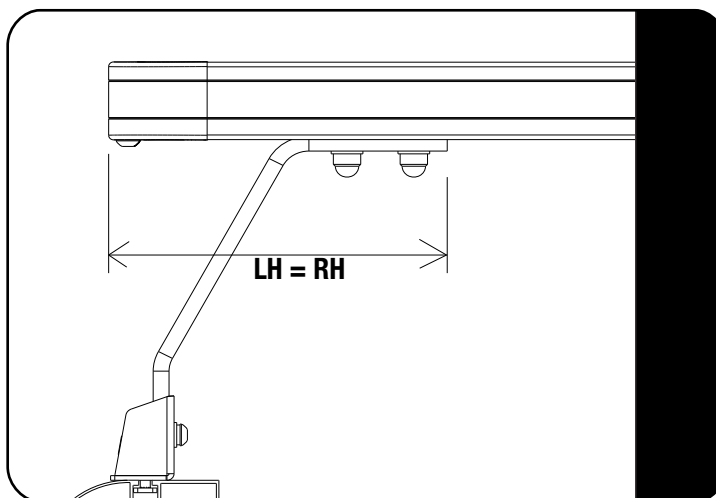
2.5



Loosely fit your Slimline II Rack by using M8 x 25 Hex Bolts, M8 x 16 x 1.6SS Flat Washers and M8 Nylocs (Items 10, 11, 13) as shown.

You can use the same method for Load Bars.

2.6



Center the rack on the Legs before fully tightening (LH = RH).

Finish of by placing M8 Nut Caps (Item 9) over all M8 Nyloc Nuts.

Use the same method for Load Bars.

3

FINISH

Congratulations! You did it. Take a step back and admire your work!

4

INSTALL OTHER VEHICLE AND RACK ACCESSORIES

Now's the time to visit your favorite Front Runner Dealer in person or online.

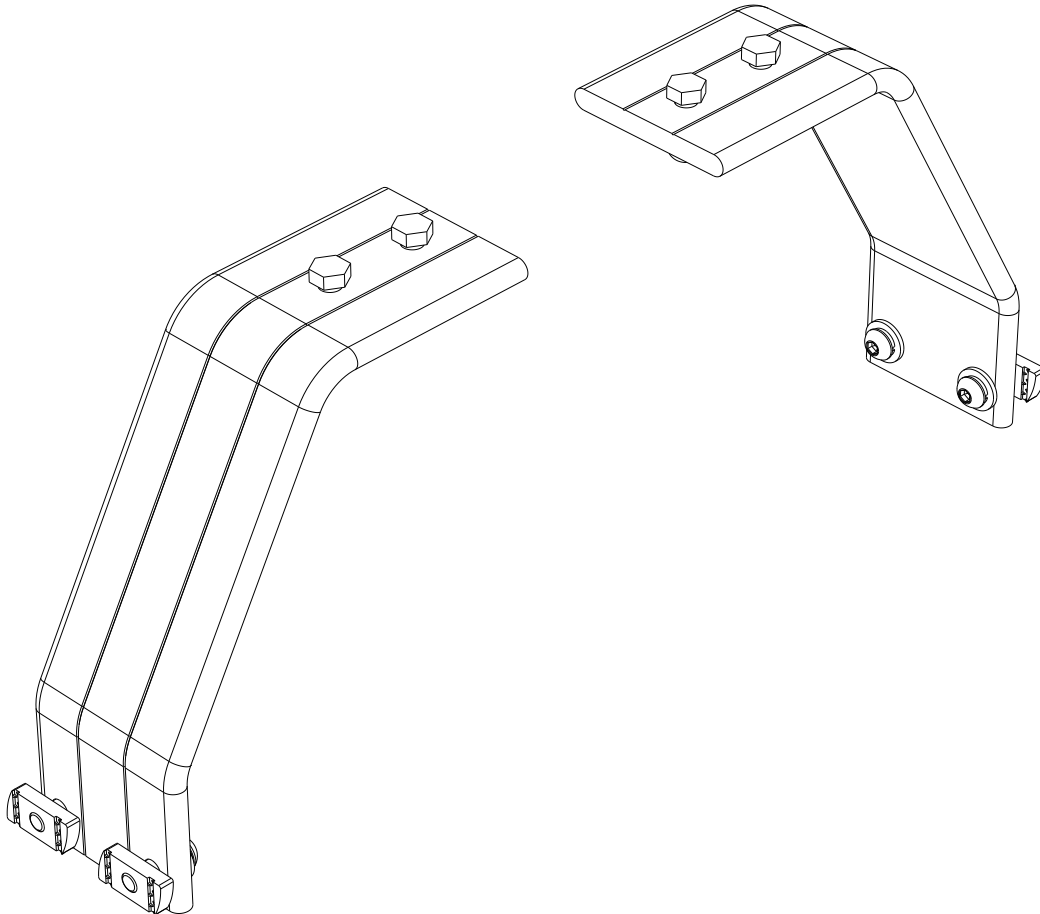


FRONT RUNNER
VEHICLE OUTFITTERS

UNIVERSAL LOAD BED LEGS 188MM (PAIR)

ENG

LASS026



READ ME !

Thank you for purchasing a Front Runner Universal Load Bed Legs.

Before you start, take a moment to familiarize yourself with the Fitting Instructions and the components received.

Refer to Page 2 for a list of all the components, quantities and tools required.

IMPORTANT WARNING!

IT IS CRITICAL THAT ALL FRONT RUNNER PRODUCTS BE PROPERLY AND SECURELY ASSEMBLED AND ATTACHED TO YOUR VEHICLE. IMPROPER ATTACHMENT COULD RESULT IN AN AUTOMOBILE ACCIDENT, AND COULD CAUSE SERIOUS BODILY INJURY OR DEATH. YOU ARE RESPONSIBLE FOR ASSEMBLING AND SECURING ALL FRONT RUNNER PRODUCTS TO YOUR VEHICLE, CHECKING THE ATTACHMENTS PRIOR TO USE, AND PERIODICALLY INSPECTING THE PRODUCTS FOR ADJUSTMENT, WEAR AND DAMAGE. THEREFORE, YOU MUST READ AND UNDERSTAND ALL OF THE INSTRUCTIONS AND PRECAUTIONS SUPPLIED WITH YOUR FRONT RUNNER PRODUCT PRIOR TO INSTALLATION OR USE. IF YOU DO NOT UNDERSTAND ALL OF THE INSTRUCTIONS AND CAUTIONS, OR IF YOU HAVE NO MECHANICAL EXPERIENCE AND ARE NOT THOROUGHLY FAMILIAR WITH THE INSTALLATION PROCEDURES, YOU SHOULD HAVE THE PRODUCT INSTALLED BY A PROFESSIONAL INSTALLER OR OTHER QUALIFIED PERSONNEL.

NOTE: Front Runner will not be responsible for any damage caused by the failure to install the product according to these instructions.

Please call us if you have any questions about the installation of this product.

1

GET ORGANIZED

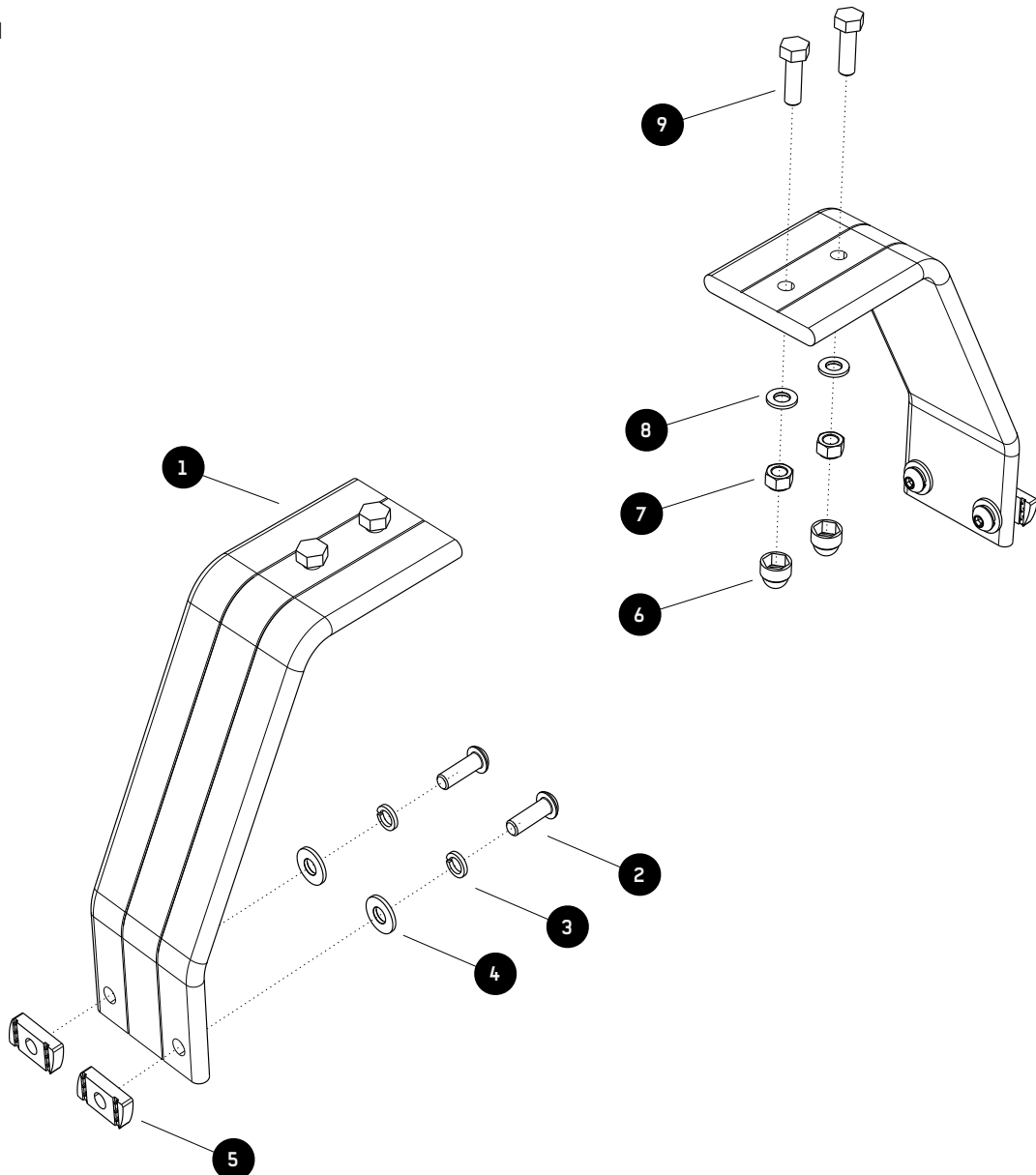
IN THE BOX

1	2 X	Leg
2	4 X	M8 x 25 Button Head Bolt
3	4 X	M8 Spring Washer
4	4 X	M8 x 19 x 2SS Flat Washer
5	4 X	M8 Channel Nut
6	4 X	M8 Nut Cap
7	4 X	M8 Nyloc Nut
8	4 X	M8 x 16 x 1.6SS Flat Washer
9	4 X	M8 x 25 Hex Bolt

TOOLS NEEDED



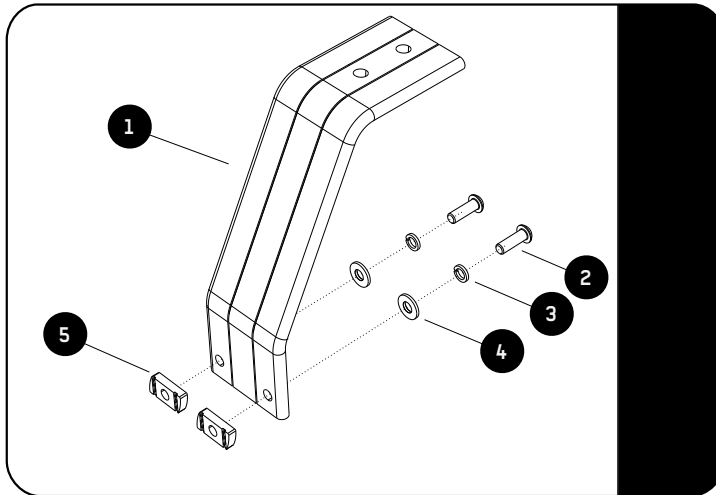
FIGURE 1.1



2

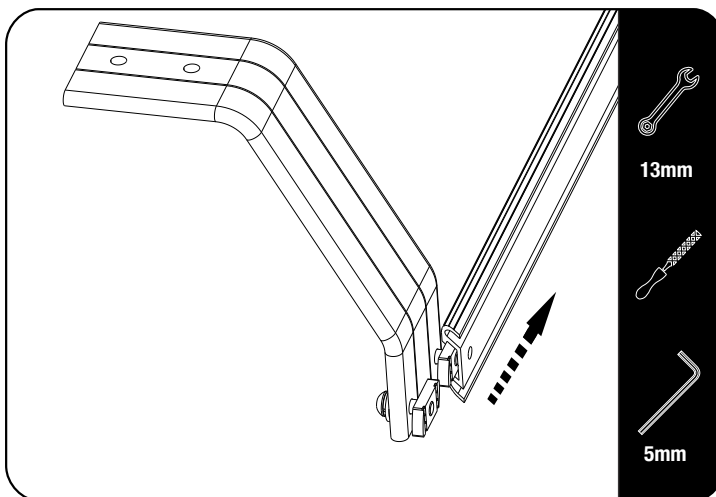
FIT AND SECURE

2.1



Loosely assemble the M8 Channel Nuts (Item 5) to the Legs (Item 1) using M8 x 25 Button Head Bolts, M8 Spring Washers and M8 x 25 x 2SS Flat Washers (Items 2, 3 & 4) as shown.

2.2



Slide the required number of Leg Assemblies into the Universal Load Bed Track as shown.

In some cases the Channel Nut may need dressing with a file to remove high spots and to insure it slides smoothly in the track.

The M8 Channel Nut will rotate at an angle in the Track when fastening.

The remaining fasteners will be used when mounting your Load Bars or Tray to the Universal Load Bed Legs.

3

FINISH

Congratulations! You did it. Take a step back and admire your work!

4

INSTALL OTHER VEHICLE AND RACK ACCESSORIES

Now's the time to visit your favorite Front Runner Dealer in person or online.