

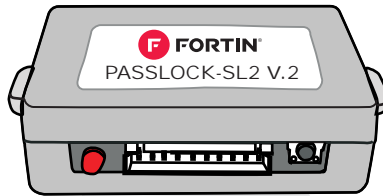

# PASSLOCK-SL2. v.2

**BYPASS MODULE FOR PASSLOCK I AND PASSLOCK II, SATURN, HUMMER H2, VATS AND NEW GENERATION**  
**MODULE DE CONTOURNEMENT PASSLOCK I, PASSLOCK II, SATURN, HUMMER H2, VATS ET NEW GENERATION**



See wiring schematic configuration

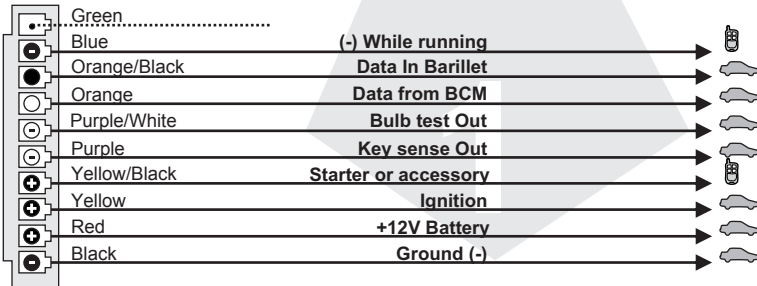

● INPUT |

○ OUTPUT |

Connect wire to vehicle



Connect wire to Remote-Starter/Alarm

## Make the connections of the PASSLOCK-SL2. v.2:

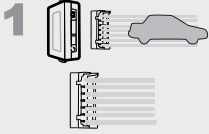

### Connector 1 (White):

- (I) Locate the wiring type for the vehicle on the VEHICLE FIT GUIDE (P.2)
- (II) Make the connections associated with the vehicle in the WIRING SCHEMATIC CONFIGURATION (P.2-3)

## VEHICLE FIT GUIDE

Vehicles	Years	Schematic #	Vehicles	Years	Schematic #	Vehicles	Years	Schematic #
<b>Buick</b>			<b>Chevrolet</b>			<b>Oldsmobile</b>		
Century	1997-2005	1	Corvette	1989-2004	1	Hombre	1998-2000	4
LeSabre	1993-1999	1	Equinox	2005-2006	5	I-280	2005-2006	6
Park Avenue	1991-1996	1	Express Van	1998-2007	4	I-290	2007-2008	6
Rainier	2004-2007	4	Impala	2000-2005	4	I-350	2005-2006	6
Reatta	1998-1996	1	Lumina	1995-2000	1	I-370	2007-2008	6
Regal	1996-2004	1	Malibu	1997-2003	4	<b>Pontiac</b>		
Riviera	1994-1999	1	Monte Carlo	1995-1999	1	Achieva	1996-1998	2
Roadmaster	1995-1996	1		2000-2006	4	Alero	1999-2004	3
Skylark	1996-1998	2	S10 - S15	1998-2004	4	Aurora	1995-1999	1
<b>Cadillac</b>			Silverado1500	2000-2007	4	Bravada	1998-2004	3
Allante	1991-1993	1	Silverado2500	2000-2007	4	Cutlass	1994-1999	1
Brougham	1990-1992	1	SSR	2004-2006	4	Eighty-Eight	1995-1999	1
DeVille	1989-1999	1	Suburban	1998-2007	4	Intrigue	1997-2001	3
Eldorado	1988-2002	1	Tahoe	1997-2006	4	LSS	1997-1999	1
Escalade	1999-2006	4	TrailBlazer	2002-2009	4	Nighty-Eight	1995-1996	1
Fleetwood	1990-1996	1	<b>GMC</b>			Regency	1997-1998	1
Seville	1991	1	Canyon	2004-2008	6	<b>Pontiac</b>		
Seville SLS	1992-1997	1	Envoy	1998-2009	4	Bonneville	1992-1999	1
Seville STS	1992-1997	1	Jimmy	1998-2005	4	Firebird	1993-2002	1
<b>Chevrolet</b>			Safari	1998-2005	3	Grand Am	1995-1998	2
Astro	1998-2005	4	Savana	1998-2007	4		1999-2005	4
Avalanche	2002-2006	4	Sierra	1999-2007	4	Grand Prix	1994-1996	1
Blazer	1998-2005	4	Sonoma	1998-2004	4	G5 - Pursuit*	2005-2006	6
Camaro	1993-2002	1	Suburban	1998-1999	4	Sunfire	1995-1999	2
Caprice	1994-1996	1	Yukon	1998-2006	4		2000-2005	4
Cavalier	1995-1999	2	<b>Hummer</b>			Torrent	2006	5
	2000-2005	4	H2	2003-2007	4	<b>Saturn</b>		
Cobalt*	2005	6	H3	2005-2009	6	Ion	2003-2007	6
Colorado	2004-2013	6	H3T	2009	6	S Series	2000-2002	4
			<b>Isuzu</b>			L Series	2000-2005	4
			Ascender	2003-2008	4	Vue	2002-2007	5

\* Vehicle's with a + stamped on the key are not supported.

## Wiring Schematic Configuration

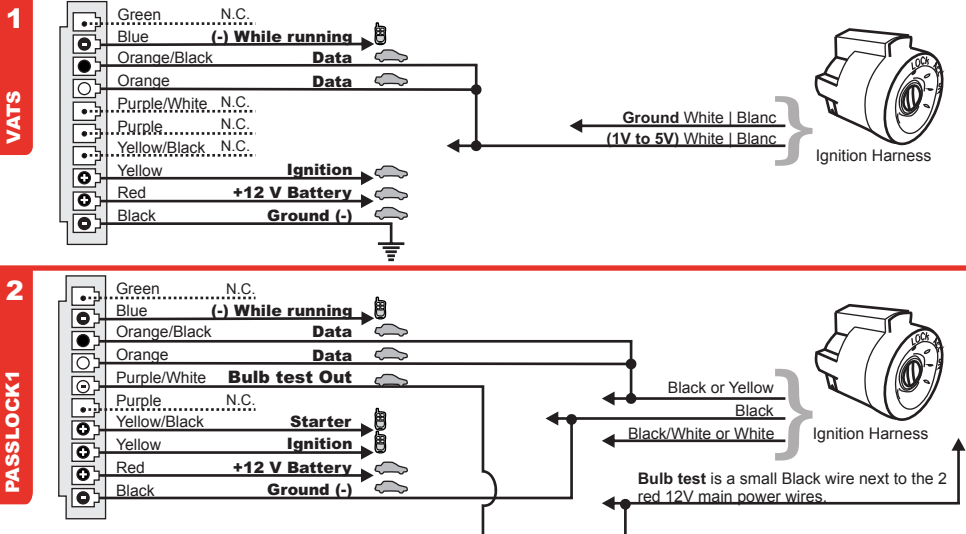

**3**  
PASSLOCK 2A

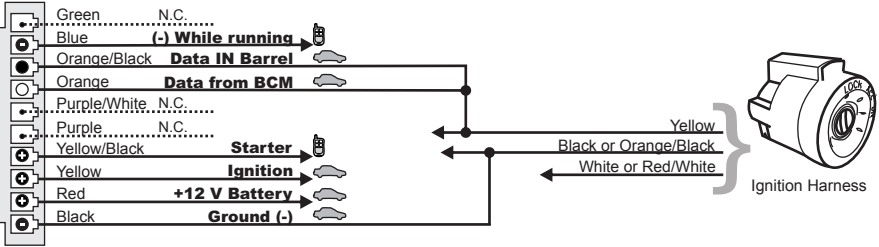

**4**  
PASSLOCK 2B

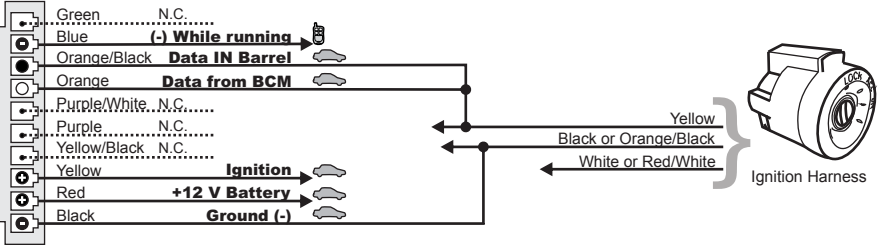

**5**  
PASSLOCK 2C

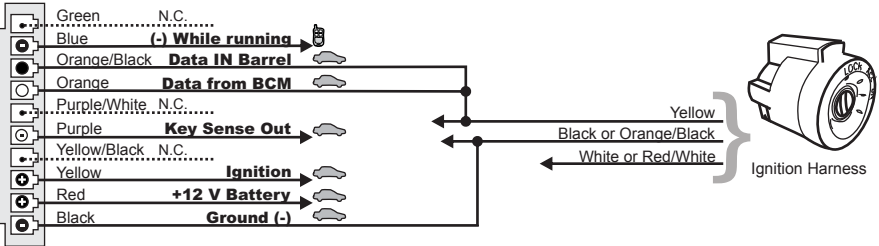

**6**  
NEW GENERATION 6

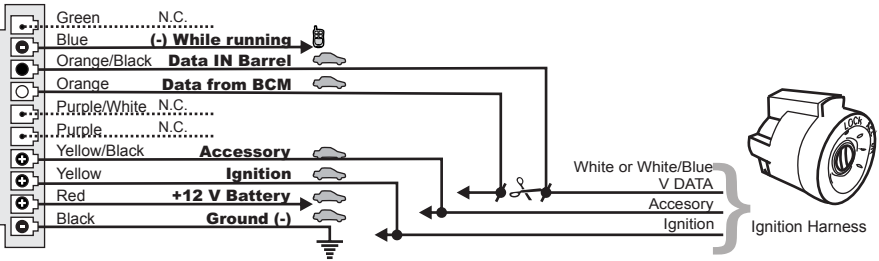

○ OUTPUT

Connect wire to vehicle

● INPUT

Connect wire to Remote-Started/Alarm

## INSTRUCTIONS

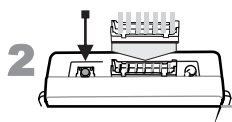

**Press** and hold the programming button.  
**Plug** the connector into the PASSLOCK-SL2. v.2 interface.

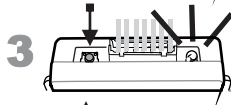

*The LED will turn on, indicating the beginning of programming.*

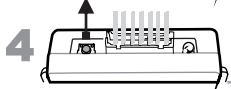

**Release** the programming button.



**Turn** the key to the ignition position.

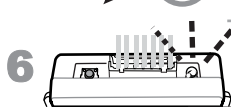

*The LED will flash rapidly.*



**You have 4 seconds to:**



**Start** the vehicle with the key.

If this step is not performed within 4 seconds disconnect the connector and go to step 2.

**8**

The LED will flash X times

Number of Flashes	Wiring schematic #
x 3	1, 4 or 5
x 1	2
x 2	3
x 4	6

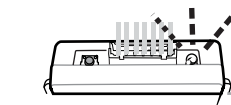

**Turn** the key OFF.  
 The PASSLOCK-SL2. v.2 is programmed.