



## PROPERLY SELECTING ELECTRONIC FUEL INJECTION COMPONENTS

One of the more commonly misunderstood aspects of Electronic Fuel Injection (EFI) is how to select the correct size fuel injectors, fuel pump and Mass Air Flow (MAF) sensor for a particular engine horsepower output. The following information is intended to offer a very brief tutorial on properly selecting the most common EFI components.

### FUEL INJECTORS

First and foremost, adding larger fuel injectors alone will NOT create extra horsepower! The purchase of larger fuel injectors should only be considered when your engine has exceeded the horsepower capacity of the existing fuel injectors, at which point larger injectors are then required to SUPPORT the additional horsepower. If you add larger-than-stock injectors to an otherwise stock engine, you should not expect any horsepower increase whatsoever.



The nominal injection pressure for most Ford EFI systems is 39.15psi (270kPa) “across the injector.” The term “across the injector” takes manifold pressure and fuel rail pressure into account, and is usually referred to as “delta pressure.” (See “Measuring Fuel Pressure” below for more details.) Ford Racing’s fuel injectors are always rated at 39.15psi delta, so the fuel injector sizing discussions found below will assume a fuel pressure of at least 39.15psi delta.

There are some exceptions to the above-mentioned nominal injection pressure. In relatively recent years, emissions regulations have become so stringent that the government is now regulating the emissions output that gasoline vehicles are allowed to produce even when the engine is not running! This is referred to as “evaporative emissions” and results from unburned hydrocarbons (raw fuel) emitting into the atmosphere from the fuel tank, fuel lines, injector leakage, intake manifold, etc. when the engine is shut off. This is the fundamental purpose of the charcoal canister (and hydrocarbon trap in the air-box on many vehicles) and is also the reason that Ford switched to the Returnless Fuel Systems (RFS) found in production vehicles today. These systems have only a fuel supply line from the tank to the engine, with no return line. The primary reason for these systems is that evaporative emissions increase as the temperature of the fuel in the tank increases. On a conventional return system, the fuel is sent to the engine through the supply line, and the excess is returned (via the mechanical fuel pressure regulator) to the tank through the return line. Since the engine is hot, this process heats up the fuel and thus increases evaporative emissions. To combat this, the returnless fuel systems were invented. Currently, Ford uses 2 primary types of RFS which are called Electronic Returnless Fuel System (ERFS) and Mechanical Returnless Fuel System (MRFS). The latter is the simpler of the two systems and controls the fuel rail to a constant pressure via a regulator in the tank, which is typically set to around 60psi. The Powertrain Control Module (PCM) then calculates the pressure across the injector either by inferring or measuring manifold pressure and subtracting from what it knows is the rail pressure set-point. ERFS, on the other hand, has no mechanical regulator at all, but instead has a Fuel Rail Pressure Transducer (FRPT) mounted on the fuel rail that measures fuel rail pressure relative to manifold pressure and feeds that information back to the PCM. The PCM then controls the Fuel Pump Driver Module (FPDM) which in turn varies the voltage to the fuel pump (or pumps) in the tank to supply the correct pressure and flow rate to the injectors. Most of the time this pressure is maintained at 39.15psi delta, but when the fuel temperature rises, this pressure can be boosted in order to delay the onset of boiling the fuel. Some vehicles also boost the pressure under some conditions in order to get away with using smaller flow-rate fuel injectors for various reasons beyond the scope of this tutorial. Both V6 and V8 Mustangs have used ERFS since the 1999 model year and continue to do so today. The purpose of going into all this detail is to convey the message that if you choose your fuel injectors based on a pressure of 39.15psi delta (which is the pressure at which Ford Racing specifies the flow rate), the injectors will be correctly sized regardless of which fuel system you actually have, and also to show you that fuel pressure on ERFS vehicles can change based on a number of conditions. These concepts will be important in the rest of this tutorial.

If you are trying to compare injector flow rates and you have flow data at one delta pressure, you can easily calculate the flow rate at a different delta pressure as follows:

**Flow rate at new delta pressure = (flow rate at old pressure) x  $\sqrt{\text{new pressure/old pressure}}$**

**Example: What is the flow rate for an injector at 43.5psi if it is rated at 60 lb/hr at 39.15psi?**

Flow rate at 43.5psi delta =  $60 \times \sqrt{43.5/39.15} = 63.2 \text{ lb/hr}$

You can use the following information to properly determine what size injectors are needed for various applications. For this example, we will use a naturally aspirated 5.0L V8 engine making 300 hp. Keep in mind that this is FLYWHEEL (also known as brake) horsepower, NOT wheel horsepower.

Engines require a certain fuel flow rate that is generally measured in lb/hr (pounds per hour) and can be calculated via knowledge of their Brake Specific Fuel Consumption (BSFC). By definition, BSFC represents how much fuel (in lb) is required per hour per each brake horsepower the engine produces. Most naturally aspirated production gasoline engines generally operate on a 0.42 to 0.52 lb/hp-hr BSFC at wide open throttle (WOT). High-performance gasoline and race engines (12.5:1 compression ratio and higher) which tend to be extremely efficient can sometimes have a BSFC as low as 0.38 to 0.42. More clearly stated, this means that if you have a gasoline engine that makes 300 brake horsepower, its total maximum fuel requirement in lb/hr can be calculated as follows:

**Fuel flow requirement = (brake horsepower) x (BSFC)**

**Example: A 300 hp naturally aspirated gasoline-powered V8 requires what size fuel injector?**

First, assume a BSFC of 0.50 lb/hr and injection pressure of 39.15psi across the injector.

$300 \text{ hp} \times 0.50 \text{ lb/hp-hr} = 150 \text{ lb/hr}$  maximum total fuel flow requirement

Since this is the total fuel flow requirement to the engine, we must now divide this by the number of injectors being used to determine the flow rate necessary for each injector so that you can select the correct size injector from this catalog. In this example, we have an 8-cylinder engine using 1 injector per cylinder, which gives: **150 lb/hr/8 injectors = 18.8 lb/hr per cylinder**



## PROPERLY SELECTING ELECTRONIC FUEL INJECTION COMPONENTS (continued...)

So, technically, the engine only needs a 19 lb/hr fuel injector to support 300 hp, but this will require that the injector is at nearly a 100% duty cycle in order to achieve this horsepower level. Duty cycle refers to how long the injector needs to be open (flowing fuel) in order to supply the required amount of fuel. If the injector needs a 100% duty cycle at a particular engine speed and load to inject enough fuel, that means it is open all the time. Under most conditions, fuel is injected when the intake valves are closed, which helps with fuel atomization and efficiency. If the injectors need to be on 100% of the time to supply enough fuel, this means that some fuel is being injected while the intake valves are open. Depending on the overlap of the cam in the engine, some of this unburned fuel can be blown right past the exhaust valve, or be poorly atomized, which makes for a less efficient combustion process. Perhaps more importantly, operating a fuel injector between roughly 85% and 99% duty cycle does not give the injector sufficient time to close before it is commanded to open again. This can cause extreme variability in the amount of fuel actually injected, which can sometimes result in a rich condition. Similar issues exist at the low end of the flow region at extremely low duty cycles, but this is highly dependent on the type and flow rate of each model of injector. In this case the injector does not have enough time to fully open before it is commanded to close again, which causes extreme variability that can result in a lean condition. For these reasons, we generally recommended selecting an injector with a flow rate sufficiently high that it will not be required to exceed an 85% duty cycle. So to figure out what size fuel injector will result in an 85% duty cycle, divide the original result by 0.85: **18.75 lb/hr/0.85 = 22.1 lb/hr requirement.**

Since the next popular injector size available is 24 lb/hr, this is the correct size injector that you should choose for this particular application. Keep in mind that this discussion assumes your fuel pump, lines, regulator, etc. are sufficient to be able to maintain at least 39.15psi across the injector at all engine speeds and loads (even under boost, if applicable). Now that you have selected an injector, the calibration (or "tune") in the PCM must either be changed or a different MAF must be used. (See "Mass Airflow Sensors" on page 217 for more details.)

This calculation can also be reversed to give the maximum safe hp a set of injectors can support, which gives:

$$\text{max safe hp} = [(\text{injector size}) \times (\text{total \# of injectors}) \times (\text{max duty cycle})] / \text{BSFC}$$

**Example:** The following guide is a general rule of thumb for sizing fuel injectors on an **8-cylinder engine** using a BSFC of 0.50. Forced-induction engines typically range from a BSFC of 0.55 to 0.65, with the latter value arising from the fuel enrichment necessary to keep exhaust temperatures below 1650 deg F and catalyst temperatures below 1700 deg F.

Naturally Aspirated:  $(19 \text{ lb} \times 8 \times .85) / .50 = 258.4$  or approx 258 hp @ 85% duty cycle  
Forced Induction @ 0.55:  $(19 \text{ lb} \times 8 \times .85) / .55 = 234.9$  or approx 235 hp @ 85% duty cycle  
Forced Induction @ 0.65:  $(19 \text{ lb} \times 8 \times .85) / .65 = 198.8$  or approx 199 hp @ 85% duty cycle

### Inj Flow Rate (@ 40psid)

19 lb/hr  
24 lb/hr  
30 lb/hr  
32 lb/hr  
39 lb/hr  
42 lb/hr  
47 lb/hr  
60 lb/hr

### Naturally Aspirated hp (@ 0.50)

258 hp @ 85% Duty Cycle  
326 hp @ 85% Duty Cycle  
408 hp @ 85% Duty Cycle  
435 hp @ 85% Duty Cycle  
530 hp @ 85% Duty Cycle  
571 hp @ 85% Duty Cycle  
639 hp @ 85% Duty Cycle  
816 hp @ 85% Duty Cycle

### Forced-Induction hp (@ 0.65)

199 hp @ 85% Duty Cycle  
251 hp @ 85% Duty Cycle  
314 hp @ 85% Duty Cycle  
335 hp @ 85% Duty Cycle  
408 hp @ 85% Duty Cycle  
439 hp @ 85% Duty Cycle  
492 hp @ 85% Duty Cycle  
628 hp @ 85% Duty Cycle

Remember, the above calculations assume a fuel pressure of 39.15psid. If you can raise fuel pressure and still be sure that your fuel pump can supply the desired flow rate, then these maximum horsepower numbers will increase.

### FUEL PUMPS

Most EFI fuel pumps are rated for flow at 12 volts @ 40psi. Most vehicle charging systems operate anywhere from 13.2 V to 14.4 V. Within limits, the more voltage you feed a pump (for a given current), the faster it spins, resulting in a higher output of fuel from the same fuel pump. Rating a fuel pump at 12 V should offer a fairly conservative fuel flow rating allowing you to safely determine the pump's ability to supply an adequate amount of fuel for a particular application, assuming the gauge of wire feeding power to the pump is sufficient to carry the current required.

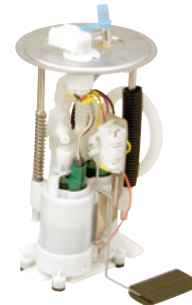

As previously mentioned, engines actually require a certain **mass** of fuel, NOT a certain **volume** of fuel per hour per horsepower. This can offer a bit of confusion since most fuel pumps are rated by volume, and not by mass. To determine the proper fuel pump required, a few mathematical conversions will need to be performed using the following information. There are 3.785 liters in 1 U.S. gallon and 1 gallon of gasoline (0.72 specific gravity @ 65° F) weighs 6.009 lb.

An additional fact to consider regarding the BSFC is that the specific gravity of the fuel that you are using is very important. The fuel that you put in your car should only be obtained from a source which supplies fuel intended for an automobile. Some people make the mistake of using aviation fuel (sometimes referred to as "Av Gas") thinking that the higher octane of this fuel may offer a performance gain. The problem is that TRUE aviation fuel has a much lower specific gravity (commonly as low as 0.62 to 0.65) than automotive grade fuel (0.72 to 0.76). Herein lies the problem: as previously stated, an engine requires a certain **mass** of fuel per hour per horsepower, and 1 gallon of aviation gasoline has a lower mass than 1 gallon of automotive gasoline. Since the specific gravity of aviation gasoline is only about 90% that of automotive gasoline, all other things being equal, your engine will run approximately 10% lean by using aviation gasoline. Be sure to take the specific gravity and stoichiometric ratio of your desired fuel into consideration when sizing the fuel pump and injectors.



## PROPERLY SELECTING ELECTRONIC FUEL INJECTION COMPONENTS (continued...)

It is always a good idea to apply a safety factor to account for things such as pump-to-pump variability, voltage loss between the pump and the battery, etc., so we recommend you multiply the final output of the fuel pump by 0.90 to determine the capacity of the fuel pump at 90% output to be on the safe side.

To determine the overall capacity of a fuel pump rated in liters per hour (L/hr), use the following additional conversions:

<i>Do:</i>	<i>To Get:</i>
(L/hr)/3.785	→ U.S. gallons/hr
Multiply above by 6.009 lb/gallon	→ lb/hr
Multiply above by 0.9	→ Capacity in lb/hr at 90%
Divide above by BSFC	→ "Horsepower Capacity" (flywheel)

So for a fuel pump rated at 110 L/hr for example, supplying a naturally aspirated engine:

110/3.785	= 29.06 U.S. gallons/hr
29.06 x 6.009	= 174.62 lb/hr
174.62 x 0.9	= 157 lb/hr @ 90% capacity
157/0.50	= 314 hp safe naturally aspirated "Horsepower Capacity"

### Safe "Horsepower Capacity" @ 40psi with 12 V assuming 0.5 lb/hp-hr BSFC

60 L/hr pump	= 95 lb/hr X 0.90	= 86 lb/hr, safe for up to 170 naturally aspirated flywheel hp
88 L/hr pump	= 140 lb/hr X 0.90	= 126 lb/hr, safe for up to 250 naturally aspirated flywheel hp
110 L/hr pump	= 175 lb/hr X 0.90	= 157 lb/hr, safe for up to 310 naturally aspirated flywheel hp
155 L/hr pump	= 246 lb/hr X 0.90	= 221 lb/hr, safe for up to 440 naturally aspirated flywheel hp
190 L/hr pump	= 302 lb/hr X 0.90	= 271 lb/hr, safe for up to 540 naturally aspirated flywheel hp
255 L/hr pump	= 405 lb/hr X 0.90	= 364 lb/hr, safe for up to 720 naturally aspirated flywheel hp

**Very Important Note:** For any type of forced-induction engine, the above maximum power levels will be reduced because as the boost pressure increases, the fuel pressure required from the pump also increases, creating an additional load to the fuel pump, which results in a decreased fuel flow rate at the higher pressure. In order to do proper fuel pump sizing for these applications, a fuel pump map is required, which shows flow rate versus delivery pressure for a given voltage. For example, a 255 L/hr pump at 40psi may only supply 200 L/hr at 58psi (40psi plus 18 lb of boost). Additionally, if you use a fuel supply line that is not large enough, this can result in decreased fuel flow due to the pressure drop. For example, a 255 L/hr at the pump may only result in 220 L/hr at the fuel rail because as the required pressure increases (due to the pressure loss from the supply line restriction), the maximum flow rate of the pump decreases. Figure 1 shows an example fuel pump map for a pump assembly at a supply voltage of 13 V.

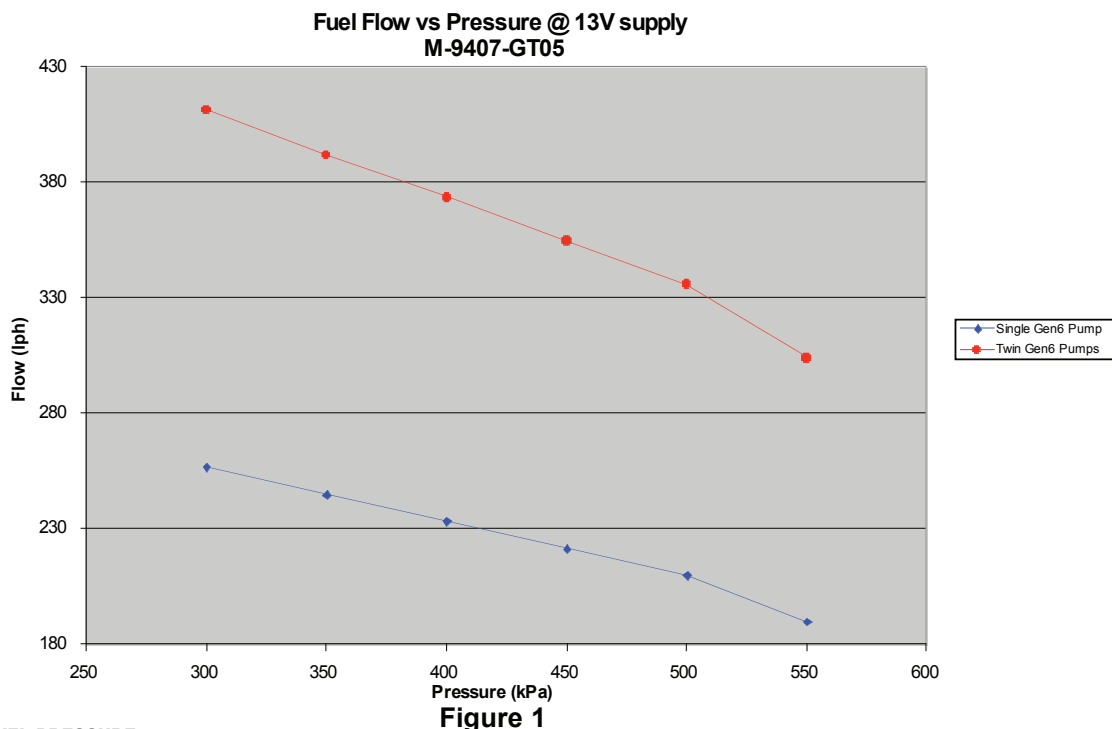

### MEASURING FUEL PRESSURE

The above fuel pump sizing information should be regarded as a **guideline** in selecting the size of pump you need. Once installed in the car, you still need to **verify** that adequate fuel pressure (at least 39.15psi across the injector) is maintained at all engine speeds and loads. Do not skip this fuel pressure verification step, as failure to maintain adequate fuel pressure can cause issues ranging from calibration difficulty to engine failure due to running lean.



## PROPERLY SELECTING ELECTRONIC FUEL INJECTION COMPONENTS (continued...)



As mentioned earlier, all injector flow rates published in this catalog have been determined at a pressure of 39.15psi (270kPa) across the injector, but what does the phrase “across the injector” mean? To understand this fully, we first need to discuss three different methods of measuring pressure.

The first is called **absolute** pressure. This is defined as the pressure relative to a complete vacuum, such as would be found in outer space. For instance, atmospheric pressure (the air we breathe) is typically around 14.7psi absolute (29.93inHg) at sea level, depending on temperature and weather conditions. An engine that has a vacuum signal of 12 “inches” simply means that the absolute pressure in the intake manifold is 12inHg less than the atmospheric pressure. When you subtract the 12inHg from the atmospheric pressure of 29.93inHg, you are left with a positive pressure of 17.93inHg, or roughly 9psi absolute as compared to a complete vacuum. Sometimes you will see absolute pressure in psi written as “psia.”

The second is called **gauge** pressure, which is pressure relative to atmospheric pressure. Gauge pressure is what everyone is most familiar with because it is what you measure when you check the air in your tires or when you connect a fuel pressure gauge to the fuel rail. An engine which makes 6psi of boost at sea level is actually equivalent to 20.7psi absolute ( $14.7 + 6 = 20.7$ ). Sometimes you will see gauge pressure in psi written as “psig.”

The third is called **delta** pressure and is very much like gauge pressure, but instead of being relative to atmospheric, it can be relative to any other pressure, such as the pressure in the intake manifold. Sometimes you will see delta pressure in psi written as “psid.”

When we quote pressure “across the injector,” what we really mean is the **delta** pressure (or difference) between the fuel rail and the intake manifold. On most EFI systems (non-MRFS), this is the pressure that the system controls, either by use of a mechanical regulator referenced to the intake manifold (in a traditional or “return” system), or by the use of the FRPT and the PCM (in ERFS). This means that if you connect a fuel rail pressure gauge to the fuel rail on one of these systems, you will see fuel pressure vary depending on intake manifold pressure. This is because the gauge is measuring gauge pressure, which is relative to atmospheric, but the EFI system is controlling the fuel rail pressure relative to intake manifold pressure which is changing depending on engine load (your right foot) among other things. On a naturally aspirated engine, the manifold pressure at idle is typically around 10psia, and the manifold pressure at Wide Open Throttle (WOT) will be atmospheric, so typically at the fuel rail you will see approximately 30psig at idle and at least 39.15psig at WOT, depending on whether or not you have ERFS and whether or not it is boosting pressure for one of the reasons mentioned in the previous section. On a forced-induction engine, the highest manifold pressure that the engine can reach will be atmospheric *plus* the maximum boost your configuration can obtain. This means that to keep 39.15psid across the injector, the gauge pressure will have to increase by the same amount as the maximum boost. A couple of examples should make these concepts more clear. First, consider a naturally aspirated conventional (non-ERFS, non-MRFS) EFI system with a mechanical regulator set at the stock pressure setting. The system will try to keep the pressure across the injector at 39.15psid regardless of engine load, so if you have a fuel pressure gauge attached to the fuel rail, you will see a maximum pressure of 39.15psig at WOT if the system is doing its job properly. Now consider a forced-induction engine making a maximum of 10psig boost, also with a conventional EFI system and mechanical regulator set to the stock pressure setting. The system will still try to keep the pressure across the injector at 39.15psi, so this time your fuel pressure gauge attached to the rail should read a maximum of  $39.15 + 10 = 49.15$ psig. If it never gets to 49.15psig at WOT, your fuel system is inadequate for your engine. You will need to either increase the capacity of the pump, minimize the voltage loss between the pump and the battery or decrease the pressure loss between the pump and the engine through the use of larger lines, etc., and re-test. Do NOT try to “tune around” this type of fuel delivery problem. It will bite you in the long run, and can result in hard-to-diagnose problems at best, all the way to engine failure at worst. Note that at WOT, the fuel pump in the forced-induction engine must supply fuel at a higher pressure than in the naturally aspirated engine. As mentioned in the previous section, this means that the fuel pump supplying the forced-induction engine will have a lower maximum flow rate capability than the fuel pump supplying the naturally aspirated engine. This is a critical concept to grasp because it means that in general, **for engines with equal brake horsepower, the fuel pump supplying the forced-induction engine will need to have more capacity than the fuel pump supplying the naturally aspirated engine!**

### **MASS AIRFLOW SENSORS**

On EFI systems that use a MAF sensor, this is the single most important sensor on the engine for determining a proper air/fuel (A/F) ratio. Unfortunately, it is also one of the most misunderstood sensors on the engine as well. The engine’s air/fuel ratio and spark advance are determined by the PCM primarily from the input received from the MAF sensor. This is also why it is of critical importance that there are no air leaks (defined as air entering the intake stream between the MAF and the combustion chamber) in a MAF-based system. Air leaks can cause a check-engine light, rough idling, stalling, spark knock, drivability issues and, in extreme cases, complete engine failure, depending on their magnitude.



## PROPERLY SELECTING ELECTRONIC FUEL INJECTION COMPONENTS (continued...)



As with fuel injectors, changing the MAF alone will not result in more horsepower on an otherwise stock engine. A different MAF sensor should only be considered after engine modification which either causes the stock sensor to become a flow restriction or when the stock MAF sensor electronics are insufficient to measure the airflow that the modified engine is capable of ingesting. This latter point is critical in understanding when a MAF needs to be replaced. It is possible to have 2 MAF sensors that are equal in size, but capable of different maximum power levels. This is because the electronics in each MAF are different and are capable of measuring different maximum airflow, despite the fact that the size of the MAF housing is the same. For example, you can have 2 different 90 mm MAF sensors but one will be capable of measuring 60 lb/min of air, while the other can measure, say, 100 lb/min of air. They both present the same airflow restriction (which is dictated primarily by their physical size) but they are definitely NOT interchangeable. So how do you know how much air your MAF needs to be capable of measuring? If you have an approximation of the engine's BSFC at WOT, as well as a target air/fuel ratio in mind, then the amount of air that your MAF sensor needs to be capable of measuring (in lb/hr) can be calculated as follows. Note that this formula includes a safety factor of 10%.

**Max airflow = 1.10 \* (Power \* BSFC \* A/F Ratio)**

**Example: What is the max airflow a naturally aspirated 300 hp gasoline engine will ingest?**

First, assume a BSFC of 0.50 lb/hp-hr and A/F ratio of 12:1.

Max airflow = 1.1 \* (300 \* 0.50 \* 12) = **1980 lb/hr**

Now that we know the minimum size fuel injector and MAF that we need, we have to consider what the PCM will do with this new hardware. The two main methods of dealing with the installation of a new MAF and injectors are to either "trick" the PCM by careful selection of injectors and a "matched" MAF, or by changing the calibration in the PCM to match the MAF and injectors that you selected.

The first method requires a MAF sensor that has been "curved" to a certain flow rate of injector. For instance, let's say your engine originally came with 19 lb/hr injectors and you replaced them with 39 lb/hr injectors. To use this method, you will need a MAF with electronics that have been modified such that it will output a signal proportional to an airflow that is 19/39 times as great as the stock MAF would measure. This will result in the PCM delivering the correct amount of fuel despite the fact that the injector size has been increased from 19 lb/hr to 39 lb/hr. The downside of this method is that many other variables such as spark advance are determined from the MAF sensor through a parameter called "load." For a given engine rpm, as load increases, required spark advance decreases. Since, by using this method, the MAF outputs a signal that is lower than the stock MAF, the calculated load will also be lower. This means that commanded spark advance will be higher than it should be, which can potentially result in spark knock, and other concerns. While this method works quite well on less sophisticated electronics, such as the EEC-IV found in Fox body Mustangs, it is not recommended for newer vehicles which have a much higher dependency on the calculated value of load.

The second, and preferred method requires the ability to alter the calibration inside the PCM, generally through the use of one of the aftermarket tools available. When using this method, the actual flow data for the injector (available on our website for all FRPP injectors), as well as the "transfer function" for the MAF are entered into the calibration in the PCM. Generally, it is recommended to test the new calibration on a dynamometer to ensure that the engine receives the correct A/F ratio at all speeds and loads. Provided this is performed by a competent and experienced tuner using proper equipment, this is by far the best method and will result in the best part-throttle drivability and idle, and the least amount of trouble with check-engine lights, returnless fuel, electronic throttle monitors, transmission shifting, etc.

Prior to tuning on a dyno, you should be absolutely certain that the ground circuits for the EFI system are in pristine condition. Doing so will help to ensure that the calibration you and your tuner develop on the dyno will also work when you leave. It can't be overstated that prior to the vehicle being tuned in any way, all vacuum leaks, electrical issues, etc., need to be resolved. Fixing them before you go to the dyno will always be cheaper than paying for dyno time while you're wrenching on your car.

As a *general rule of thumb*, the following stock Ford MAF sensors will safely support the corresponding horsepower:

<b>MAF Sensor</b>	<b>Approximate Max hp</b>
55 mm (Stock 1988-1993 Mustang)	275 hp
70 mm (Stock 1994-1995 Mustang)	350 hp
80 mm (Stock Ford)	425 hp
90 mm (M-12579-54)	540 hp



# IGNITION, FUEL SYSTEMS AND ELECTRICAL



## NOT ALL INJECTORS ARE ALIKE.

All Ford Racing injectors are held to the same original equipment specifications that are used in millions of Ford vehicles currently on the road. With mandatory emissions requirements for 100,000 miles, our injectors have to be durable and consistent. Some of our competitors' injectors are not built to original equipment standards and are often held to no specific build tolerance.

Don't trust your performance vehicle to just any injector, trust the brand with millions of vehicles on the road and over 100 years of racing experience, Ford Racing!

"After working with the Ford Racing 80 lb/hr injectors in several projects, I'm thoroughly convinced that they are the best all-around fuel injectors for most of today's Mustang performance applications; naturally aspirated and/or with power adders."

— KJ Jones, 5.0 Mustang & Super Fords

PART NUMBER (SETS OF 8)	FLOW RATE	IMPEDANCE	LENGTH	CONNECTOR	ADAPTOR	COLOR
<b>M-9593-LU24A</b> 	24 lb/hr	11-18 ohms	L	USCAR®	M-14464-A8	Black
<b>M-9593-MU32</b>	32 lb/hr	11-12 ohms	M	USCAR®	M-14464-A8	Black w/Red Stripe
<b>M-9593-LU34A</b>	34 lb/hr	11-18 ohms	L	USCAR®	M-14464-A8	Black
<b>M-9593-LU34K</b> 	34 lb/hr	11-18 ohms	L	Jetronic®/Minitimer®	Included	Black
<b>M-9593-M39</b>	39 lb/hr	11-18 ohms	L	USCAR®	M-14464-A8	Dark Blue
<b>M-9593-G302</b>	47 lb/hr	11-18 ohms	M	USCAR®	M-14464-A8	Black w/Yellow Stripe
<b>M-9593-LU47</b>	47 lb/hr	11-18 ohms	L	USCAR®	M-14464-A8	Black w/Silver Tip
<b>M-9593-LU60</b>	60 lb/hr	11-12 ohms	L	USCAR®	M-14464-A8	Black
<b>M-9593-LU80</b>	80 lb/hr	11-12 ohms	L	USCAR®	M-14464-A8	Black w/Blue Tip

All injector flow rates are quoted at a delta pressure of 39.15 psi. To convert to a delta pressure of 43.5 psi, multiply flow rate by 1.054.

## FUEL INJECTOR ADAPTOR KIT (JETRONIC® TO USCAR®)

**M-14464-A8**

- Adapts Jetronic®/Minitimer®-style harness to USCAR® fuel injectors
- Single-piece design for improved reliability and aesthetics over our competitors' adaptors
- Packaged in sets of (8)



## FUEL INJECTOR ADAPTOR KIT (USCAR® TO JETRONIC®)

**M-14464-U2J**

- Adapts USCAR®-style harness to Jetronic®/Minitimer®-style injector
- Single-piece design for improved reliability and aesthetics over our competitors' adaptors
- Packaged in sets of (8)

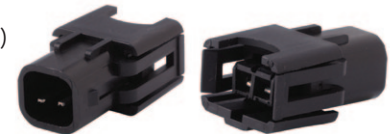

## BODY STYLE



## CONNECTORS



## LENGTH

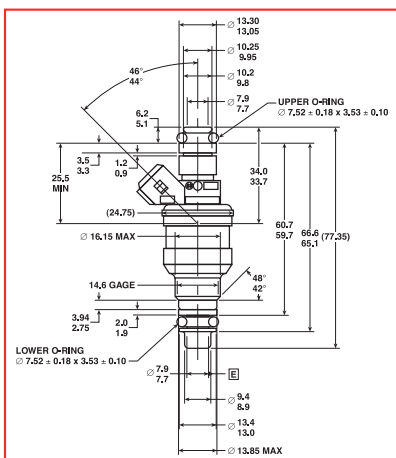

Long

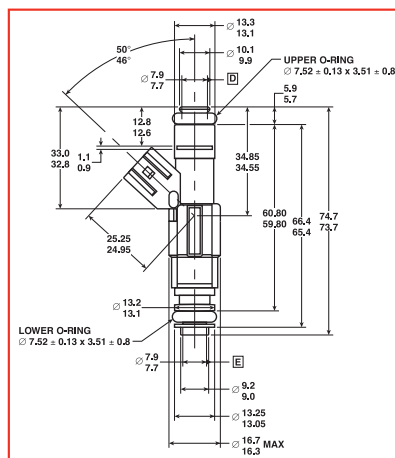

Long

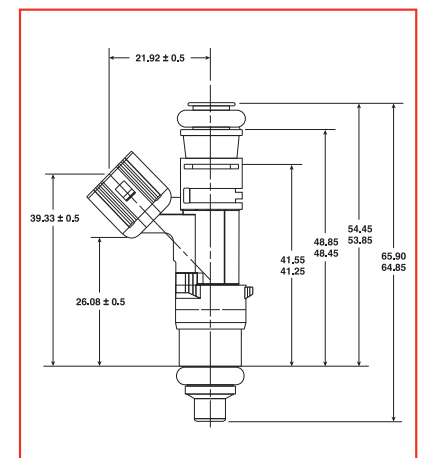

Medium

# IGNITION, FUEL SYSTEMS AND ELECTRICAL

## PROPERLY SELECTING ELECTRONIC FUEL INJECTION COMPONENTS

One of the more commonly misunderstood aspects of Electronic Fuel Injection (EFI) is how to select the correct size fuel injectors, fuel pump and Mass Air Flow (MAF) sensor for a particular engine horsepower output. The following information is intended to offer a very brief tutorial on properly selecting the most common EFI components.

### FUEL INJECTORS

First and foremost, adding larger fuel injectors alone will NOT create extra horsepower! The purchase of larger fuel injectors should only be considered when your engine has exceeded the horsepower capacity of the existing fuel injectors, at which point larger injectors are then required to SUPPORT the additional horsepower. If you add larger-than-stock injectors to an otherwise stock engine, you should not expect any horsepower increase whatsoever. In fact, you will most likely create many drivability issues that were not present before the swap to larger injectors.



The nominal injection pressure for many Ford EFI systems is 39.15 psi (270kPa) “across the injector.” The term “across the injector” takes manifold pressure and fuel rail pressure into account, and is usually referred to as “delta pressure.” (See “Measuring Fuel Pressure” on pages 214-215 for more details.) Ford Racing’s fuel injectors are always rated at 39.15 psi delta, so the fuel injector sizing discussions found below will assume a fuel pressure of at least 39.15 psi delta.

There are some exceptions to the above-mentioned nominal injection pressure. In relatively recent years, emissions regulations have become so stringent that the government is now regulating the emissions output that gasoline vehicles are allowed to produce even when the engine is not running! This is referred to as “evaporative emissions” and results from unburned hydrocarbons (raw fuel) emitting into the atmosphere from the fuel tank, fuel lines, injector leakage, intake manifold, etc., when the engine is shut off. This is the fundamental purpose of the charcoal canister (and hydrocarbon trap in the air-box on many vehicles) and is also the reason that Ford and other manufacturers switched to the Returnless Fuel Systems (RFS) found in production vehicles today. These systems have only a fuel supply line from the tank to the engine, with no return line. The primary reason for these systems is that evaporative emissions increase as the temperature of the fuel in the tank increases. On a conventional return system, the fuel is sent to the engine through the supply line, and the excess is returned (via the mechanical fuel pressure regulator) to the tank through the return line. Since the engine is hot, this process heats up the fuel and thus increases evaporative emissions. To combat this, the returnless fuel systems were invented. Currently, Ford uses 2 primary types of RFS which are called Electronic Returnless Fuel System (ERFS) and Mechanical Returnless Fuel System (MRFS). The latter is the simpler of the 2 systems and controls the fuel rail to a constant pressure via a (non-vacuum referenced) regulator in the tank, which is typically set to 55 psi. The Powertrain Control Module (PCM) then calculates the pressure across the injector, either by inferring or measuring manifold pressure and subtracting from the calibrated rail pressure set-point. This is referred to as a Constant Rail Pressure (CRP) system. ERFS, on the other hand, has no mechanical regulator at all, but instead has a Fuel Rail Pressure Transducer (FRPT) mounted on the fuel rail that measures fuel rail pressure relative to manifold pressure and feeds that information back to the PCM. The PCM then controls the Fuel Pump Driver Module (FPDM), which in turn varies the voltage to the fuel pump (or pumps) in the tank to supply the correct pressure and flow rate to the injectors. Most of the time this pressure is maintained at 39.15 psi delta, but when the fuel temperature rises, this pressure can be boosted in order to delay the onset of boiling the fuel. Some vehicles also boost the pressure under some conditions in order to get away with using smaller flow-rate fuel injectors for various reasons beyond the scope of this tutorial. This is referred to as a Constant Injection Pressure (CIP) system. Both V6 and V8 Mustang used ERFS between 1999 and 2010 and MRFS from 2011 forward.

If you are trying to compare injector flow rates and you have flow data at one delta pressure, you can easily calculate the flow rate at a different delta pressure as follows:

**Flow rate at new delta pressure = (flow rate at old pressure) x  $\sqrt{\text{new pressure/old pressure}}$**

**Example: What is the flow rate for an injector at 43.5 psi if it is rated at 60 lb/hr at 39.15 psi?**

Flow rate at 43.5 psi delta =  $60 \times \sqrt{43.5/39.15} = 63.2 \text{ lb/hr}$

You can use the following information to properly determine what size injectors are needed for various applications. For this example, we will use a naturally aspirated 5.0L V8 engine making 300 hp. Keep in mind, that this is FLYWHEEL (also known as brake) horsepower, NOT wheel horsepower.

Engines require a certain fuel flow rate that is generally measured in lb/hr (pounds per hour) and can be calculated via knowledge of its Brake Specific Fuel Consumption (BSFC). By definition, BSFC represents how much fuel (in lb) is required per hour per each brake horsepower the engine produces. Most naturally aspirated production gasoline engines generally operate on a 0.42 to 0.52 lb/hp-hr BSFC at wide open throttle (WOT). High-performance gasoline and race engines (12.5:1 compression ratio and higher), which tend to be extremely efficient, can sometimes have a BSFC as low as 0.38 to 0.42. More clearly stated, this means that if you have a gasoline engine that makes 300 brake horsepower, its total maximum fuel requirement in lb/hr can be calculated as follows:

**Fuel flow requirement = (brake horsepower) x (BSFC)**

**Example: A 300 hp naturally aspirated gasoline-powered V8 requires what size fuel injector?**

First, assume a BSFC of 0.50 lb/hr and injection pressure of 39.15 psi across the injector.

$300 \text{ hp} \times 0.50 \text{ lb/hp-hr} = 150 \text{ lb/hr}$  maximum total fuel flow requirement

Since this is the total fuel flow requirement to the engine, we must now divide this by the number of injectors being used to determine the flow rate necessary for each injector so that you can select the correct size injector from this catalog. In this example, we have an 8-cylinder engine using 1 injector per cylinder, which gives: **150 lb/hr/8 injectors = 18.8 lb/hr per cylinder**

## PROPERLY SELECTING ELECTRONIC FUEL INJECTION COMPONENTS (continued...)

So, technically, the engine only needs a 19 lb/hr fuel injector to support 300 hp, but this will require that the injector is at nearly a 100% duty cycle in order to achieve this horsepower level. Duty cycle refers to how long the injector needs to be open (flowing fuel) in order to supply the required amount of fuel. If the injector needs a 100% duty cycle at a particular engine speed and load to inject enough fuel, that means it is open all the time. Under most conditions, fuel is injected when the intake valves are closed, which helps with fuel atomization and efficiency. If the injectors need to be on 100% of the time to supply enough fuel, this means that some fuel is being injected while the intake valves are open. Depending on the overlap of the cam in the engine, some of this unburned fuel can be blown right past the exhaust valve, or be poorly atomized, which makes for a less-efficient combustion process. Perhaps more importantly, operating a fuel injector between roughly 85% and 99% duty cycle does not give the injector sufficient time to close before it is commanded to open again. This can cause extreme variability in the amount of fuel actually injected, which can sometimes result in a rich condition. Similar issues exist at the low end of the flow region at extremely low duty cycles, but this is highly dependent on the type and flow rate of each model of injector. In this case, the injector does not have enough time to fully open before it is commanded to close again, which causes extreme variability that can result in a lean condition. For these reasons, we generally recommended selecting an injector with a flow rate sufficiently high that it will not be required to exceed an 85% duty cycle. So, to figure out what size fuel injector will result in an 85% duty cycle, divide the original result by 0.85: **18.75 lb/hr/0.85 = 22.1 lb/hr requirement.**

Since the next popular injector size available is 24 lb/hr, this is the correct size injector that you should choose for this particular application. Keep in mind that this discussion assumes your fuel pump, lines, regulator, etc., are sufficient to be able to maintain at least 39.15 psi across the injector at all engine speeds and loads (even under boost, if applicable). Now that you have selected an injector, the calibration (or "tune") in the PCM must either be changed or a different MAF must be used (see "Mass Airflow Sensors" on page 216 for more details).

This calculation can also be reversed to give the maximum safe hp a set of injectors can support, which gives:

$$\text{Max safe hp} = [ (\text{injector size}) \times (\text{total \# of injectors}) \times (\text{max duty cycle}) ] / \text{BSFC}$$

**Example:** The following guide is general rule of thumb for sizing fuel injectors on an 8-cylinder engine using a BSFC of 0.50. Forced-induction engines typically range from a BSFC of 0.55 to 0.65, with the latter value arising from the fuel enrichment necessary to keep exhaust temperatures below 1650 deg F and catalyst temperatures below 1750 deg F.

Naturally Aspirated:  $(19 \text{ lb} \times 8 \times .85) / .50 = 258.4$  or approx 258 hp @ 85% duty cycle  
 Forced Induction @ 0.55:  $(19 \text{ lb} \times 8 \times .85) / .55 = 234.9$  or approx 235 hp @ 85% duty cycle  
 Forced Induction @ 0.65:  $(19 \text{ lb} \times 8 \times .85) / .65 = 198.8$  or approx 199 hp @ 85% duty cycle

### Inj Flow Rate (@ 40 psid)

24 lb/hr  
 30 lb/hr  
 32 lb/hr  
 39 lb/hr  
 47 lb/hr  
 60 lb/hr  
 80 lb/hr

### Naturally Aspirated hp (@ 0.50)

326 hp @ 85% Duty Cycle  
 408 hp @ 85% Duty Cycle  
 435 hp @ 85% Duty Cycle  
 530 hp @ 85% Duty Cycle  
 639 hp @ 85% Duty Cycle  
 816 hp @ 85% Duty Cycle  
 1088 hp @ 85% Duty Cycle

### Forced-Induction hp (@ 0.65)

251 hp @ 85% Duty Cycle  
 314 hp @ 85% Duty Cycle  
 335 hp @ 85% Duty Cycle  
 408 hp @ 85% Duty Cycle  
 492 hp @ 85% Duty Cycle  
 628 hp @ 85% Duty Cycle  
 837 hp @ 85% Duty Cycle

Remember, the above calculations assume a fuel pressure of 39.15 psid. If you can raise fuel pressure and still be sure that your fuel pump can supply the desired flow rate, then these maximum horsepower numbers will increase.

### FUEL PUMPS

Most EFI fuel pumps are rated for flow at 12 volts @ 40 psi. Most vehicle charging systems operate anywhere from 13.2 V to 14.4 V. Within limits, the more voltage you feed a pump (for a given current), the faster it spins, resulting in a higher output of fuel from the same fuel pump. Rating a fuel pump at 12 V should offer a fairly conservative fuel flow rating allowing you to safely determine the pump's ability to supply an adequate amount of fuel for a particular application, assuming the gauge of wire feeding power to the pump is sufficient to carry the current required.

As previously mentioned, engines actually require a certain **mass** of fuel, NOT a certain **volume** of fuel per hour per horsepower. This can offer a bit of confusion since most fuel pumps are rated by volume, and not by mass. To determine the proper fuel pump required, a few mathematical conversions will need to be performed using the following information. There are 3.785 liters in 1 U.S. gallon, and 1 gallon of gasoline (0.72 specific gravity @ 65° F) weighs 6.009 lb.

An additional fact to consider regarding the BSFC is that the specific gravity of the fuel that you are using is very important. The fuel that you put in your car should only be obtained from a source which supplies fuel intended for an automobile. Some people make the mistake of using aviation fuel (sometimes referred to as "Av Gas"), thinking that the higher octane of this fuel may offer a performance gain. The problem is that TRUE aviation fuel has a much lower specific gravity (commonly as low as 0.62 to 0.65) than automotive grade fuel (0.72 to 0.76). As previously stated, an engine requires a certain **mass** of fuel per hour per horsepower, and 1 gallon of aviation gasoline has a lower mass than 1 gallon of automotive gasoline. Since the specific gravity of aviation gasoline is only about 90% that of automotive gasoline, all other things being equal, your engine will run approximately 10% lean by using aviation gasoline. Be sure to take the specific gravity and stoichiometric ratio of your desired fuel into consideration when sizing the fuel pump and injectors. Note that the stoichiometric ratio is highly fuel dependent and should be obtained from the fuel supplier prior to performing any PCM calibration.

It is always a good idea to apply a safety factor to account for things such as pump-to-pump variability, voltage loss between the pump and the battery, etc., so we recommend you multiply the final output of the fuel pump by 0.90 to determine the capacity of the fuel pump at 90% output to be on the safe side.





# IGNITION, FUEL SYSTEMS AND ELECTRICAL

## PROPERLY SELECTING ELECTRONIC FUEL INJECTION COMPONENTS (continued...)

To determine the overall capacity of a fuel pump rated in liters per hour (L/hr), use the following additional conversions:

<i>Do:</i>	<i>To Get:</i>
(L/hr)/3.785	→ US gallons/hr
Multiply above by 6.009 lb/gallon	→ lb/hr
Multiply above by 0.9	→ Capacity in lb/hr at 90%
Divide above by BSFC	→ "Horsepower Capacity" (flywheel)

So, for a fuel pump rated at 110 L/hr for example, supplying a naturally aspirated engine:

110/3.785	= 29.06 U.S. gallons/hr
29.06 x 6.009	= 174.62 lb/hr
174.62 x 0.90	= 157 lb/hr @ 90% Capacity
157/0.50	= 314 hp safe naturally aspirated "Horsepower Capacity"

### Safe "Horsepower Capacity" @ 40 psi with 12 V assuming 0.5 lb/hp-hr BSFC

60 L/hr pump = 95 lb/hr x 0.90	=86 lb/hr, safe for up to 170 naturally aspirated flywheel hp
88 L/hr pump = 140 lb/hr x 0.90	=126 lb/hr, safe for up to 250 naturally aspirated flywheel hp
110 L/hr pump = 175 lb/hr x 0.90	=157 lb/hr, safe for up to 310 naturally aspirated flywheel hp
155 L/hr pump = 246 lb/hr x 0.90	=221 lb/hr, safe for up to 440 naturally aspirated flywheel hp
190 L/hr pump = 302 lb/hr x 0.90	=271 lb/hr, safe for up to 540 naturally aspirated flywheel hp
255 L/hr pump = 405 lb/hr x 0.90	=364 lb/hr, safe for up to 720 naturally aspirated flywheel hp

**Very Important Note:** For any type of forced-induction engine, the above maximum power levels will be reduced because as the boost pressure increases, the fuel pressure required from the pump also increases, creating an additional load to the fuel pump, which results in a decreased fuel flow rate at the higher pressure. In order to do proper fuel pump sizing for these applications, a fuel pump map is required, which shows flow rate versus delivery pressure for a given voltage. For example, a 255 L/hr pump at 40 psi may only supply 200 L/hr at 58 psi (40 psi plus 18 lbs of boost). Additionally, if you use a fuel supply line that is not large enough, this can result in decreased fuel flow due to the pressure drop. For example, 255 L/hr at the pump may only result in 220 L/hr at the fuel rail because as the required pressure increases (due to the pressure loss from the supply line restriction), the maximum flow rate of the pump decreases. Figure 1 shows an example fuel pump map for a pump assembly at a supply voltage of 13 V.

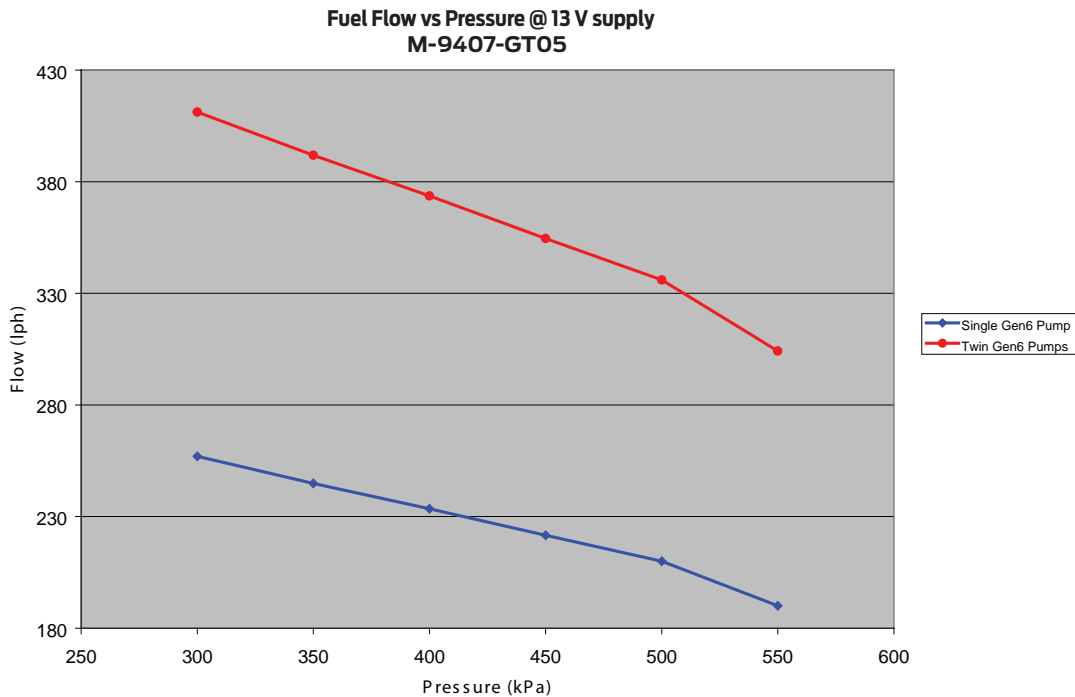

Figure 1

### MEASURING FUEL PRESSURE

The above fuel pump sizing information should be regarded as a **guideline** in selecting the size of pump you need. Once installed in the car, you still need to **verify** that adequate fuel pressure (at least 39.15 psi across the injector) is maintained at all engine speeds and loads. Do not skip this fuel pressure verification step, as failure to maintain adequate fuel pressure can cause issues ranging from calibration difficulty to engine failure due to running lean.

## PROPERLY SELECTING ELECTRONIC FUEL INJECTION COMPONENTS (continued...)



As mentioned earlier, all injector flow rates published in this catalog have been determined at a pressure of 39.15 psi (270kPa) across the injector, but to what does the phrase “across the injector” refer? To understand this fully, we first need to discuss three different methods of measuring pressure.

The first is called **absolute** pressure. This is defined as the pressure relative to a complete vacuum, such as would be found in outer space. For instance, atmospheric pressure (the air we breathe) is typically around 14.7 psi absolute (29.93inHg) at sea level, depending on temperature and weather conditions. An engine that has a vacuum signal of 12 “inches” simply means that the absolute pressure in the intake manifold is 12inHg less than the atmospheric pressure. When you subtract the 12inHg from the atmospheric pressure of 29.93inHg, you are left with a positive pressure of 17.93inHg, or roughly 9 psi absolute as compared to a complete vacuum. Sometimes you will see absolute pressure in psi written as “psia.”

The second is called **gauge** pressure, which is pressure relative to atmospheric pressure. In general, everyone is most familiar with gauge pressure, because it is what you measure when you check the air in your tires or when you connect a fuel pressure gauge to the fuel rail. An engine which makes 6 psi of boost at sea level is actually equivalent to 20.7 psi absolute, (14.7 + 6 = 20.7). Sometimes you will see gauge pressure in psi written as “psig.”

The third is called **delta** pressure and is very much like gauge pressure, but instead of being relative to atmospheric, it can be relative to any other pressure, such as the pressure in the intake manifold. Sometimes you will see delta pressure in psi written as “psid.”

When we quote pressure “across the injector,” what we really mean is the delta pressure (or difference) between the fuel rail and the intake manifold. On CRP systems, the rail gauge pressure is constant while the delta pressure varies depending on manifold pressure. This means if a fuel pressure gauge is connected to the rail, the reading it gives will be constant. On CIP systems, the system controls the delta pressure, either by use of a mechanical regulator referenced to the intake manifold (in a traditional or “return” system), or by the use of the FRPT and the PCM (with ERFs). This means that if you connect a fuel pressure gauge to the fuel rail on one of these systems, you will see fuel pressure vary depending on intake manifold pressure. This is because the gauge is measuring gauge pressure, which is relative to atmospheric, but the EFI system is controlling the fuel rail pressure relative to intake manifold pressure which is changing depending on engine load (your right foot) among other things. On a naturally aspirated engine, the manifold pressure at idle is typically around 10 psia, and the manifold pressure at WOT will be atmospheric, so typically at the fuel rail you will see approximately 30 psig at idle and at least 39.15 psig at WOT, depending on whether or not you have ERFs and whether or not it is boosting pressure for one of the reasons mentioned in the previous section. On a forced-induction engine, the highest manifold pressure that the engine can reach will be atmospheric plus the maximum boost your configuration can obtain. This means that to keep 39.15 psid across the injector, the gauge pressure will have to increase by the same amount as the maximum boost. A couple of examples should make these concepts more clear. First, consider a naturally aspirated conventional return fuel (non-ERFS, non-MRFS) EFI system with a mechanical vacuum referenced regulator set at the stock pressure setting. The system will try to keep the pressure across the injector at 39.15 psid regardless of engine load, so if you have a fuel pressure gauge attached to the fuel rail, you will see a maximum pressure of 39.15 psig at WOT if the system is doing its job properly. Now consider a forced-induction engine making a maximum of 10 psig boost, also with a conventional EFI system and mechanical regulator set to the stock pressure setting. The system will still try to keep the pressure across the injector at 39.15 psi, so this time your fuel pressure gauge attached to the rail should read a maximum of  $39.15 + 10 = 49.15$  psig. If it never gets to 49.15 psig at WOT, your fuel system is inadequate for your engine. You will need to either increase the capacity of the pump, minimize the voltage loss between the pump and the battery or decrease the pressure loss between the pump and the engine through the use of larger lines, etc., and re-test. Do NOT try to “tune around” this type of fuel delivery problem. It will bite you in the long run, and can result in hard-to-diagnose problems at best all the way to engine failure at worst. Note that during a WOT event, the fuel pump in the forced-induction engine must supply fuel at a higher pressure than in the naturally aspirated engine. As mentioned in the previous section, this means that the fuel pump supplying the forced-induction engine will have a lower maximum flow rate capability than the fuel pump supplying the naturally aspirated engine. This is a critical concept to grasp because it means that in general, **for engines with equal brake horsepower, the fuel pump supplying the forced-induction engine will need to have more capacity than the fuel pump supplying the naturally aspirated engine!**

## PROPERLY SELECTING ELECTRONIC FUEL INJECTION COMPONENTS (continued...)

### MASS AIRFLOW SENSORS

On EFI systems that use a MAF sensor, this is the single most important sensor on the engine for determining a proper Air/Fuel (A/F) ratio. Unfortunately, it is also one of the most misunderstood sensors on the engine, as well. The engine's air/fuel ratio and spark advance are determined by the PCM primarily from the input received from the MAF sensor. This is also why it is of critical importance that there are no air leaks (defined as air entering the intake stream between the MAF and the combustion chamber) in an MAF-based system. Air leaks can cause a "Check Engine" light, rough idling, stalling, spark knock, electronic throttle control failure mitigation modes, drivability issues, and in extreme cases, complete engine failure, depending on their magnitude.



As with fuel injectors, changing the MAF alone will not result in more horsepower on an otherwise stock engine. A different MAF sensor should only be considered after engine modification which either causes the stock sensor to become a flow restriction **or** when the stock MAF sensor electronics are insufficient to measure the airflow that the modified engine is capable of ingesting. This latter point is critical in understanding when a MAF needs to be replaced. It is possible to have 2 MAF sensors that are equal in size, but capable of different maximum power levels. This is because the electronics in each MAF are different and are capable of measuring different maximum airflow, despite the fact that the size of the MAF housing is the same. For example, you can have two different 90 mm MAF sensors but one will be capable of measuring 60 lb/min of air, while the other can measure, say, 100 lb/min of air. They both present the same airflow restriction (which is dictated primarily by their physical size) but they are definitely NOT interchangeable. So how do you know how much air your MAF needs to be capable of measuring? If you have an approximation of the engine's BSFC at WOT, as well as a target air/fuel ratio in mind, the amount of air that your MAF sensor needs to be capable of measuring (in lb/hr) can be calculated as follows. Note that this formula includes a safety factor of 10%.

#### Max airflow = 1.10 x (Power x BSFC x A/F Ratio)

#### **Example: What is the max airflow a naturally aspirated 300 hp gasoline engine will ingest?**

First, assume a BSFC of 0.50 lb/hp-hr and A/F ratio of 12:1.

Max airflow = 1.1 x (300 x 0.50 x 12) = **1980 lb/hr**

Now that we know the minimum size fuel injector and MAF that we need, we have to consider what the PCM will do with this new hardware. The two main methods of dealing with the installation of a new MAF and injectors are to either "trick" the PCM by careful selection of injectors and a "matched" MAF, or by changing the calibration in the PCM to match the MAF and injectors that you selected.

The first method requires a MAF sensor that has been "curved" to a certain flow rate of injector. For instance, let's say your engine originally came with 19 lb/hr injectors and you replaced them with 39 lb/hr injectors. To use this method, you will need a MAF with electronics that have been modified such that it will output a signal proportional to an airflow that is 19/39 times as great as the stock MAF would measure. This will result in the PCM delivering the correct amount of fuel despite the fact that the injector size has been increased from 19 lb/hr to 39 lb/hr. The downside of this method is that many other variables such as spark advance are determined from the MAF sensor through a parameter called "load." For a given engine RPM, as load increases, required spark advance decreases. Since, by using this method, the MAF outputs a signal that is lower than the stock MAF, the calculated load will also be lower. This means that commanded spark advance will be higher than it should be, which can potentially result in spark knock and other concerns. While this method works quite well on less-sophisticated electronics, such as the EEC-IV found in a Fox-body Mustang, it is not recommended for newer vehicles which have a much higher dependency on the calculated value of load.

The second, and much preferred method requires the ability to alter the calibration inside the PCM. When using this method, the actual flow data for the injector (available on our website for all FRPP injectors), as well as the "transfer function" for the MAF are entered into the calibration in the PCM. Generally, it is recommended to test the new calibration on a dynamometer to ensure that the engine receives the correct A/F ratio at all speeds and loads. Provided this is performed by a competent and experienced operator using proper equipment, this is by far the best method and will result in the best part-throttle drivability and idle, and the least amount of trouble with "Check Engine" lights, returnless fuel, electronic throttle monitors, transmission shifting, etc. Ford Racing performance upgrade kits and their associated calibrations are designed to work together seamlessly, taking much of the hard work out of upgrading the performance of your vehicle.

Prior to tuning on a dyno, you should be absolutely certain that the ground circuits for the EFI system are in pristine condition. Doing so will help to ensure that the calibration you and your tuner develop on the dyno will also work when you leave the shop. It can't be overstated that prior to the vehicle being tuned in any way, all vacuum leaks, electrical issues, etc., need to be resolved. Fixing them before you go to the dyno will always be cheaper than paying for dyno time while you're wrenching on your car.

## EFI SYSTEM TIPS

Always remember to disconnect the battery before doing any wiring on your vehicle!

### **ELECTRICAL GROUNDS**

The single leading cause of most electrical problems is poor grounds.

Ideally, the ground for the fuel injection system should connect directly to the battery at the negative post. Using the steel chassis or engine block as a ground can create excessive resistance causing the Powertrain Control Module (PCM) to function improperly.



An example of how a high ground or connection resistance can have very serious effects is as follows. This particular case applies to a 2005 Mustang GT, but can easily be extended to any electronically controlled Ford vehicle: consider the case where a PCM is reading a MAF sensor signal of 4.1 V (due to a high ground or connection resistance) when it should really be reading 4.3 V. This equates to a difference in measured air mass of 13%. That is, the MAF will be telling the PCM that there is 13% less air entering the engine than there really is. Let's say this happens at WOT, where air/fuel ratio is critical not only to performance, but also to engine durability. The result is that the actual air/fuel ratio can go from a safe 12.5:1 to a potentially damaging 14.1:1, just from a 0.2 V change in the MAF return signal!

All PCM sensors, not just the MAF, are affected in a similar fashion, so it is absolutely critical that all electrical connections are solid and that the grounds are reliable. The potential penalty for a bad ground can range from strange drivability issues that are difficult to diagnose all the way to a damaged engine, as in the above example.

All resistance tests should be done with the ignition key in the off position. Having voltage going through the system can return a false reading of excessive resistance. Additionally, it is possible to have a ground that tests OK when the engine is cold, but not when the engine is hot. Heat increases resistance, so these tests should be performed on a warm engine when possible.

To test for an adequate ground circuit in the EFI system for a 1986 to 1993 5.0L Mustang, use a Volt/Ohm meter to check the resistance of the following circuits:

- **To verify a proper ground to the PCM**, check the resistance from pin 40 and pin 60 DIRECTLY to the negative side of the battery. Resistance should be no greater than 0.2 ohms.
- **To verify a proper ground to the main PCM harness**, check the resistance from the MAF sensor at pin 'B' DIRECTLY to the negative side of the battery. Resistance should be no greater than 0.2 ohms.
- **To verify a proper ground to the engine harness**, check the resistance from the black wire at the Throttle Position Sensor (TPS) DIRECTLY to the negative side of the battery. Resistance should be no greater than 0.3 ohms.

Note that while 0.2 ohms or less is desirable, a resistance as high as 0.5 ohms is considered acceptable. Greater than 0.5 ohms is excessive and could result in drivability concerns.

A weak ground connection can also cause the PCM's internal reference voltage regulator to function incorrectly. This can be checked at the TPS by checking voltage between the black ground wire and the orange reference voltage wire. With the key on, this voltage signal should be somewhere between 4.7 V and 5.3 V.

### **GENERAL TIPS**

- Whenever possible, the PCM should be mounted inside the vehicle to protect it from water damage. The PCM should also be mounted with the electrical connectors at the bottom to avoid trapping water. Some PCMs on newer model cars are mounted under the hood, but they are sealed against moisture and designed to operate in such an environment. When in doubt, mount the PCM inside the vehicle.

# IGNITION, FUEL SYSTEMS AND ELECTRICAL

## EFI SYSTEM TIPS (continued...)

- When setting the voltage at the TPS, you should check the voltage between the black and green wires (1986-1993 5.0L Mustang). This voltage should be somewhere between 0.96 V and 0.98 V. If the key is on while the engine is off, set the voltage at 0.96 V. If the engine is running, set it at 0.98 V. The TPS can be set by loosening the mounting screws and slightly rotating the sensor. If you are unable to achieve the proper setting, you may need to elongate the TPS mounting holes.
- If you ever need to lengthen any harness leads for your specific application, it is strongly advised that you lengthen only one wire at a time, which will help to avoid making mistakes.
- If you are using long tube headers, and need to lengthen the leads of the harness to reach the Heated Exhaust Gas Oxygen (HEGO, also known as O<sub>2</sub> or oxygen) sensors, NEVER lengthen the wires of the O<sub>2</sub> sensor itself. These wires are made up of a unique material and you will disrupt the signal coming from the O<sub>2</sub> sensor **even if they are soldered correctly!** If you must increase the length of the leads to the O<sub>2</sub> sensor, always lengthen the wires on the wiring harness side of the O<sub>2</sub> sensor. Many aftermarket companies offer HEGO sensor extensions that work quite well and are a quick and easy solution to this problem.
- When soldering two or more wires together, you should “tin” the bare ends to be soldered. This will prevent cold solder joints and make the process easier. “Crimp” style or “solder-less” connectors are not recommended. Over time, these have a tendency to loosen and permit corrosion. Additionally, these connectors can commonly allow short circuits to develop within the connection. Many of these problems within the harness can be difficult to locate. Always use weather-tight heat shrink over all soldered joints.
- If the factory coolant tubes are not used, the Engine Coolant Temperature (ECT) sensor should be installed directly into the threaded boss in the intake manifold near the thermostat, if applicable. This is a coolant passage.
- The ACT sensor should generally not be moved from the stock location. Some aftermarket companies offer ACT relocation kits while making false claims of increased horsepower by reading cooler air. While it is true that a cooler air can result in more power, this “trick” is not cooling the incoming air, but instead is merely reading the temperature from a different location. This can have a negative effect on overall engine performance and drivability because the PCM was calibrated under the assumption that the ACT sensor was in the stock design location. On a forced-induction engine, it is generally preferable to have the ACT sensor located after the power adder and after the intercooler, if applicable, which will simplify the calibration (“tuning”) process. Some of our FRPP supercharger kits leave the ACT sensor in the stock location upstream of the supercharger, but this was accounted for in the calibration and should not be changed.
- Protect the air filter element from turbulence created by the engine cooling fan. This is commonly referred to as “fan wash.” If you are using an open element air filter on the end of the MAF sensor, it is strongly advised that you use a shield to reduce the effects of the turbulence.
- It's best if the air filter gets cold air from in front of the radiator. If the filter is located in the engine compartment, as in many street rod applications, the inlet air temperature can be up to 60 degrees hotter than ambient which can result in a 5% torque loss from the air density decrease. The PCM will also retard ignition timing for the hotter air which can result in an additional 5-10% torque loss. Colder air is always better.
- An improperly functioning charging system can cause engine running problems. Under-drive pulleys spin the accessories slower meaning that they consume less power from the engine. This results in a greater net horsepower available at the flywheel, but at a cost. Normally this is not a problem, but some systems may not perform properly if you under-drive the alternator excessively, especially if you've increased the electrical load on the system through the use of bigger cooling fans, high-capacity fuel pump, stereo system, etc. If the alternator does not generate enough voltage to keep the system adequately charged, it can have an adverse effect on the EFI system and result in a variety of drivability issues.
- The inside diameter of the fuel return line should be at least 75% of the size of the inside diameter of the fuel supply line.

## FUEL PUMP LOCATION

A common and often overlooked problem is the location of the fuel pump or pumps. Optimally, the fuel pump should be mounted IN THE TANK to reduce the possibility of pump cavitation. Cavitation is essentially localized boiling caused by a reduction in pressure, generally occurring on the inlet side of a pump. This localized boiling results in fuel vapor bubbles which will reduce the volume of fuel the pump is capable of delivering to the engine. Any reduction in pressure or increase in temperature at the inlet side of the pump increases the chances that cavitation will occur. For this reason, it is always best to either have the pump inside the tank immersed in fuel or (in the case of an external pump) gravity fed, which will increase the pressure on the inlet side of the pump. If the fuel pump has to “pull” the fuel, this will result in a reduction in pressure at the fuel pump inlet potentially allowing cavitation and, thus, vapor bubbles to develop. These vapor bubbles are then drawn into the fuel pump and exit the high-pressure side of the fuel pump as compressed vapor. They travel the entire length of the fuel system and are expelled through the fuel injector. This can cause issues ranging from stumbles and hesitations to engine damage due to insufficient fuel delivery and lean A/F ratios. Sometimes this problem can characterize itself by only appearing when the weather gets warmer, which can confound the diagnosis of the issue. In certain cases, it may seem to only develop when driving on certain surfaces, because pavement reflects more heat than an off-road 4x4 trail. Remember, more heat and lower pressure on the inlet side of the pump means a greater chance of cavitation, which is to be avoided whenever possible.

If you are using an external-mounted fuel pump, you should run a very coarse (typically around 100 micron) filter on the inlet side of the fuel pump, and a finer (typically around 10 micron) filter on the outlet side of the pump. A paper filter is NOT recommended on the inlet of the fuel pump because it can cause a restriction in fuel flow which, as mentioned previously, can lead to cavitation.