

**!!! PLEASE READ ALL OF THE FOLLOWING INSTRUCTIONS CAREFULLY PRIOR TO INSTALLATION.**

**OVERVIEW:**

The use of a floor hoist is recommended for this installation. If you do not have access to one, use a hydraulic floor jack and jack stands to raise the vehicle.

**!!! CAUTION: JACK STANDS MUST BE USED ON A LEVEL SURFACE AND BE SECURELY SEATED. FAILURE TO DO SO MAY RESULT IN PERSONAL INJURY OR VEHICLE DAMAGE !!!**

**Kit Includes:**

<b>Item #</b>	<b>Qty:</b>	<b>Description</b>
M-5251-M8	1	X-Pipe
33226	2	Clamp

**Image of New X-Pipe:**





FORD PERFORMANCE

# Part Number: M-5251-M8 2015 5.0L X-Pipe Exhaust System INSTALLATION INSTRUCTIONS

Image of current Exhaust System:

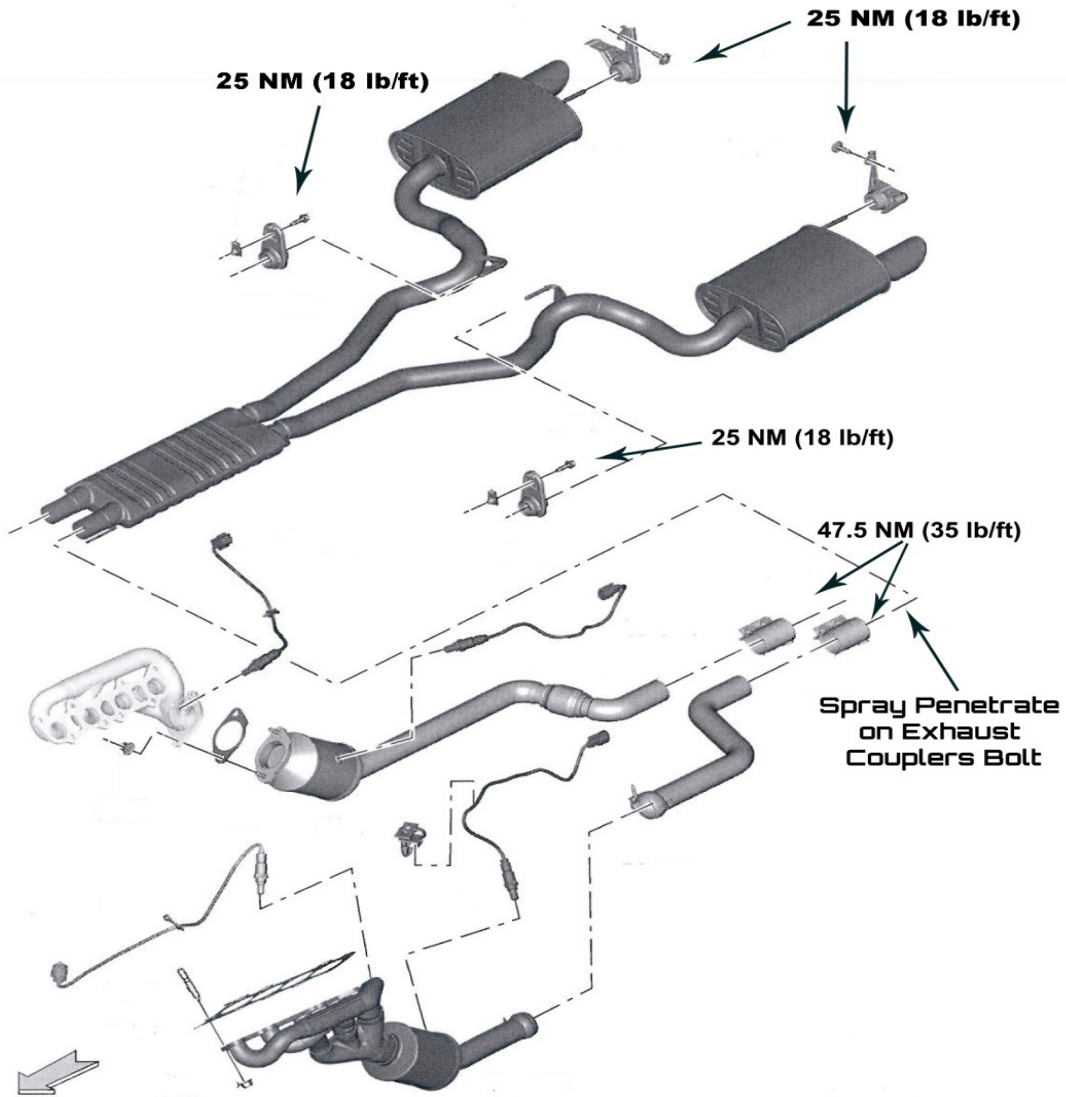



FORD PERFORMANCE

## Part Number: M-5251-M8 2015 5.0L X-Pipe Exhaust System INSTALLATION INSTRUCTIONS

### MUFFLER AND TAILPIPE:

#### Removal

**NOTE:** Do not excessively bend, twist or allow the exhaust to hang from the flexible joint or damage to the exhaust system may occur.

**NOTE:** Do not use oil or grease-based lubricants on the isolators. They may cause deterioration of the rubber.

**NOTE:** Removal steps in this procedure may contain installation details.

**STEP 1:** With the vehicle in NEUTRAL, position it on a hoist.

**STEP 2:** If equipped, remove the retainers and the brace.  
Torque: 46 lb.ft (63 Nm)

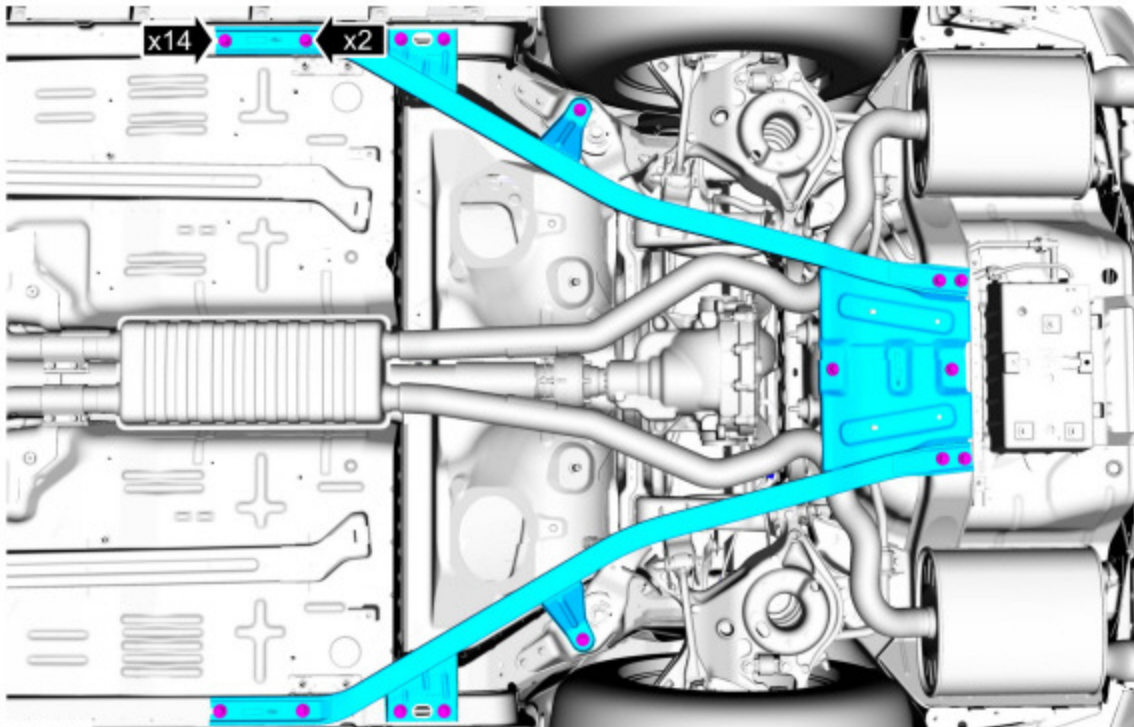



FORD PERFORMANCE

**Part Number: M-5251-M8**  
**2015 5.0L X-Pipe Exhaust System**  
**INSTALLATION INSTRUCTIONS**

**STEP 3:** Loosen the clamps and separate the muffler and tailpipe from the RH catalytic converter and LH muffler inlet pipe.

*Torque: 35 lb.ft (48 Nm)*

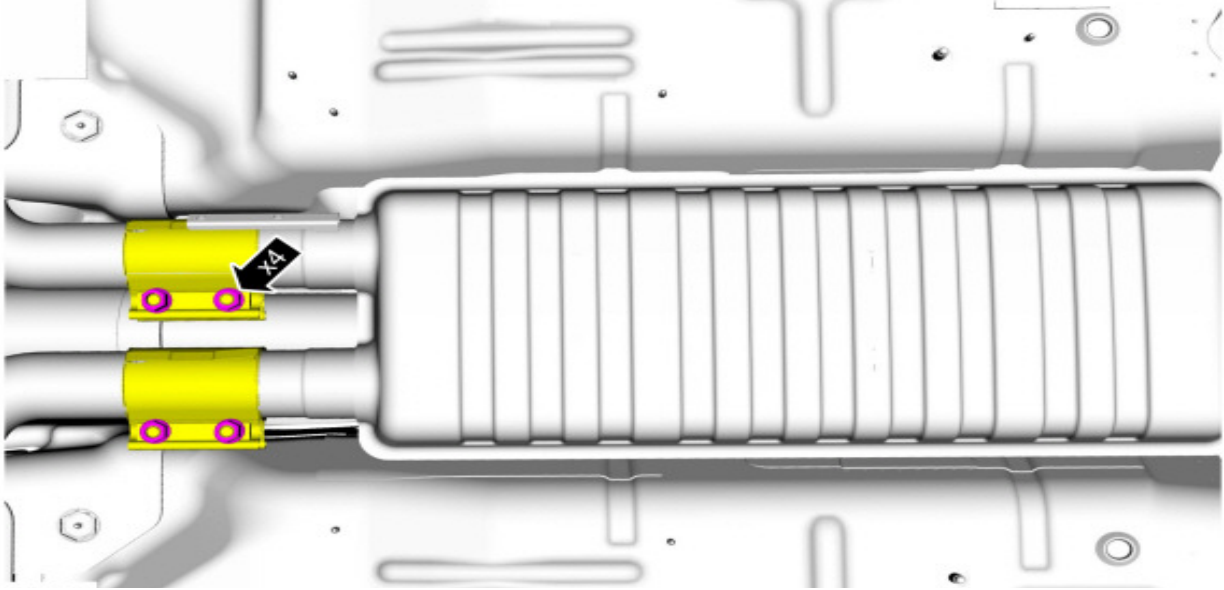

**STEP 4:** Remove the LH and RH rear exhaust hanger isolator bracket bolts. Unhook the rear exhaust hanger isolators and remove the muffler and tailpipe.

*Torque: 18 lb.ft (25 Nm)*

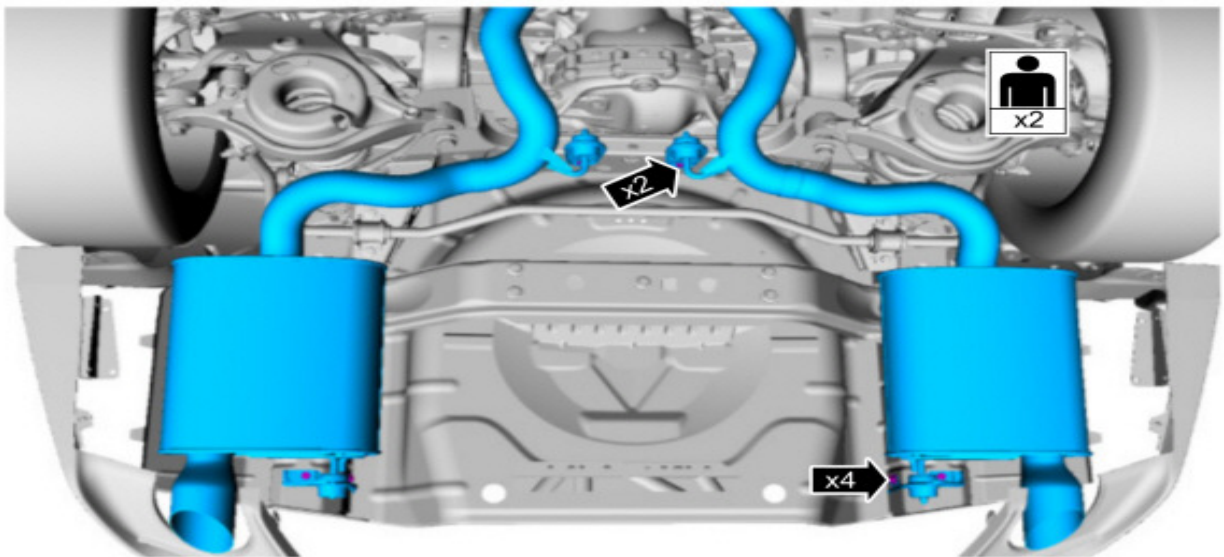





FORD PERFORMANCE

## Part Number: M-5251-M8 2015 5.0L X-Pipe Exhaust System INSTALLATION INSTRUCTIONS

**STEP 5:** With the muffler and tailpipe on the floor, remove the clamps and slide back onto the RH catalytic converter and LH muffler inlet pipe. Now cut the pipes at the exit of the muffler. See picture below.



**STEP 6:** Slide the X-pipe into RH catalytic converter and LH muffler inlet pipe clamps. Making sure to center the clamps between the two pipes. Snug both clamps to hold X-pipe in place.



**STEP 7:** Installation of the muffler and tailpipe, reverse the removal procedure.

**STEP 8:** Install supplied clamps onto X-pipe and tailpipes.



**STEP 9:** Align system in rear facial and torque factory clamps to 35 lb.ft (48 Nm) and the supplied clamps to 40 lb ft (50Nm)

