



Part Number: M-20201-M/GT350
Part Description: Mustang [Strut Tower Brace Kit](#)
INSTALLATION INSTRUCTIONS

NO PART OF THIS DOCUMENT MAY BE REPRODUCED WITHOUT PRIOR AGREEMENT AND WRITTEN PERMISSION OF FORD PERFORMANCE PARTS.

!!! PLEASE READ ALL OF THE FOLLOWING INSTRUCTIONS CAREFULLY PRIOR TO INSTALLATION.

OVERVIEW:

Park vehicle on a flat / level surface!

Strut Tower Brace



Strut Tower Brace Kit Contains the Following

- 1** **Strut Tower Brace**
- 1** **Steel Cowl Extension**
- 4** **Nuts**



Part Number: M-20201-M/GT350
Part Description: Mustang [Strut Tower Brace Kit](#)
INSTALLATION INSTRUCTIONS

NO PART OF THIS DOCUMENT MAY BE REPRODUCED WITHOUT PRIOR AGREEMENT AND WRITTEN PERMISSION OF FORD PERFORMANCE PARTS.

If your car is factory equipped with a steel cowl extension it is the same as Ford Performance steel cowl extension. Removal is not necessary.

Battery Disconnect and Connect

Disconnect

NOTE: *When the battery is disconnected and connected, some abnormal drive symptoms may occur while the vehicle relearns its adaptive strategy. The vehicle may need to be driven to allow the PCM to relearn the adaptive strategy values.*

1. Remove the retainers and the battery cover.

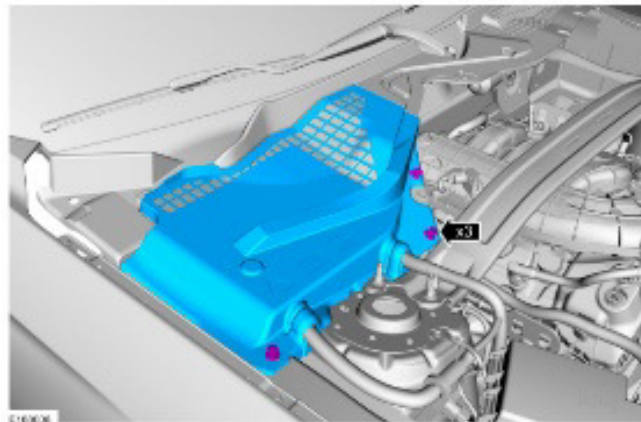

2. Loosen the nut and position the negative battery cable.
Torque: 44 lb.in (5 Nm)

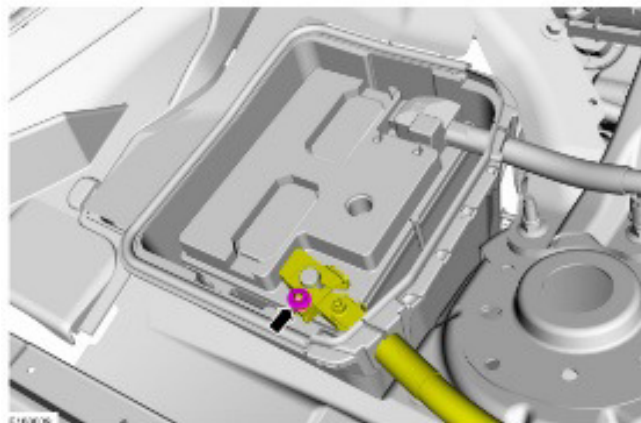



Part Number: M-20201-M/GT350
Part Description: Mustang Strut Tower Brace Kit
INSTALLATION INSTRUCTIONS

NO PART OF THIS DOCUMENT MAY BE REPRODUCED WITHOUT PRIOR AGREEMENT AND WRITTEN PERMISSION OF FORD PERFORMANCE PARTS.

3. Position the positive battery cable cover, loosen the nut, and position the positive battery cable.
Torque: 44 lb.in (5 Nm)

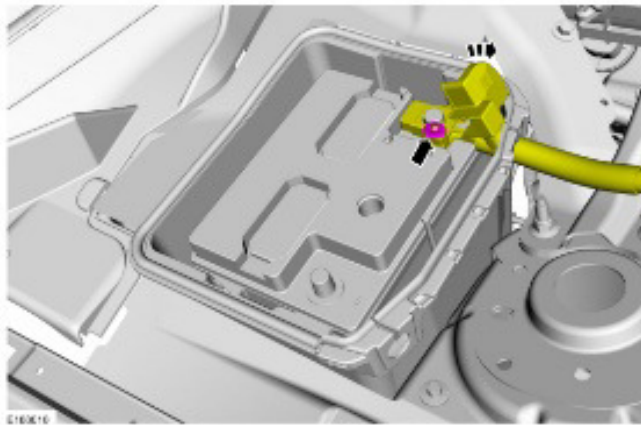

NO PART OF THIS DOCUMENT MAY BE REPRODUCED WITHOUT PRIOR AGREEMENT AND WRITTEN PERMISSION OF FORD PERFORMANCE PARTS.

Plastic Cowl Extension (if equipped)

Remove the retainers and the clips on the cowl panel grille.

1. Remove the seven (7) reusable retainers.
2. **Do not** depress and remove the 2 clips.

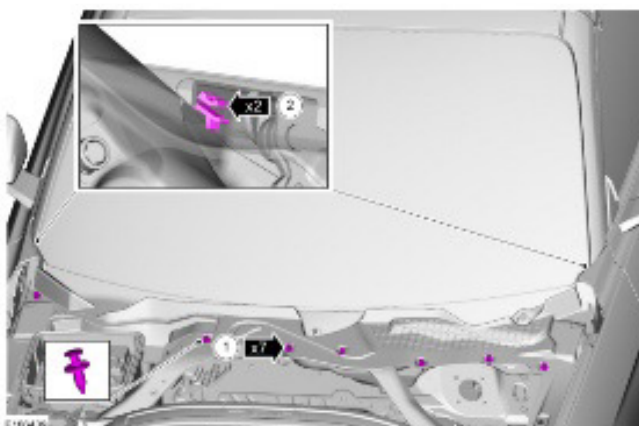

3. Lift cowl panel grille enough to access (2) bolts that retain plastic cowl extension. Wiper arms do not have to be removed.



4. Remove the remaining two (2) bolts and two (2) nuts that are not under the cowl panel grille
5. Remove plastic cowl extension.

NO PART OF THIS DOCUMENT MAY BE REPRODUCED WITHOUT PRIOR AGREEMENT AND WRITTEN PERMISSION OF FORD PERFORMANCE PARTS.

Strut Tower Cross Brace Removal – If Equipped

1. Detach the wiring harness retainer.
2. Remove the nuts and the strut tower cross brace.

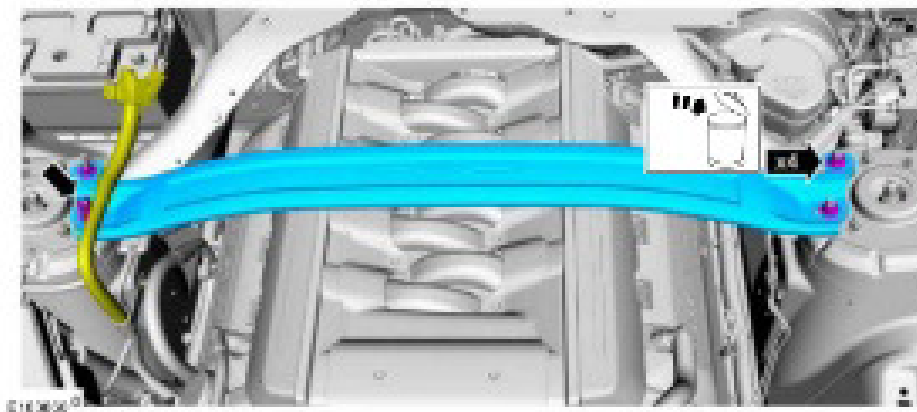

Strut Tower Cross Brace and Steel Cowl Extension installation

1. Lift the cowl panel to install the steel cowl extension. Reuse the original fasteners. Apply blue thread locking compound to the threads. Install all 4 bolts before tightening. This step only applies if car was equipped with plastic cowl extension or you are replacing the factory steel cowl extension.

Torque: 26 lb.ft (35 Nm)

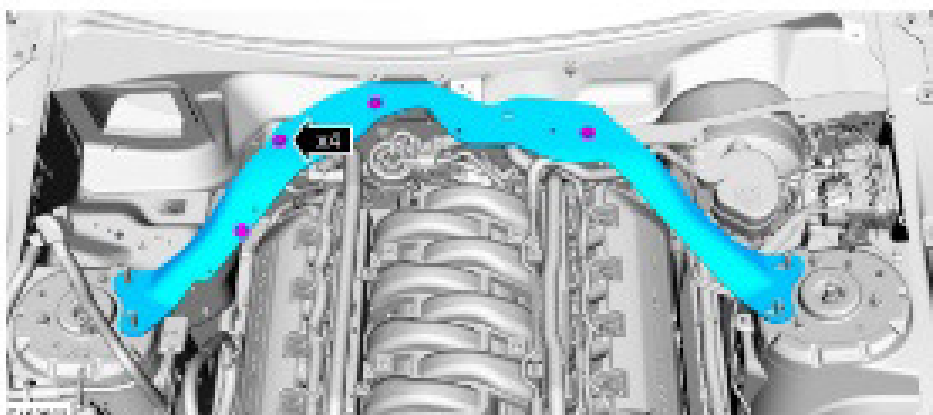

NO PART OF THIS DOCUMENT MAY BE REPRODUCED WITHOUT PRIOR AGREEMENT AND WRITTEN PERMISSION OF FORD PERFORMANCE PARTS.

2. Install the new strut tower cross brace with 4 new nuts.
Torque: 41 lb.ft (55 Nm)
3. Attach the wiring harness retainer.

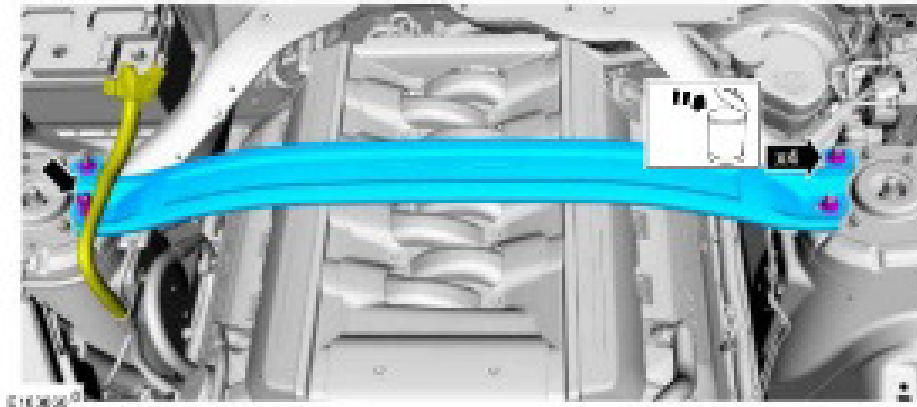

Installation of Cowl Panel Grille

1. To install, reverse the removal procedure from earlier in the instructions. This step only applies if vehicle was equipped with plastic cowl extension or if you replaced the steel cowl extension.

Battery Connect

Connect

1. To connect, reverse the disconnect procedure from earlier in the instructions.

NOTE: *When the battery is disconnected and connected, some abnormal drive symptoms may occur while the vehicle relearns its adaptive strategy. The vehicle may need to be driven to allow the PCM to relearn the adaptive strategy values.*