



11152 FLOWTECH I STANDARD HEADERS 31152 FLOWTECH II CERAMIC HEADERS

1978-87 Oldsmobile 442, Cutlass, & Vista Cruiser (260-403)

NOTE: Must modify stock exhaust to retain catalytic converters.

NOTE: Applications with oxygen sensor, use reducer #10105FLT for 2 1/2" 3-bolt flange or 10110FLT for 3" 3-bolt flange.

We realize that you had many choices when you chose your headers, and we thank you for choosing ours. At FLOWTECH® we put many years of performance exhaust experience into every product we build. We feel and know you'll agree that FLOWTECH® Headers are the best you can buy at any price.

As a result of the restricted room available in some engine compartments, you may experience a close fit to some body and chassis components. This is a normal condition. If this is your first time installing a set of headers, it may be time consuming. While not complex, stick with it. As soon as you start your engine, the reward of additional horsepower and performance will be well worth your efforts. Proper installation and periodic maintenance will result in the maximum performance and life from your FLOWTECH® Headers.

READ THESE INSTRUCTIONS CAREFULLY BEFORE STARTING:

For the ease of installation, your vehicle must be raised a minimum of 36".

Warning: Should you decide to install any exhaust product yourself, be warned that the original equipment jack that came with the vehicle is intended for emergency use only. The use of a frame jack, in conjunction with a floor jack, as the main support is highly recommended to minimize the accidental dropping of a vehicle while the installation proceeds. Never go under a vehicle that is supported by only a bumper jack!

A. PREPARE THE VEHICLE FOR INSTALLATION:

1. Disconnect the battery to prevent accidental damage to the electrical system.
2. Remove the stock exhaust manifolds. Remove the headpipe back to the catalytic converter inlet.
3. Remove the clutch idler assembly, if so equipped.
4. Remove the starter motor brace.

NOTE: Because of limited clearance, the starter motor brace will not be used.

5. Remove the oil filter and oil filter housing.
6. Disconnect the front driveshaft at the universal joint.

B. CHECK THE CONDITION OF THE ENGINE MOUNTS:

INSTALLATION NOTE: It is recommended that new engine mounts be installed before installing the headers.

C. LEFT SIDE HEADER INSTALLATION:

1. Bend the motor mount heat shield down around the back side of the motor mount.
2. Because of limited clearance, remove the starter heat shield.
3. If the vehicle has an alternator mounted on the left side of the engine, it will be necessary to notch the header flange for clearance. See Figure A.

4. Starting from below, place the header into position over the exhaust ports. Do not start the bolts at this time.
5. Reinstall the starter with the header still loose.
6. Place the gasket into position. Install the front and rear header bolts, but do not tighten at this time.
7. Install the balance of the bolts. Tighten all the bolts progressively and evenly until they are tight.

- NOTE:** If you wish to retain the stock heat stove, it will need to be modified (Fig. B). Reinstall it using the two stock flat washers as spacers for the stock bolts (Fig. C).
8. Reinstall the oil dipstick and clutch idler assembly, if required.

D. RIGHT SIDE HEADER INSTALLATION:

1. Bend the motor mount heat shield down around the back side of the motor mount.
 2. Relocate the fuel line to the back right hand side of the crossmember.
 3. Starting from below, place the header into position over the exhaust ports. Install the rear section of the header. Do not start the bolts at this time.
 4. Place the gasket into position. Attach the rear section of the header to the cylinder head. Do not start the bolts at this time.
 5. Reinstall the oil filter housing (we recommend using a new gasket) and oil filter.
- NOTE:** Use an AC® PF-30 short housing oil filter, instead of the original filter to provide ample clearance.
6. Install the balance of the bolts. Tighten all the header bolts progressively and evenly until they are tight.

E. AFTER HEADERS ARE IN PLACE:

1. Inspect all points with limited clearance. Relocate any points that have direct contact with the headers. Make sure there is adequate clearance around all lines (transmission, brake, fuel, and electrical wires). Reroute as necessary. REPLACE ANY FLUIDS THAT YOU MAY HAVE REMOVED OR LOST.
2. Reconnect the battery cable.

F. CONNECT THE EXHAUST SYSTEM:

1. Bolt the reducers and gaskets to the header collectors.
2. Attach the exhaust system by either welding or clamping the exhaust pipes to the reducer adapters.

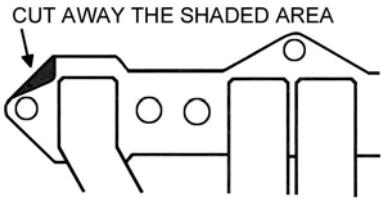

Figure A

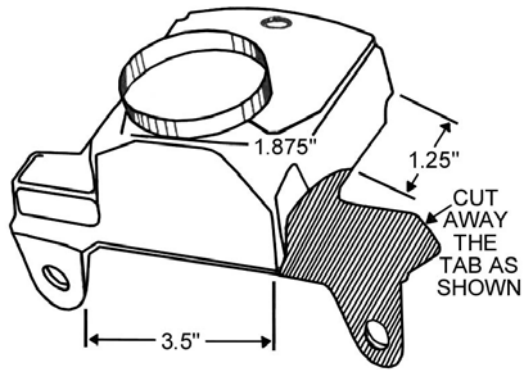

Figure B

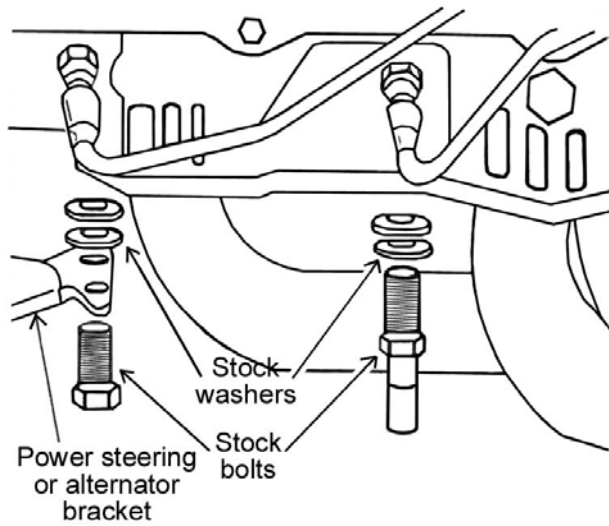

Figure C

FLOW TECH
by **Holley**