



11530FLT (Black) & 31530FLT (Ceramic) Full Length Headers

2WD - 1968-87 1/2, 3/4, and 1 ton Trucks, 1968-87 Blazer/Jimmy, 1973-91 Suburban (396-454)

4WD - 1968-81 1/2 & 3/4 ton Pickup, 1973-81 Blazer/Jimmy K5, & 1973-81 Suburban (396-454)

NOTE: Must modify stock exhaust to retain catalytic converters.

NOTE: Applications with oxygen sensors will use reducer 10105FLT for 2 1/2" 3-bolt flange or 10110FLT for 3" 3-bolt flange.

NOTE: Must use original factory Big Block engine frame mounts and hardware.

Thank you for making FLOWTECH HEADERS your choice in a high-performance exhaust system. At FLOWTECH, we put many years of performance exhaust experience into every product we build. We feel and know you will agree that FLOWTECH HEADERS are the best you can buy at any price.

As a result of the restricted room available in some engine compartments, you may experience a close fit to some body and chassis components. This is normal. If this is your first time installing a set of headers, it may be time consuming. While not complex, stick with it. As soon as you start your engine, the reward of additional horsepower and performance will be well worth your efforts. Proper installation and periodic maintenance will result in maximum performance and life from your FLOWTECH HEADERS.

WARNING! Breaking in an engine with ceramic-coated headers WILL result in damage to the coating and will VOID all warranties. Ceramic-coated headers require several heat cycles to fully cure before they will withstand extreme heat. FLOWTECH recommends using a cast-iron exhaust manifold or an old header to break in new engines to avoid coating damage.

BEFORE STARTING

For the ease of installation, your vehicle must be raised a minimum of 36". **WARNING!** Should you decide to install any exhaust product yourself, be warned that the original equipment jack is intended for emergency use only. The use of a frame jack, in conjunction with a floor jack as the main support, is highly recommended to minimize the accidental dropping of a vehicle while the installation proceeds. Never go under any vehicle that is only supported by a bumper jack.

INSTALLATION PROCEDURE – PLEASE READ CAREFULLY

1. Disconnect the battery to prevent accidental damage to the electrical system.
2. Unbolt the headpipe from the stock exhaust manifold and move aside. Remove the stock exhaust manifold.
3. Remove the spark plugs and clutch linkage (if equipped).

NOTE: The clutch linkage should not be removed on late model trucks with linkage mounted to the bellhousing.

NOTE: Motorhomes, equipped with automatic transmissions, must remove the shift rod from the transmission.

NOTE: It is recommended that new engine mounts be installed before installing headers.

LEFT SIDE HEADER INSTALLATION:

1. Starting from below, work the header up through the chassis into position.
2. Cut 5-16" off of one end of the stock spark plug heat shields (**Figure A**).
3. Position the spark plug heat shields and the header gasket. Start all bolts.
4. Tighten all bolts (most restricted first).
5. Replace the spark plugs, clutch linkage, and shift linkage (if removed).

NOTE: On all 1973-75 models equipped with the air conditioning compressor mounted on the left (driver's) side of the engine, it will be necessary to modify the mounting bracket (**Figure B**).

NOTE: On 1968 power steering equipped vehicles, it will be necessary to fabricate and install a spacer (**Figure C**).

RIGHT SIDE HEADER INSTALLATION:

1. Remove the stock exhaust manifold, spark plugs, and dipstick tube.
2. Starting from below, work the header through the chassis into position.
3. Cut 5-16" off of one end of the stock spark plug heat shields (**Figure A**).
4. Position the spark plug heat shields and the header gasket. Start all bolts.
5. Tighten all bolts (most restricted first).
6. Replace the spark plugs and dipstick tube.

NOTE: On all 1969-72 vehicles with factory air conditioning mounted on the right (passenger's) side of the engine, it will be necessary to modify the mounting bracket (**Figure D**).

NOTE: On all 1968-72 vehicles equipped with factory air conditioning, it will be necessary to fabricate and install a spacer under the A/c mounting bracket (**Figure E**).

7. Inspect all points with limited clearance. Relocate any points that have direct contact with the headers. Make sure there is adequate clearance around all lines (transmission, brake, fuel, and electrical wires). Reroute, as necessary. **Replace any fluids that you may have removed or lost.**
8. Connect the battery, start the engine, and check for leaks.
9. When you have finished installing your FLOWTECH HEADERS, take the vehicle for a road test. Listen carefully for any exhaust leaks or other strange noises and make corrections. When the vehicle has been driven a few days, retighten the header bolts.

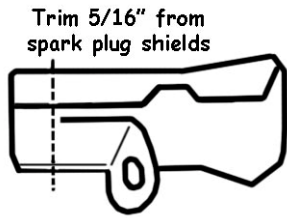

Figure A

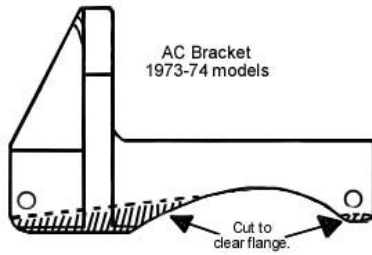

Figure B

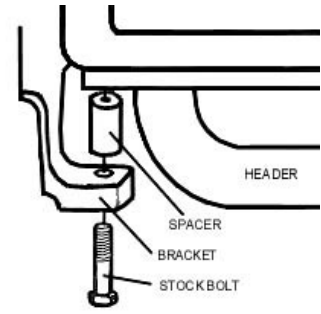

Figure C

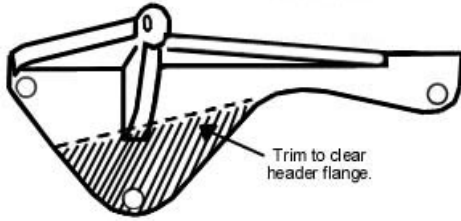

Figure D

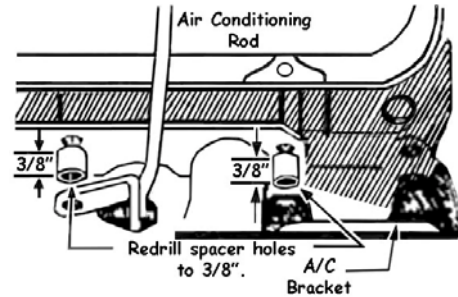

Figure E