



Installation Instructions

817938

**1967-72 FORD F100, 250 & 350
5.0L, 5.8L, 5.9L & 6.4L ENGINE
2WD, 115" & 131" Wheelbase
Short/Long Bed**

For trucks without factory auxiliary fuel tank.

OVERVIEW:

1. Take a moment to read and understand these instructions before installing your Flowmaster performance system.

NOTE: Please inventory all parts now before continuing and if necessary, report any missing items to our tech line. This will avoid potentially stranding your vehicle until any missing replacement parts arrive.

ITM #	PART #	DESCRIPTION	QTY.
8	86632S	R/L Side Exit Pipe	2
9	86664S	Left Dump Exit Pipe	2
10	86665S	Right Dump Exit Pipe	2
N/A	PK1034	Hardware Package includes:	1
11	MC250BS	2½" Stainless Band Clamp	8
12	MC200BS	2" Stainless Band Clamp	1
13	HA572	Rear Hanger	2
14	HA602	Front Hanger	4
15	HW204	⅝"-18 x 1 Bolt	8
16	HW102	⅝" Nut	8
17	HW302	⅝" Flat Washer	16
18	HW308	⅝" Lock Washer	8
19	HW501	⅜" Hanger Keeper	4

ITM #	PART #	DESCRIPTION	QTY.
1	86652S	R/L Inlet Pipe	2
2	86653S	Right H-Pipe	1
3	86654S	Left H-Pipe	1
4	842546-Z	Muffler	2
5	86647S	Right Tailpipe	1
6	86648S	Left Tailpipe	1
7	86649S	R/L Rear Exit Pipe	2

PREPARE VEHICLE FOR KIT INSTALLATION:

2. Raise vehicle up on a hoist or rack to working height. If you don't have access to a hoist or rack, support vehicle with jack stands.

WARNING:
Avoid serious burns! Allow your vehicle time to cool completely before touching any factory engine components.

To ease preparation and installation of your new kit:

- Apply penetrating lubricant to mounts, bolts and clamps before you remove them.
- Use stands as necessary to support parts as you detach them from your vehicle and again as you install new parts.

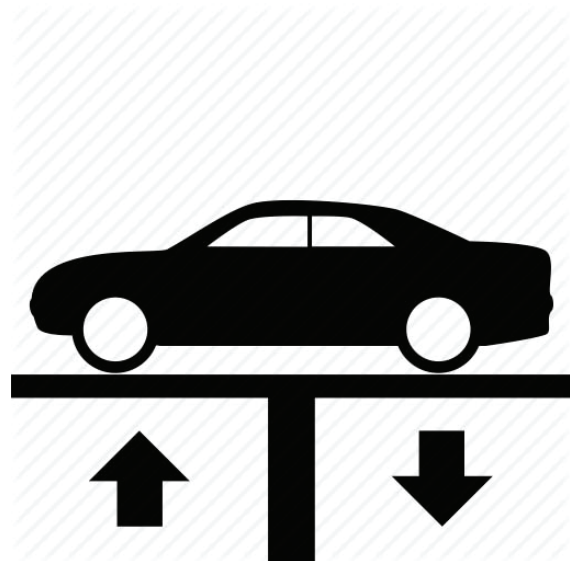

3. Remove existing system from header collector or manifold down pipes rearward.

INSTALL FLOWMASTER EXHAUST SYSTEM:

4. Remove nuts from Flowmaster clamps, apply anti-seize compound to bolts and re-install nuts.



5. Mark forward cross member on both sides, inboard 2½" from intersecting frame edge.

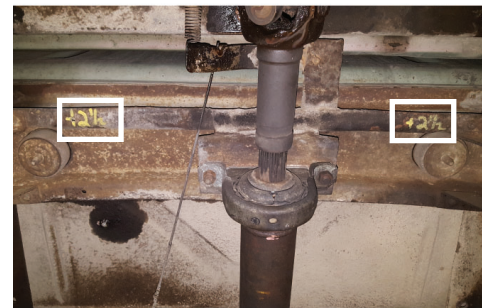
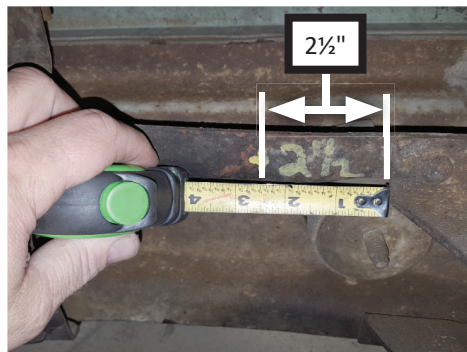
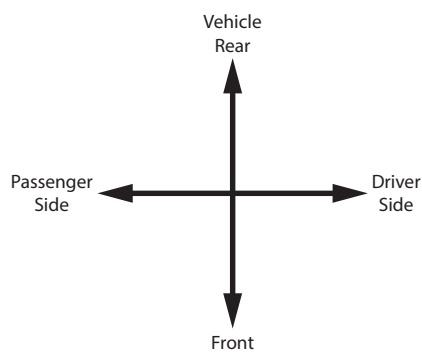

6. Use (x2) **rear frame hangers (14)** (oriented flanges out) to drill ⅝" mount holes then install hangers with (x2) **bolts (15)**, (x4) **flat washers (17)**, (x2) **lock washers (18)** and (x2) **nuts (16)**.

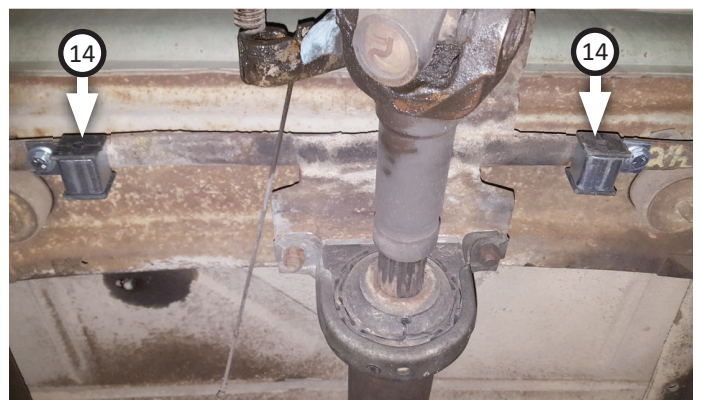

7. Mark rear cross member on both sides, inboard 4" from intersecting frame edge. Use (x2) **rear hangers (13)** oriented as shown to center then drill mount holes.



NOTE: For short bed vehicles only, trim 16" from rear of H-pipe for proper fit.

8. Assemble **left (3)** and **right (2)** H-pipe together with **clamp (12)**, then hang assembly into rear frame hangers (installed step 6) on forward cross member.

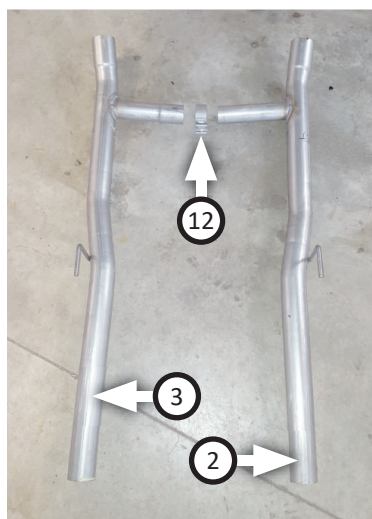

9. Place (x2 ea.) **clamps (11)** onto **mufflers (4)** then connect them to h-pipes and tighten clamps enough to allow for later adjustment.

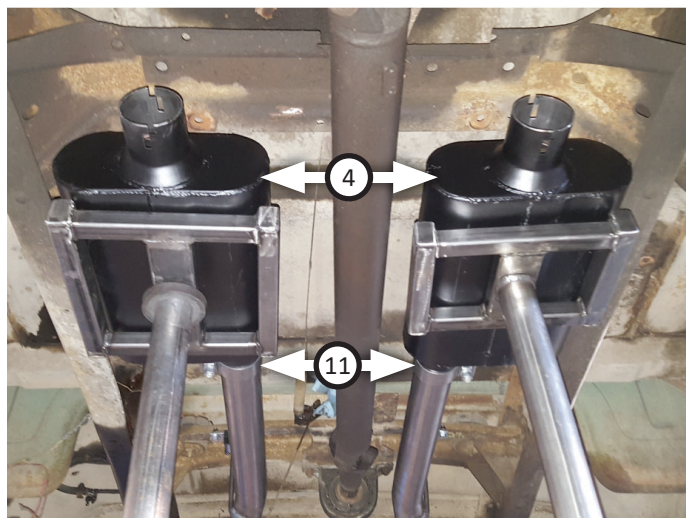

NOTE: Passenger side of frame has a pre-existing hole that simply needs to be enlarged to $\frac{5}{16}$ ".

10. Drill (x2) $\frac{5}{16}$ " holes in cross member above mufflers, placing **front hangers (14)** against frame edges as shown to locate them properly.

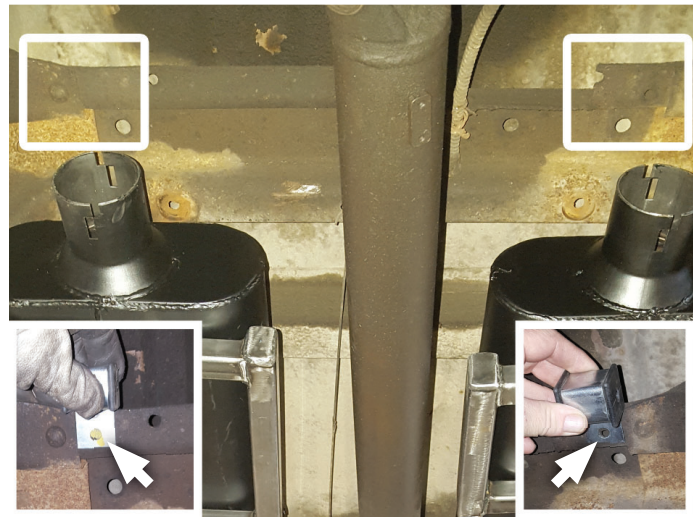

11. Set (x2) **clamps (11)** onto muffler outlets. Place (x2) rear hangers onto **right (5)** and **left (6)** tailpipes.

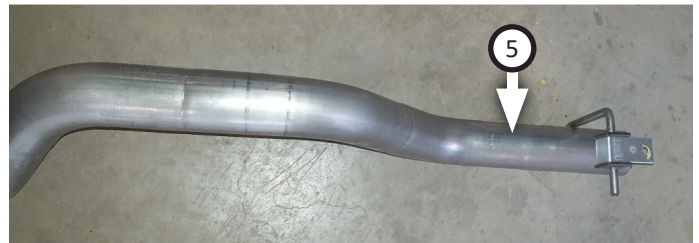
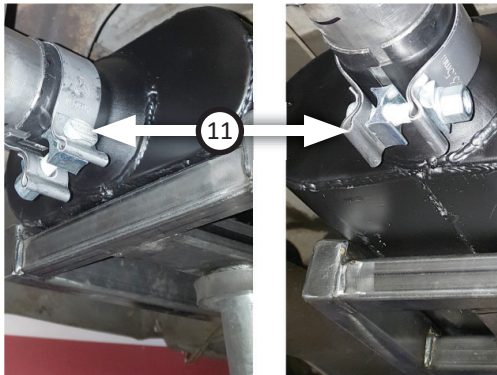

12. Fasten (x2) hangers to rear crossmember (step 7) with (x4) **bolts (15)**, (x8) **flat washers (17)**, (x4) **lock washers (18)** and (x4) **nuts (16)**. Connect left and right tailpipes to mufflers.



13. Secure (x2) front hangers (on tailpipes) to crossmember (step 10) with (x2) **bolts (15)**, (x4) **flat washers (17)**, (x2) **lock washers (18)** and (x2) **nuts (16)**.

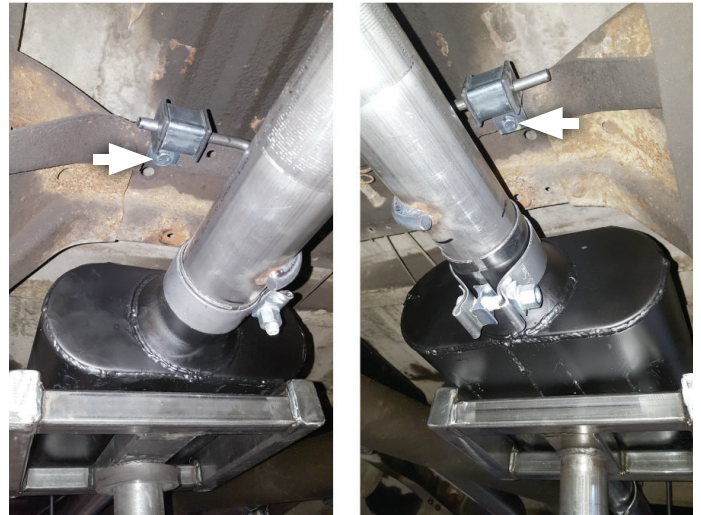

NOTE: Additional fabrication may be necessary for inlet pipes to fit your vehicle.

14. Use **right and left inlet pipes (1)**, to connect factory exhaust and h-pipes, using (x2) **clamps (11)** to secure connections.

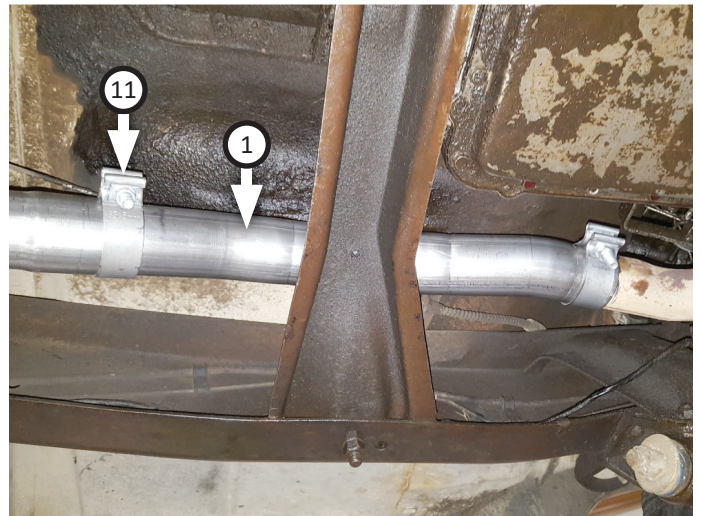

NOTE: This kit includes **rear (7)**, **side (8)** and **dump (9, 10)** exit pipes. The exit pipes are left long in order to let you decide how your exhaust should look. Choose which style you would prefer, then use corresponding parts to complete this step.

15. Place (x2) **clamps (11)** onto exit pipes and connect them to left and right tailpipes. Rotate exit pipes to desired distance from body or bumper, so they are properly positioned.

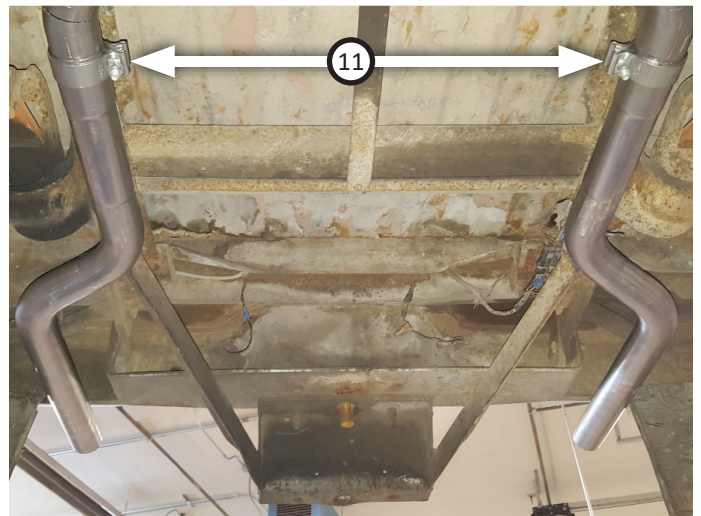

16. Adjust exhaust components for fit; maintaining ½" clearance and compensating for suspension, travel and vibration, then tighten all clamps. Finally, fit (x4) **hanger keepers (19)** onto each sideways hanger.
17. Recommended: Secure slip-fit connections with a 1-inch tack weld then spray high-temp paint over each weld to prevent rust and premature corrosion.



Congratulations, the installation of your FLOWMASTER performance exhaust system is now complete!





Installation Diagram

817938

1967-72 FORD F100, 250 & 350

5.0L, 5.8L, 5.9L & 6.4L ENGINE

2WD, 115" & 131" Wheelbase

Short/Long Bed

For trucks without factory auxiliary fuel tank.

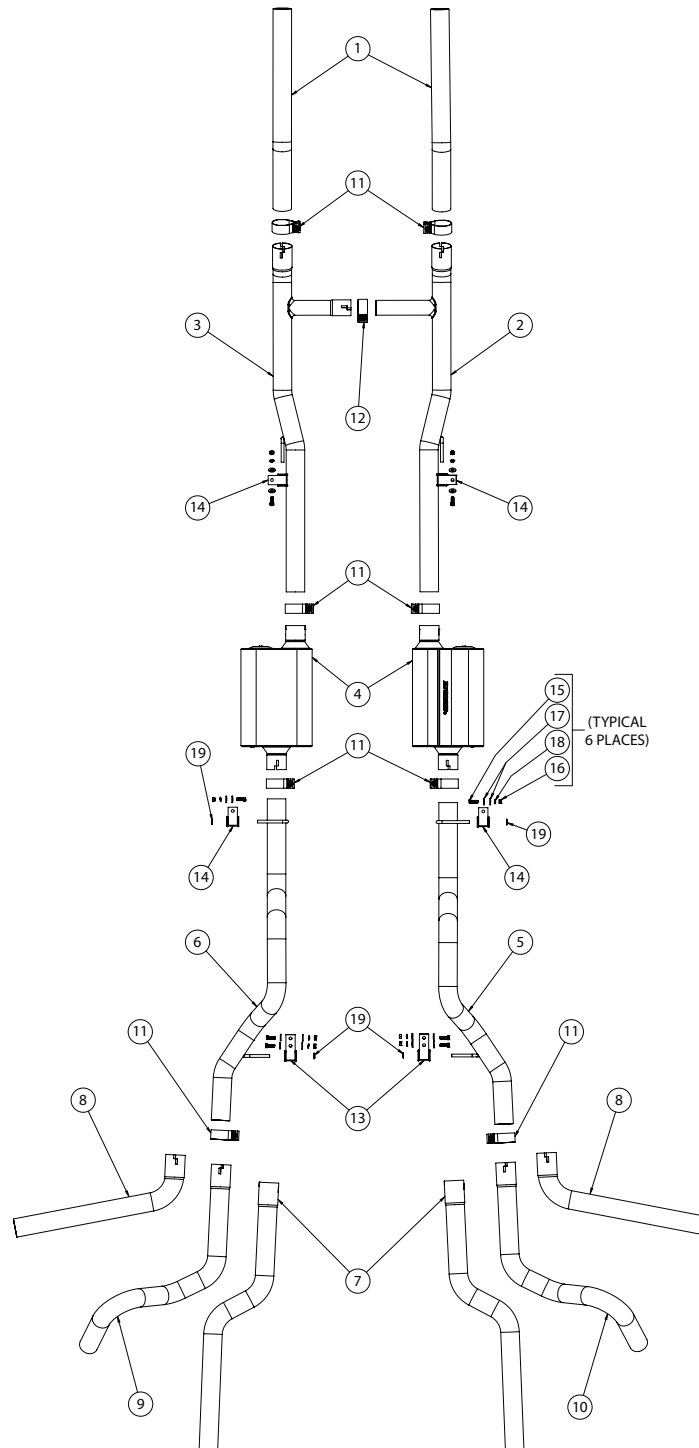

Learn more about performance exhaust systems we have.