



409SS® Stainless Steel

Installation Instructions for:

SYSTEM #817819

2018 Jeep Wrangler JL, 2- &
4-door models with 3.6L Engine

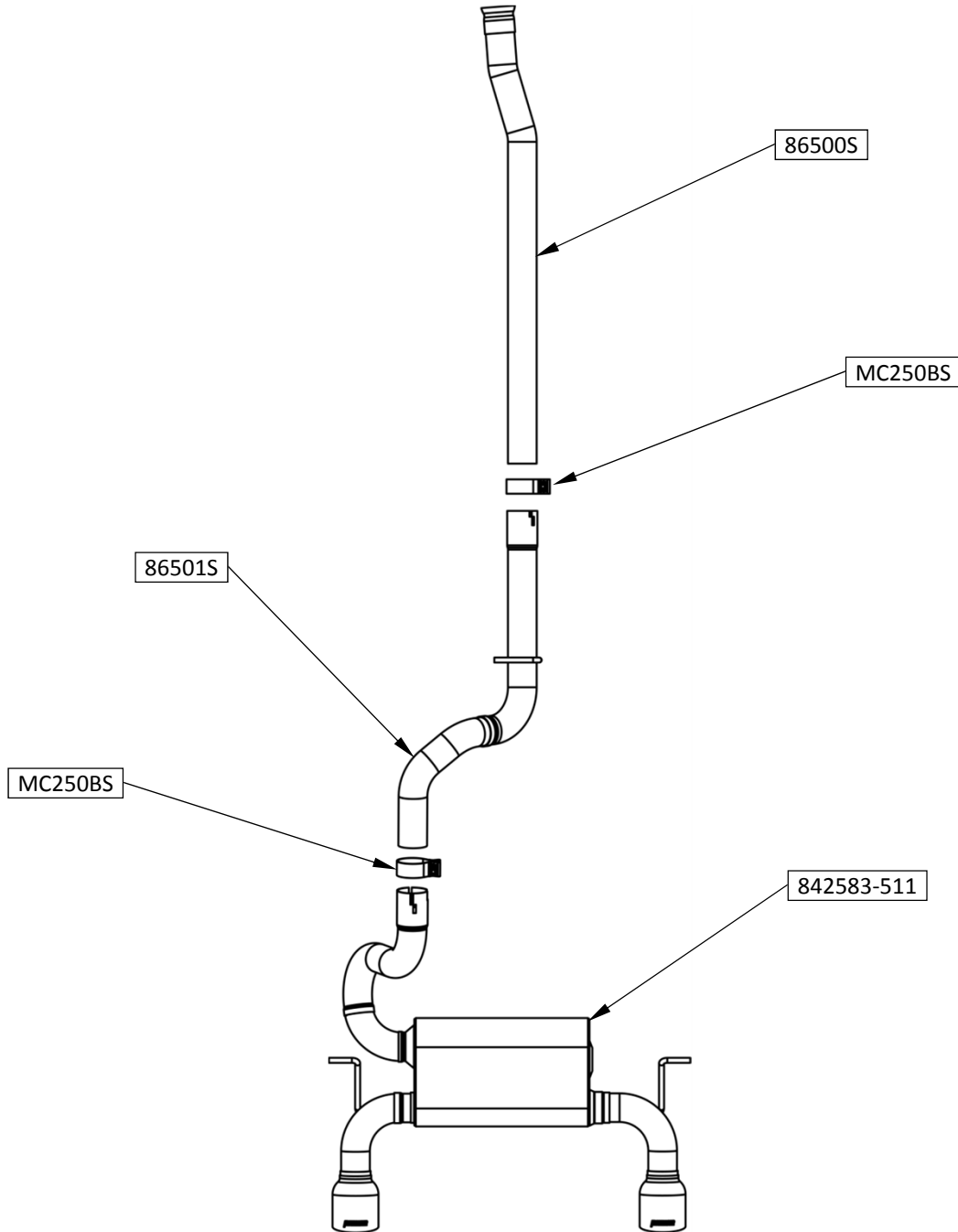

REVIEW THE INSTRUCTIONS AND VERIFY THE KIT CONTENTS:

1. Please take a moment to read and understand these instructions before installing your Flowmaster performance exhaust system.



2. Use the system drawing (front page) and parts list (below) to verify your kit's contents. In the unlikely event that any parts are missing, please contact FLOWMASTER Technical Support for replacement.

PART NO.	DESCRIPTION	QTY.
86500S	FRONT PIPE	1
86501S	REAR PIPE	1
842583-511	MUFFLER	1
PK959	PARTS KIT:	1
MC250BS	• 2-1/2" BAND CLAMP	2
HW502	• 7/16" HANGER KEEPER	3

REMOVE THE FACTORY EXHAUST SYSTEM:

WARNING

Avoid serious burns! Allow the exhaust system to cool completely before removing the factory exhaust system.

3. Raise the vehicle and support it securely with jack stands. To ease the removal of the factory exhaust system, spray a penetrating lubricant onto all rubber hangers and clamped connections that will be disassembled.



4. Support the muffler with a stand, then loosen the clamp at the muffler inlet connection above the rear axle.



5. At the left and right rear mounts supporting the muffler, remove the lower bolt on each mount.



6. Remove each mount's upper bolt. Carefully lower the stand and slide the muffler off of the inlet pipe to remove it from the vehicle.



7. Lay the factory and Flowmaster mufflers next to each other, with their inlet pipes pointing the same direction. Then transfer the hanger mounts from the factory muffler to the Flowmaster muffler.



8. Loosen the clamp at the front of the factory midpipe-resonator assembly. Disconnect the hanger on the pipe from the rubber mount on the vehicle and slide the assembly rearward to clear the front cross member, then forward and down to remove it from the vehicle.

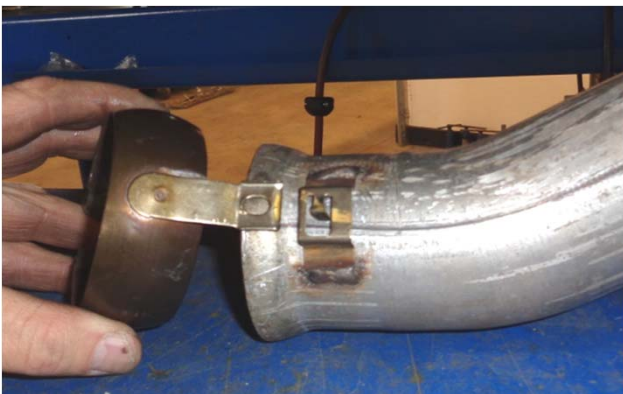

9. Use a screwdriver to release the tab holding the clamp on the midpipe, and remove the clamp. Remove the nuts from the factory and Flowmaster clamps, apply anti-seize compound to the bolts, and reinstall the nuts.

INSTALL YOUR FLOWMASTER EXHAUST SYSTEM:

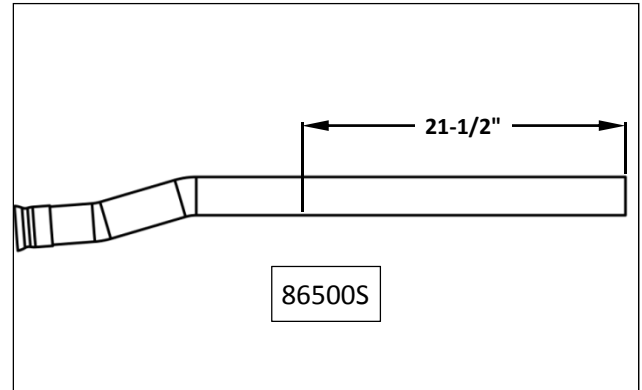

10. **FOR TWO-DOOR VEHICLES ONLY**, cut 21-1/2" off the rear end of **front pipe 86500S**.



11. Slip the factory clamp over the ball end of the factory pipe, mate the front end of **front pipe 86500S** to it, then snug the clamp just enough to still allow adjustment. Rotate the pipe so that it is level and parallel to the vehicle frame.



12. Slip a **clamp MC250BS** over the front end of **rear pipe 86501S**, then slide the pipe over the rear of the front pipe while pushing the pipe's hanger into the rubber mount on the vehicle. Snug the clamp just enough to still allow adjustment.



13. Slip a **clamp MC250BS** over the inlet of **muffler 842583-511**. Slide the muffler inlet over the rear of the rear pipe. Support the muffler with a stand, then ensure all pipes are completely seated.



14. Put the factory hanger mounts into position, then reinstall and tighten the factory bolts.
15. Adjust the position of the muffler and pipes to provide a satisfactory fit. Maintain a minimum of 1/2" clearance around all components of the exhaust system, keeping in mind suspension travel and vibration. After making any required adjustments, securely tighten the clamps.
16. After all clamps are tightened, slide a **hanger keeper HW502** onto the end of each muffler and pipe hanger, to prevent the hangers from slipping out of the rubber mounts.

Congratulations, the installation of your FLOWMASTER performance exhaust system is now complete!

