



OUTLAW
S E R I E S

409S. Stainless Steel

Installation Instructions for:
SYSTEM #817740
2015-2017 DODGE CHALLENGER
R/T SCAT PACK, SRT 392 & SRT HELLCAT
6.2L / 6.4L · V8 HEMI ENGINE

Removal:

- 1) Raise the vehicle and support securely with stands. To ease the removal of the stock system, spray a penetrating lubricant onto the rubber hangers as well as the two clamped connections at the center of the vehicle.
- 2) Place a stand under the rear of each tailpipe to support the rear of the system. Just forward of the rear differential, you will find two exhaust valve actuators, one mounted to the side of each tailpipe. Unplug the wire from the actuator and tuck away for reconnection later. Slide the two hangers (3 on SRT 392) on each tailpipe out of the rubber mounts on the vehicle. Unclip the grounding strap from the rear hanger on the right side of the vehicle. Then using a 15mm socket, loosen the clamps at the slip fit connections behind the catalytic converters. Carefully lower the stands at the rear of the vehicle and with the help of an assistant slide the system back off of the head pipes and lower the system from the vehicle.

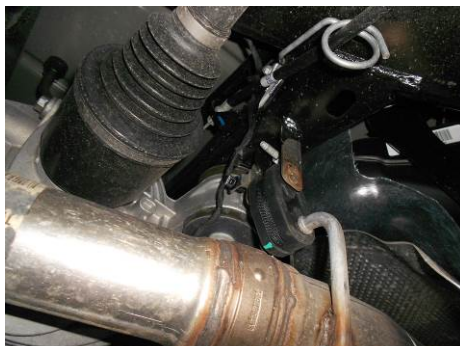

- 3) Once the factory system is out of the vehicle, use a 5/16" wrench to remove the three nuts securing the actuator to the mounts on the tailpipes. Remove the actuator and spring from the mount on each tailpipe.



Special Note:

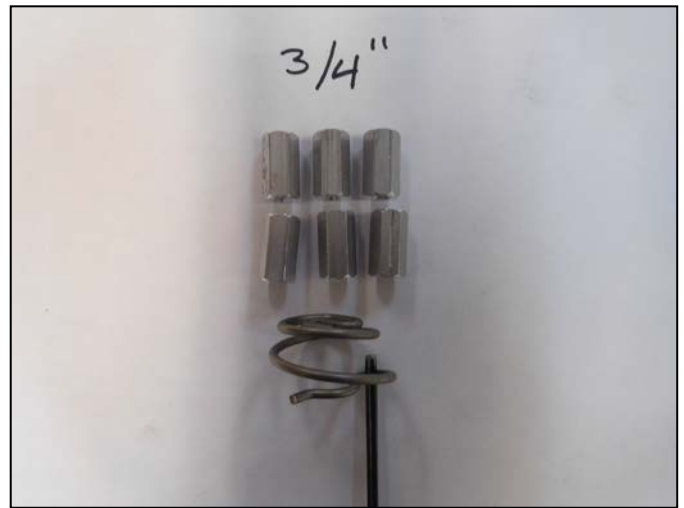
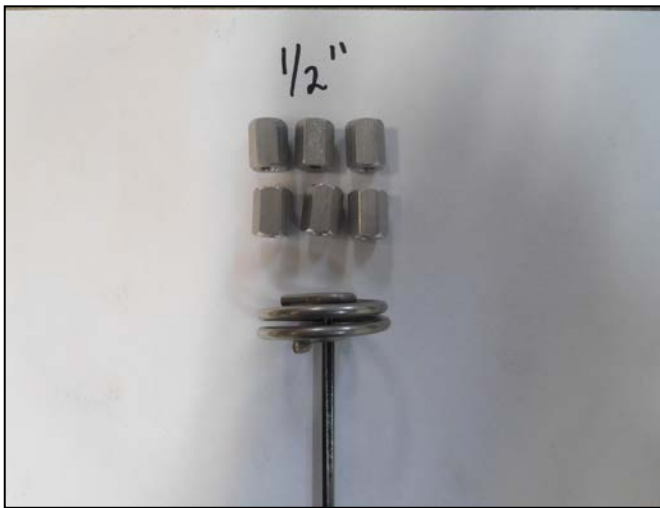

There are two possible spring designs on the actuator valve assemblies. Look at the photos above and determine which of the two possible springs that you have on your actuators. Depending on which spring you have, either the taller spring on the right or the flatter on the left, you will use the size of standoff included in the parts kit shown with the spring above.

Installation:

1) Take one of the new Flowmaster tailpipe assemblies and place it upside down on a flat surface, place something under the tip if needed to protect from scratches. Begin by placing one of the #10-32 x 3/8" Button Head Screws included in the parts kit through the top hole of the bracket welded to the tailpipe. Then follow with two of the included #10 flat washers. Then thread on one of the #10-32 x 1/2 or 3/4" Hex standoff spacers onto the screw and hand tighten. Repeat this step with the other two holes on this mount as well as the three holes of the mount on the other tailpipe.



2) Then mount with the spacers and washers attached. Tighten securely.

3) Place an included #10-32 x 3/4" Button Head Screw into the bottom hole of the actuator assembly followed by one #10 flat washer. Then place the actuator up to the mount on the tailpipe, the center arm of the actuator spring must be between the tabs on the mount. Rotate the assembly so that the actuator motor is vertical and until the spacers line up with the holes in the actuator. Thread the bolt on the actuator into the spacer on the tailpipe mount, leave this bolt loose and repeat this step on the other two holes of the actuator.



4) Be sure that the center arm of the actuator spring is between the bottom and top tabs of the mount, tighten all three bolts securely. Repeat the step on the other tailpipe assembly.



5) Begin the installation by placing a supplied 2-3/4" clamp onto each of the inlets of the Scavenger pipe **#26522S**. Then place the Scavenger pipe onto the back of the stock head pipes (the offset outlet pipe should be oriented to the right side). Level and center the assembly in the drive line tunnel and support with a stand. Tighten the two clamps enough to hold, but still allow for adjustment.



6) Place a supplied 3" clamp onto the inlet neck of both mufflers. Slide the mufflers onto the back of the Scavenger pipe assembly and support with stands. Level the mufflers and tighten the clamps enough to hold, but still allow for adjustment.



7) Place a supplied clamp onto the left muffler outlet. Place the left tailpipe **#26526S** into position and starting from the rear, connect the hangers on the tailpipe to the rubber mounts on the vehicle. Slide the tailpipe fully into the muffler outlet. Adjust the tailpipe so that the stainless tip is level and centered in the bumper cut-out. Tighten clamp enough to hold, but still allow for adjustment. Repeat this step for right tailpipe **#26527S**. **Note:** The middle hanger on SRT 392 models will not be used and can be removed if desired.



8) Reconnect the two electrical plugs removed in step 2 of the removal instructions back onto the tailpipe actuators now installed on the new Flowmaster tailpipes.

9) Adjust the position of the pipes, mufflers and tips to provide a satisfactory fit. A minimum of 1/2" clearance around all parts of the system must be maintained; while keeping suspension travel and vibration in mind. After adjustments have been made, you may now securely tighten all clamps.

10) After the system is secure, slide the 7/16" hanger keepers onto the ends of the hangers located at the front of each tailpipe. These will prevent the hangers from slipping out of the rubber mounts. Also reconnect the grounding clip to the rear hanger on the right side tailpipe.

11) For a more secure installation, we recommend welding all slip-fit connections.

PACKING LIST

<u>Qty</u>	<u>Description</u>	<u>Part#</u>
2	Mufflers	15430-253
1	Scavenger Assembly	26522S
1	Left Tailpipe Assembly	26526S
1	Right Tailpipe Assembly	26527S
1	Hardware Kit	PK799
2	2-3/4" Clamp	MC234BS
4	3" Clamp	MC300BS
2	7/16" Hanger Keepers	HW502
6	10-32 x 1/2 Hex Stand Off	HW512
6	10-32 x 3/4 Hex Stand Off	HW514
6	10-32 x 3/4" Button Head Screw	HW240
6	10-32 x 3/8" Button Head Screw	HW241
18	#10 Flat Washer	HW315



OUTLAW
S E R I E S
409S. Stainless Steel

Installation diagram for:
SYSTEM #817740
2015-2017 DODGE CHALLENGER
R/T SCAT PACK, SRT 392 & SRT HELLCAT
6.2L / 6.4L · V8 HEMI ENGINE

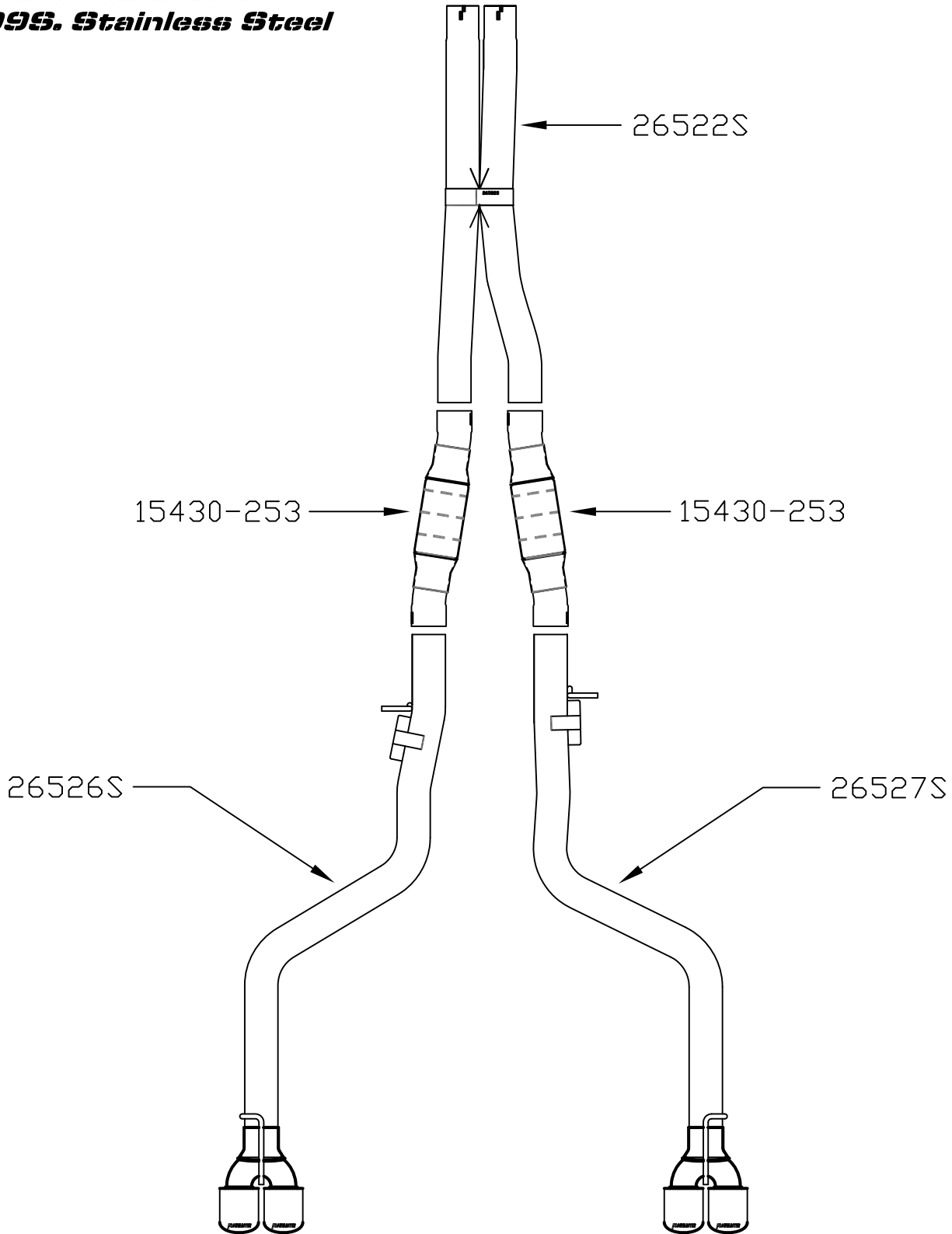

Feel the difference with Flowmaster.

Find out more about performance exhaust systems we have.