



FORCE II™

409S Stainless Steel

Installation Instructions for:
SYSTEM #817695
1968-1969 CHEVROLET CORVETTE
427 C.I. V8 ENGINES

Removal:

1) This system is designed to fit with Flowmaster manifold downpipe kits **81101** or **81103** or 2.50" pipe going from the manifolds to just behind the transmission cross member. Remove the existing exhaust system from the vehicle from this point back. Unbolt the factory hangers at the rear of the mufflers; these will not be used with the Flowmaster system.

Installation:



1) After installing either the **81101** or **81103** downpipe kits, place a provided 2.50" clamp onto the expanded ends of X-pipe assembly **86233S**, then slide onto the back of the manifold pipes, be sure that the pipes are fully slipped together. Place a stand under the rear of the assembly and tighten the clamps enough to hold, but still allow for adjustment. The Flowmaster embossed side of the assembly will be facing the ground.



2) Place a provided clamp onto both outlets of X-pipe assembly **86233S**. Place the expanded end of mid pipe **86241S** onto the right outlet of the X-pipe assembly. Rotate the pipe up into position and support the rear of the pipe with a stand. Tighten the clamp enough to hold, but still allow for adjustment. Repeat this step on the left side of the vehicle with pipe **86242S**.

3) Place one of the supplied **HA602** rubber mounts onto the wire hanger of right muffler assembly **842557-357**. Place a provided clamp onto the muffler inlet, then place the assembly onto the back of the mid pipe and slide the two fully together. Support the muffler with a stand. Using a supplied 3/8" bolt, nut, washer and lock washer, bolt the **HA602** hanger to the hole in the frame above the muffler outlet.



4) Place one of the supplied **HA602** rubber mounts onto the wire hanger of left muffler assembly **842557-356**. Place a provided clamp onto the muffler inlet, then place the assembly onto the back of the mid pipe and slide the two fully together. Support the muffler with a stand. Using a supplied 3/8" bolt, nut, washer and lock washer, bolt the **HA602** hanger to the hole in the frame above the muffler outlet.



5) Adjust the position of the pipes and mufflers to provide a satisfactory fit. A minimum of 3/4" clearance around all parts of the system must be maintained; while also keeping suspension travel and vibration in mind. Tighten all clamped connections down securely.

6) For a cleaner appearance and more secure installation, we highly recommend welding all slip-fit connections. If you live in a geographical area that has harsh winters or sees a great deal of precipitation, the use of high temperature paint over the welded areas can help to prevent surface rust and premature corrosion.

PACKING LIST

<u>Qty</u>	<u>Description</u>	<u>Part #</u>
1	X-Pipe Assembly	86233S
1	Right Mid Pipe	86241S
1	Left Mid Pipe	86242S
1	Left Muffler	842557-356
1	Right Muffler	842557-357
1	Parts kit	PK787
6	2 1/2" Clamp	MC250BS
2	Rubber Hanger	HA602
2	3/8" x 1" Bolt	HW208
2	3/8" Nut	HW103
2	3/8" Flat Washer	HW303
2	3/8" Lock Washer	HW309



Installation diagram for:
SYSTEM #817695
1968-1969 CHEVROLET CORVETTE
427 C.I. V8 ENGINES

FORCE II™

409S, Stainless Steel

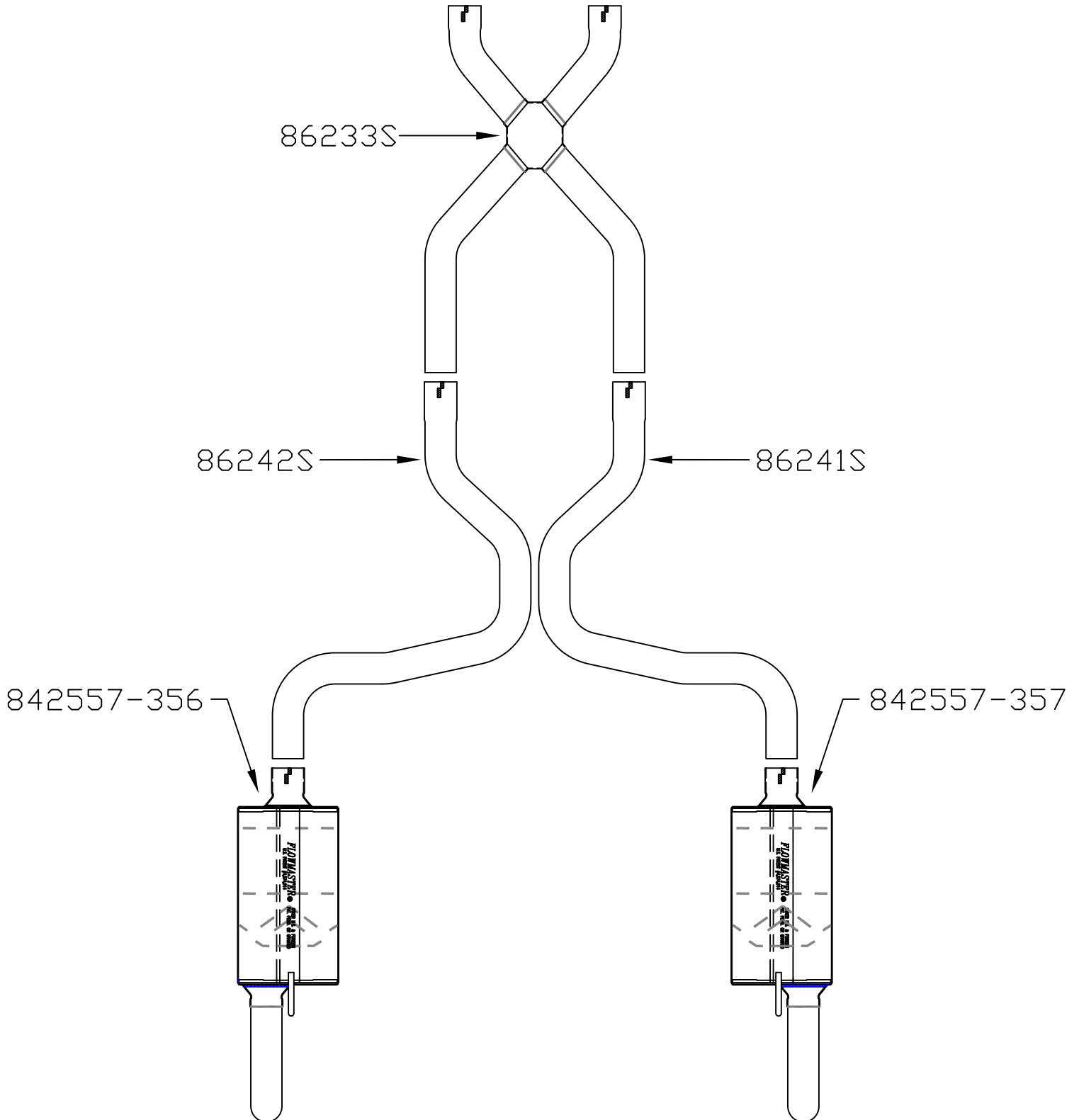

Feel the difference with Flowmaster.

Find out more about performance exhaust systems we have.