



Installation Instructions
717915
2019*-20 RAM 1500
5.7L HEMI ENGINE
2/4 Wheel Drive, All Wheelbases
 With Factory Single or Dual Tailpipes
 (*Does Not fit 2019 Classic Body)

OVERVIEW:

1. Take a moment to read and understand these instructions before installing your Flowmaster performance system.

NOTE: Please inventory all parts now before continuing and if necessary, report any missing items to our tech line. This will avoid potentially stranding your vehicle until any missing replacement parts arrive.

ITM #	PART #	DESCRIPTION	QTY.
5	EV701	Key FOB Controller Kit	1
6	EV704	Wire Assembly Controller Kit	1
7	MC300BS	3" Stainless Band Clamp	1
8	HW282	M6 x 1 x 12MM Bolt/Lock/Washer	2
9	HW283	M6 x 1 x 18MM Bolt/Lock/Washer	3
10	HW210	3/8"-16x1 1/2 Bolt	2
11	HW303	3/8" Flat Washer	4
12	HW309	3/8" Lock Washer	2
13	HW503	1/2" Hanger Keeper	3
14	HW120	18-8 Stainless Hex Nut	2
15	HW545	Nylon Cable Tie (Black)	10
16	HW547	7.5 Amp Micro Fuse	1
17	HW550	16 GA Red 20A Micro2 Fsd Crct Tap	1

ITM #	PART #	DESCRIPTION	QTY.
1	8430162-540	Direct Fit Muffler	1
N/A	PK1000	Hardware Pack includes:	1
2	EV208	Actuator Mount Assembly	1
3	EV501	Valve Spring	1
4	EV700	Actuator Motor	1

REMOVE STOCK EXHAUST SYSTEM:

2. Raise vehicle up on a hoist or rack to working height. If you don't have access to a hoist or rack, support vehicle with jack stands.

WARNING:
 Avoid serious burns! Allow your vehicle time to cool completely before touching any factory engine components.

To ease preparation and installation of your new kit:

- Apply penetrating lubricant to mounts, bolts and clamps before you remove them.
- Use stands as necessary to support parts as you detach them from your vehicle and again as you install new parts.

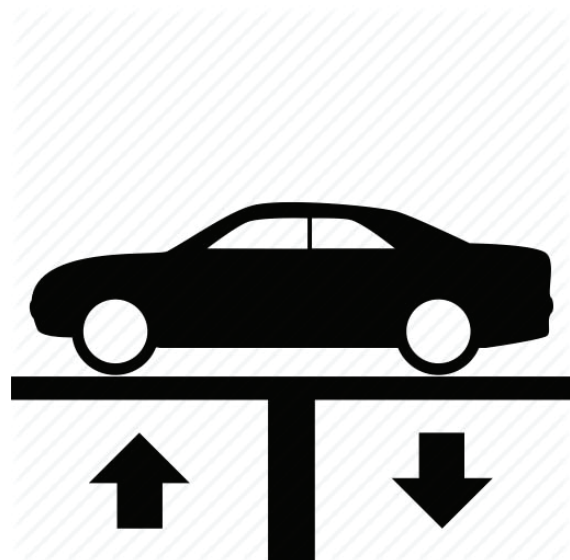

3. Cut exhaust pipe $\frac{1}{2}$ " behind back face of muffler.



4. Remove grounding wire from hanger and bolts (x2) securing muffler flange. Remove muffler section from vehicle and disassemble flange gasket. Retain gasket for later use.



INSTALL FLOWMASTER EXHAUST SYSTEM

5. Remove nuts from stock and Flowmaster clamps, apply anti-seize compound to bolts and re-install nuts.

NOTE: The image in this step is intended for illustrative purposes only and may or may not accurately reflect components included in your kit.



6. Place gasket flange (removed step 4) onto Flowmaster muffler (1).

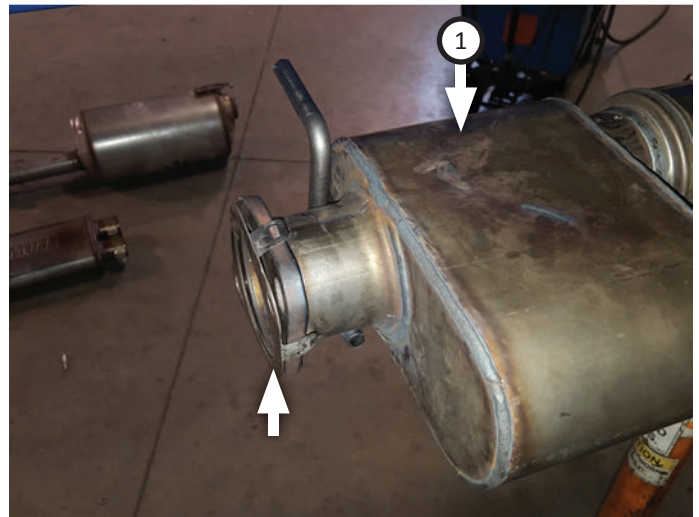

7. Fasten actuator mount assembly (2) onto muffler using bolt assemblies (x2) (8).

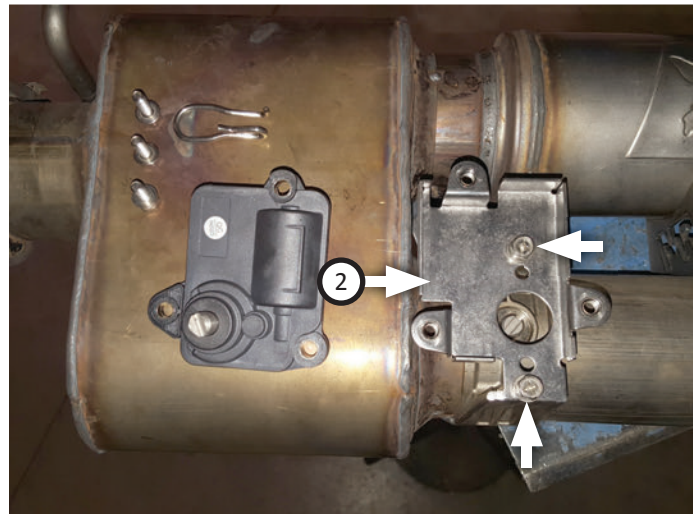

8. Place valve spring (3) into groove in muffler outlet then fasten actuator motor (4) onto mount ensuring valve spring lines up properly. Secure parts using bolt assemblies (x3) (9).

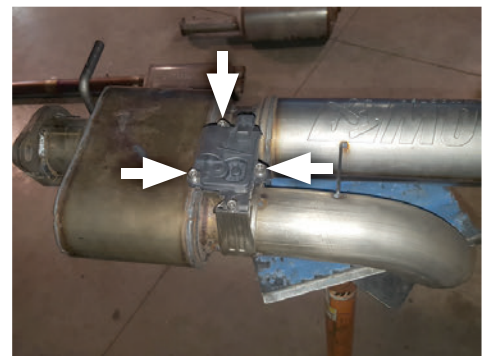
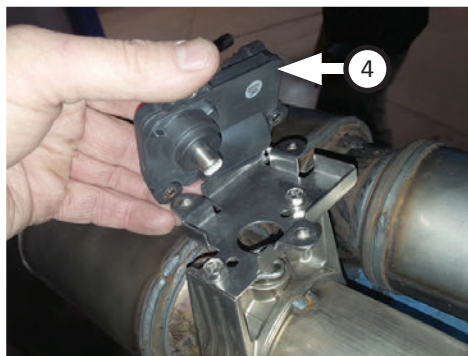
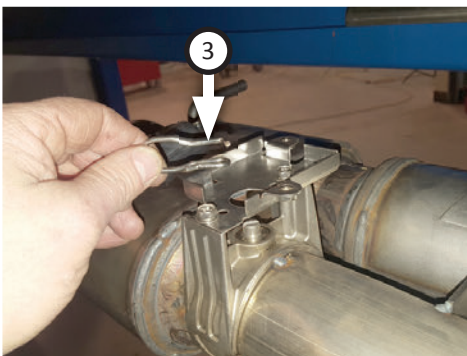

9. Fasten muffler flange to factory flange using **bolts (x2) (10)**, **flat washers (x4) (11)**, **lock washers (x2) (12)** and **nuts (x2) (14)**. Secure rear of muffler to exhaust using **clamp (7)**. Re-connect grounding wire.

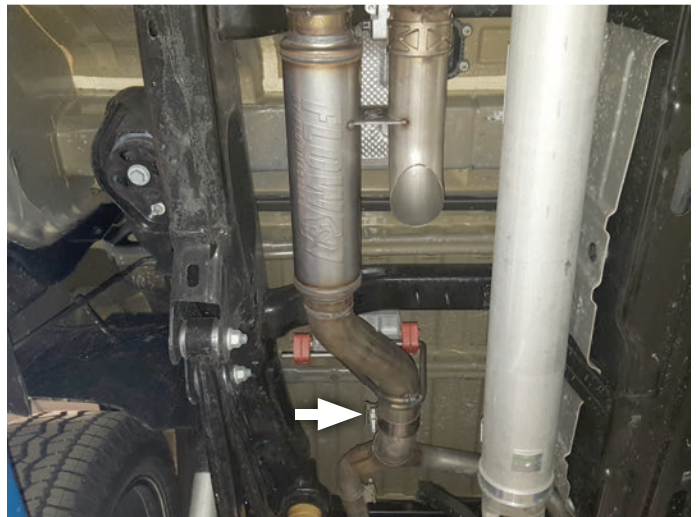
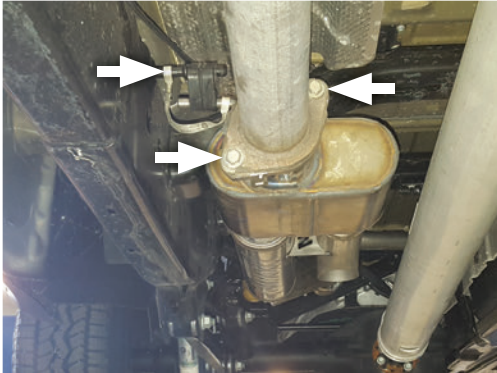

10. Plug **wire assembly (6)** end into actuator motor then tape off remaining plug in.

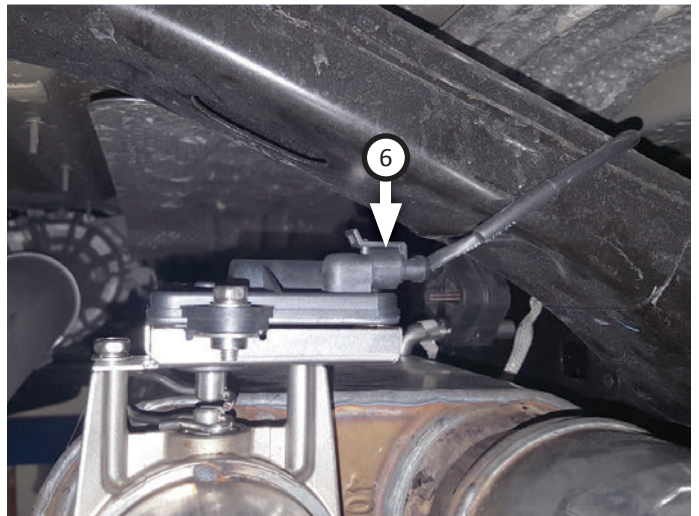

NOTE: You may secure wire assembly several different ways; **zip tie (15)** it to factory wire bundle, tuck it behind heat shield, secure it to frame, etc. Just be sure that connections are stable and wire is protected from heat.

11. Route length of wire assembly along passenger side of vehicle to front axle then up through engine compartment to driver side.



12. Set **controller kit (5)** inside driver side of cab. Find wiring entry point into firewall (behind battery on driver side) then cut an X in accessory point or cut its end off.

NOTE: You will need to use a stiff wire to complete steps 13-14. We recommend using a coat hanger wire.



13. Thread hanger wire into cab through accessory point from last step. Then bend wire and connect it to controller kit end. Tape over connection to secure it.



14. Cover connection with lubricant then pull it back through accessory point.



15. Remove wire, tape and lubricant from controller kit end. Pull wire assembly up and connect ends together. Secure any slack away from moving and heated engine components.



16. Open underside of dashboard under driver side. Fasten controller kit to a point up and away from interfering with vehicle operation.



17. Strip end of controller kit red wire. Connect **fused circuit tap (17)** to it then crimp connection.

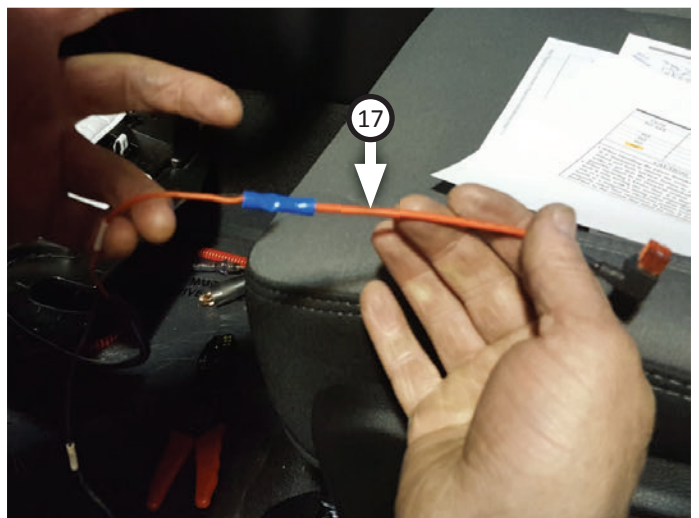
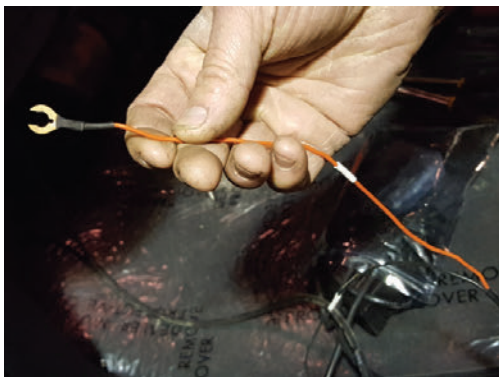

18. Pull factory fuse from F66 (Run - Accessory Feed) in fuse box. Plug it and **fuse (16)** into fused circuit tap, route wire over to fuse box then plug it back into F66 as shown. Secure any wire slack up and out of the way.

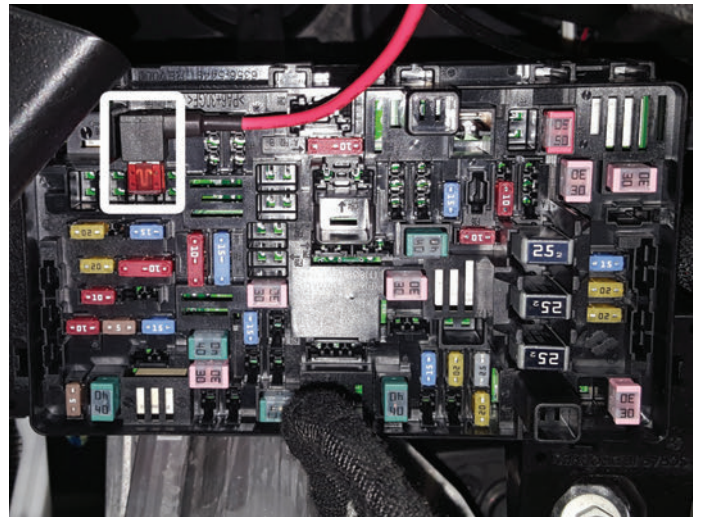
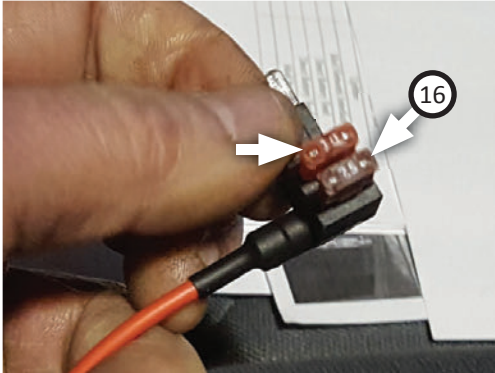

19. Attach black ground wire to metal frame. Re-install console covers and tuck all loose wire out of the way.



20. Adjust muffler for proper fit then tighten all clamps. Secure wiring beneath vehicle, tucking away slack and maintaining clearance from moving and heated components of vehicle, utilizing provided zip ties.
21. Slide **hanger keepers (x3) (HW503)** onto each sideways hanger to secure exhaust system.
22. We recommend applying a one inch tack weld to all slip-fit connections. Applying high temperature paint over welded areas can prevent rust and premature corrosion.

Congratulations, the installation of your FLOWMASTER performance exhaust system is now complete!





Installation Instructions
717915
2019*-20 RAM 1500
5.7L HEMI ENGINE
2/4 Wheel Drive, All Wheelbases
With Factory Single or Dual Tailpipes
(*Does Not fit 2019 Classic Body)

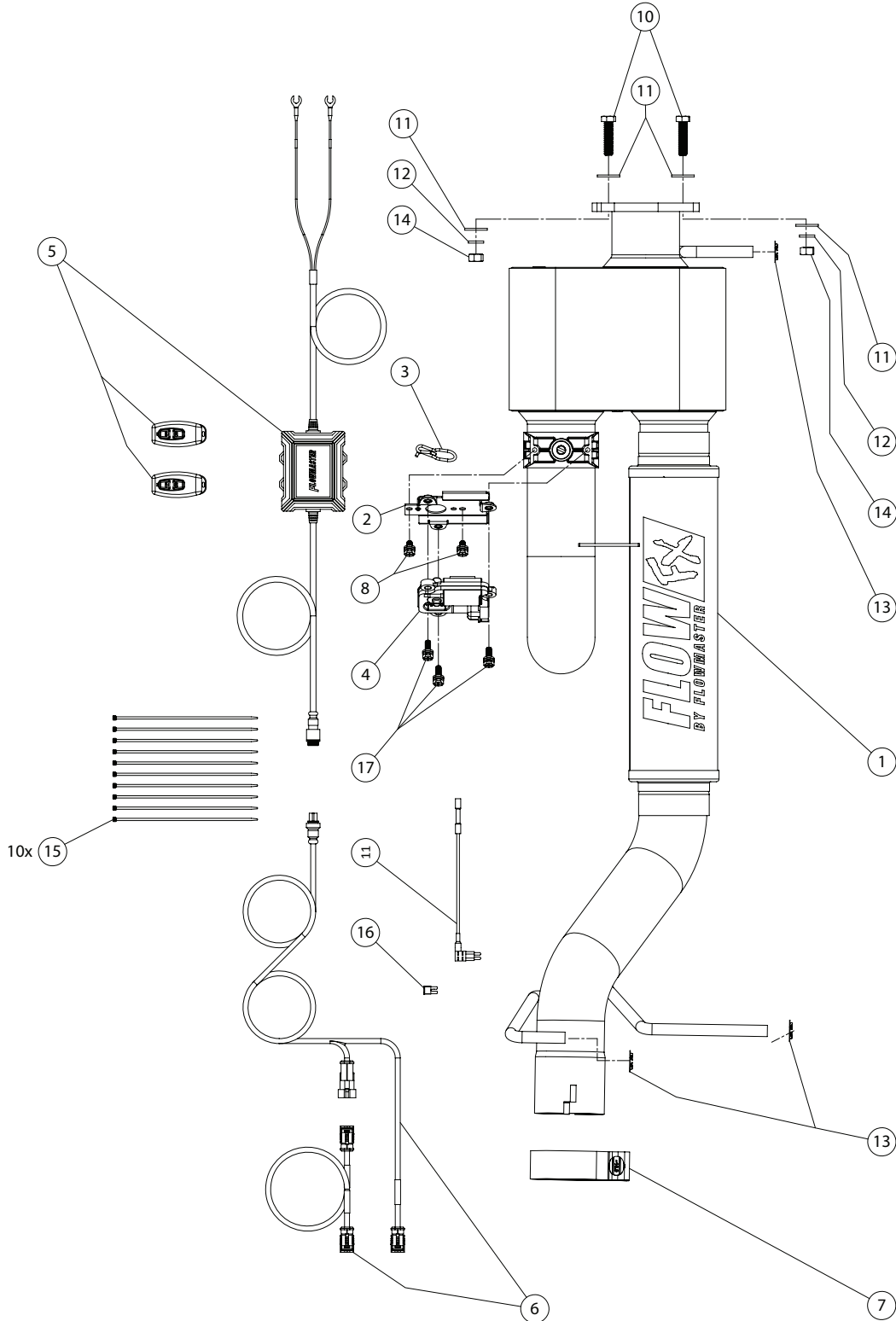

[View other performance exhaust systems made by Flowmaster on our website.](#)