

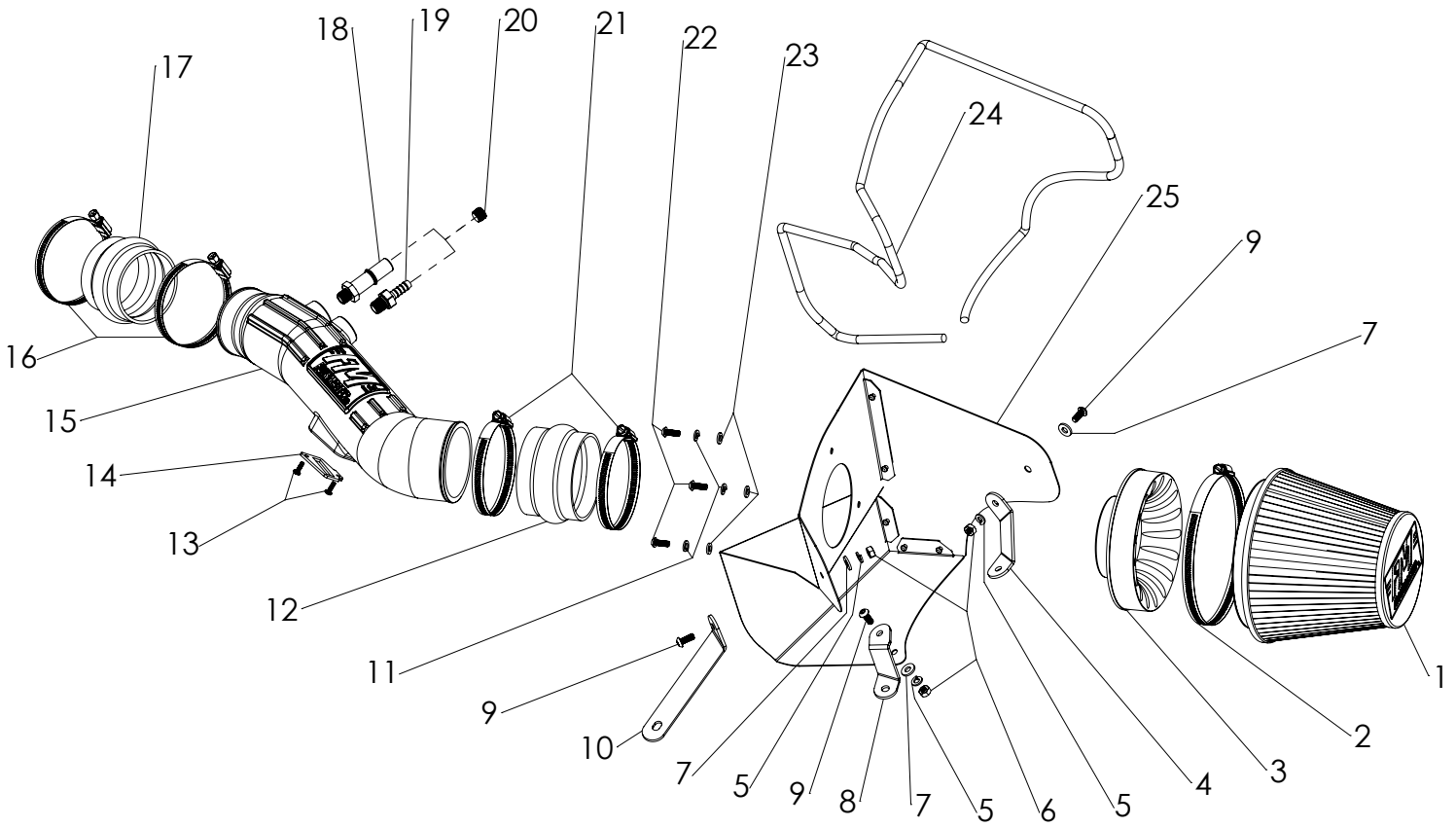

Installation Instructions for:  
**SYSTEM #615146**  
 2011-2014 MUSTANG  
 3.7L Engine

NOT LEGAL FOR SALE OR USE ON ANY POLLUTION-CONTROLLED MOTOR VEHICLE IN CALIFORNIA OR IN STATES THAT HAVE ADOPTED CALIFORNIA EMISSION PROCEDURES.



**NOTE:** ITEM 20 (1/4" NPT PLUG) IS AN OPTION THAT MAY BE USED IN PLACE OF EITHER FITTING 18 OR 19, DEPENDING ON YOUR VEHICLE'S CONFIGURATION. SEE INSTRUCTIONS FOR FURTHER DETAILS.

ITEM NO.	PART NUMBER	DESCRIPTION	QTY.
1	AF1003	FILTER, AIR 6.625" HIGH, Ø 6" FLANGE	1
2		#104 HOSE CLAMP Ø 4.125 TO 7"	1
3	AF6001	3.5" AIR FILTER ADAPTER	1
4	AF5026	11 GA X 1" BRACKET #1, 11-14 MUSTANG V6 3.7L	1
5	HW322	1/4" SPLIT LOCK WASHER SS	3
6	HW115	1/4"-20 NUT SS	3
7	HW320	1/4" FLAT WASHER SAE SS	3
8	AF5028	11 GA X 1" BRACKET #3, 11-14 MUSTANG V6 3.7L	1
9	HW245	1/4"-20 X 5/8" BTNHD SS	3
10	AF5027	11 GA X 1" BRACKET #2, 11-14 MUSTANG V6 3.7L	1
11	HW318	M6 SPLIT LOCK WASHER SS	3
12	AF4019	3.5"ID X 2.5"L RUBBER COUPLER, HUMP	1
13	HW248	M4 X 0.7 X 12MM RH PHILLIPS SCREW SS	2

ITEM NO.	PART NUMBER	DESCRIPTION	QTY.
14	GA139	MAF SENSOR GASKET	1
15	AF2020	MOLDED INTAKE TUBE, 11-14 MUSTANG V6, 3.7L	1
16	MC314H	#52 HOSE CLAMP Ø 2 13/16 TO 3 3/4"	2
17	AF4036	3.0"ID X 2.5"L RUBBER COUPLER, HUMP	1
18	AF4016	5/8" QUICK CONNECT TO 1/4" NPT MALE, STRAIGHT	1
19	AF4040	3/8" BARB TO 1/4" NPT MALE STRAIGHT	1
20	AF4033	1/4" NPT ALUM. PLUG	1
21	MC350H	#56 HOSE CLAMP Ø 3 1/16 TO 4"	2
22	HW244	M6 X 1.0 X 16MM BTNHD SS	3
23	HW319	M6 FLAT WASHER SS	3
24	49000061	HEAT SHIELD GASKET	1
25	AF3015	HEAT SHIELD, 11-14, MUSTANG, 3.7L	1





7. Use a flat-tip screwdriver to release the clip securing the MAF lead to the airbox.

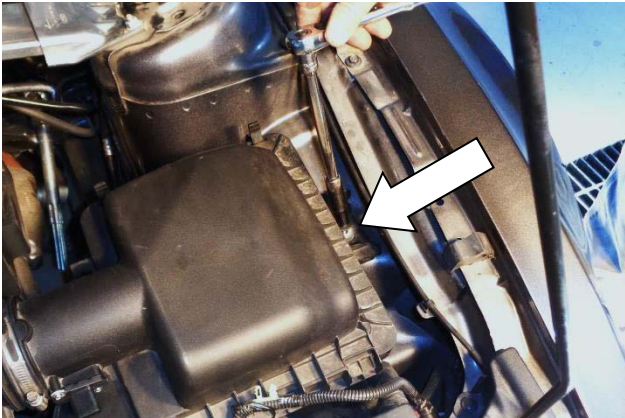

8. Remove and retain the airbox mount bolt.



9. Loosen the hose clamp securing the intake duct to the throttle body, and remove the duct from the throttle body.



10. Remove the assembled airbox and duct from the vehicle.



11. Remove the MAF sensor from the airbox, then remove the stock gasket from the sensor.  
**CAUTION: The sensor is delicate! Handle it with care, and store it in a safe location until reinstallation.**

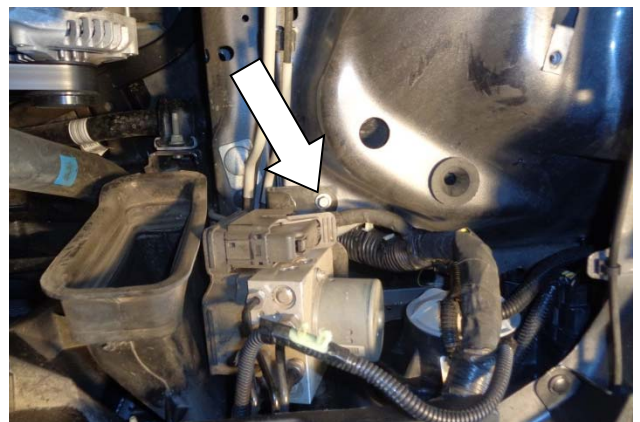

12. Remove and retain the lower mount bolt.

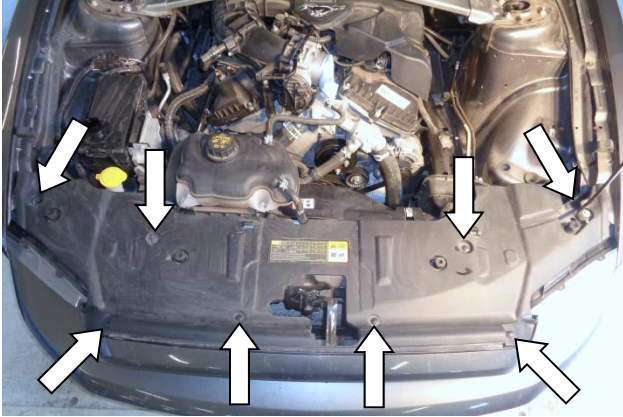

13. Use a flat-tip screwdriver to release the eight radiator support cover fasteners at the locations shown. Remove the fasteners entirely (both heads and sleeves), then remove the cover.

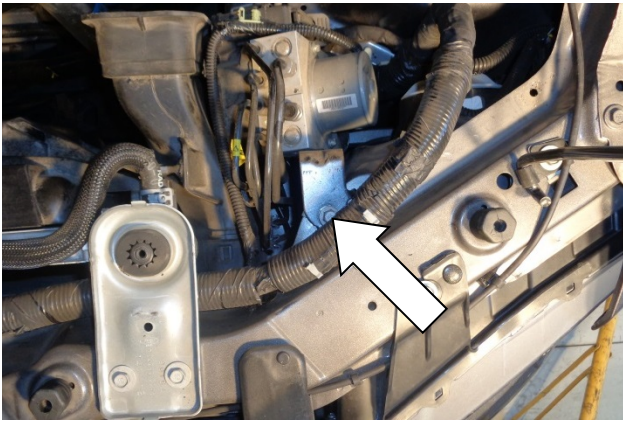

14. Remove and retain the upper mount bolt (hidden behind the cable bundle).

**ASSEMBLE AND INSTALL YOUR FLOWMASTER COLD AIR INTAKE SYSTEM:**



15. Attach bracket (10) to heat shield (25) using ¼-20 × 5/8" screw (9) (against bracket) and flat washer (7), lock washer (5) and nut (6) (against heat shield).

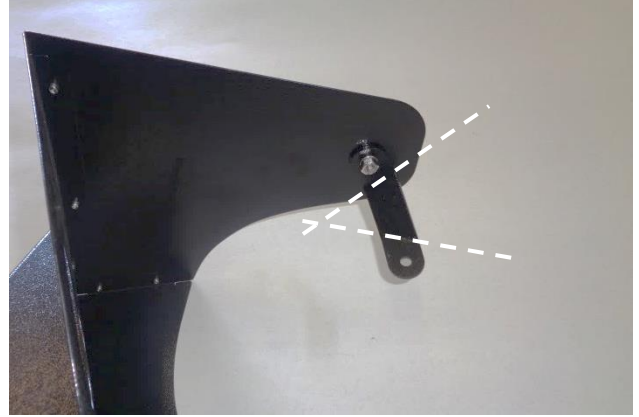

16. Attach bracket (4) to heat shield using ¼-20 × 5/8" screw (9) and flat washer (7) (against heat shield), and lock washer (5) and nut (6) (against bracket). Note orientation of bracket bend lines.



17. Attach bracket (8) to heat shield using ¼-20 × 5/8" screw (9) (against bracket), and flat washer (7), lock washer (5) and nut (6) (against heat shield).



18. Assemble air filter adapter (3) to heat shield using M6 screws (22), lock washers (11) and flat washers (23).



19. Attach the gasket (24) to the heat shield. Starting on either side of bracket (8), gradually work around the heat shield, firmly pressing the seal onto the edge. When you return to the bracket, trim seal to fit using metal-cutting shears.

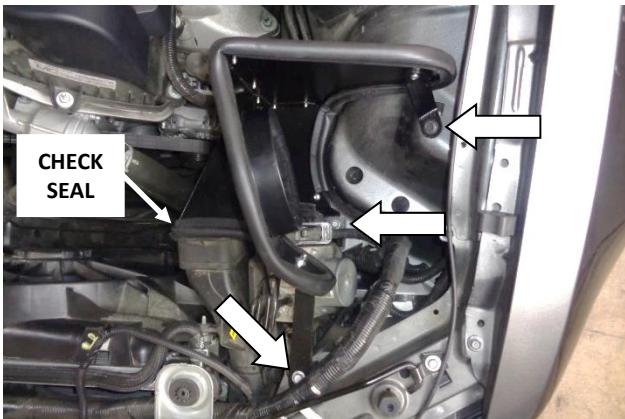

20. Install heat shield in vehicle, securing the brackets with the factory bolts removed earlier. If necessary, adjust alignment of the brackets, then retighten their fasteners. Verify even contact between heat shield gasket and lip seal on stock air duct.

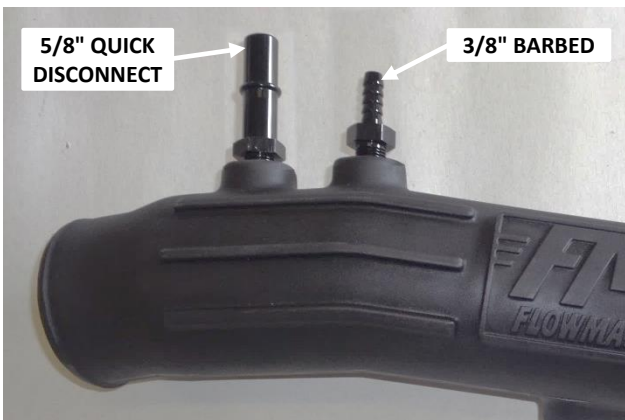

21. Determine which vacuum fitting(s) are required for your vehicle's configuration. The 5/8" quick disconnect fitting (18) mates with the PCV hose latching connector. The 3/8" barbed fitting (19) mates with the EVAP system hose.



22. Your vehicle may require one or both vacuum fittings. If it uses only one fitting, the 1/4" plug (20) will be used in the unused port. Apply 2 wraps of nylon thread tape to threads of the required hardware, and install them in intake tube (15), in the appropriate ports.



23. Install two small hose clamps (16) on small flex coupler (17), and install coupler on discharge end of intake tube. Only snug the clamps at this time, to allow adjustment when tube is installed.



24. Install two large hose clamps (21) on large flex coupler (12), and install coupler on intake end of intake tube. Only snug the clamps at this time, to allow adjustment when tube is installed.



25. Slip the MAF sensor gasket (14) over the sensor, ensuring correct orientation. Then install the sensor in intake tube, using M4 screws (13).



28. Install the left coupler on the throttle body.

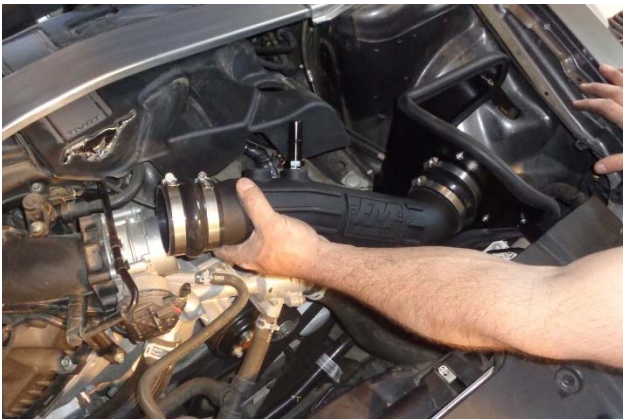

26. It is recommended that the assembled intake tube be installed as follows. First, install the right coupler on the filter adapter.

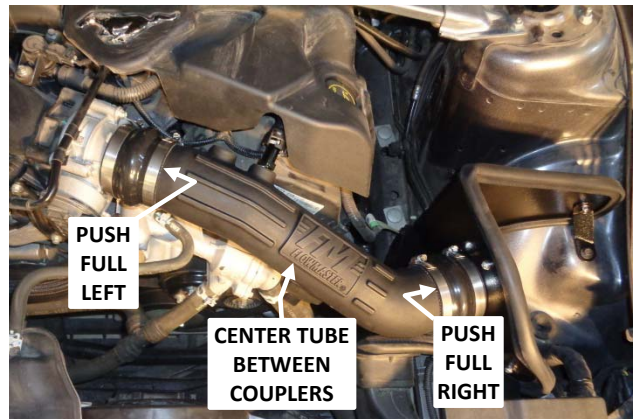

29. Push the left coupler up against the raised stop on the throttle body. Push the right coupler up against the heat shield. Then center the intake tube between the couplers, and tighten all hose clamps.



27. Then connect the vacuum hose(s) to their respective fitting(s).



30. If your vehicle has a latching PCV fitting, secure it by pushing the latch to the right until it clicks.



31. Install clamp (2) on air filter (1), then install filter on filter adapter and tighten clamp.



32. Plug the MAF sensor lead into the sensor, push the latch in, and verify the connector is secure.



33. Secure the loose MAF sensor lead away from any moving parts, using the factory clip or cable ties.



34. If your vehicle includes the optional engine cover, remove the oil fill cap, reinstall the fill cap extension (removed at Step 4), then reinstall the fill cap.



35. Reinstall the radiator support cover and secure with the 6 fasteners (removed at Step 13).



**Congratulations, the installation of your FLOWMASTER cold air intake kit is now complete!**