

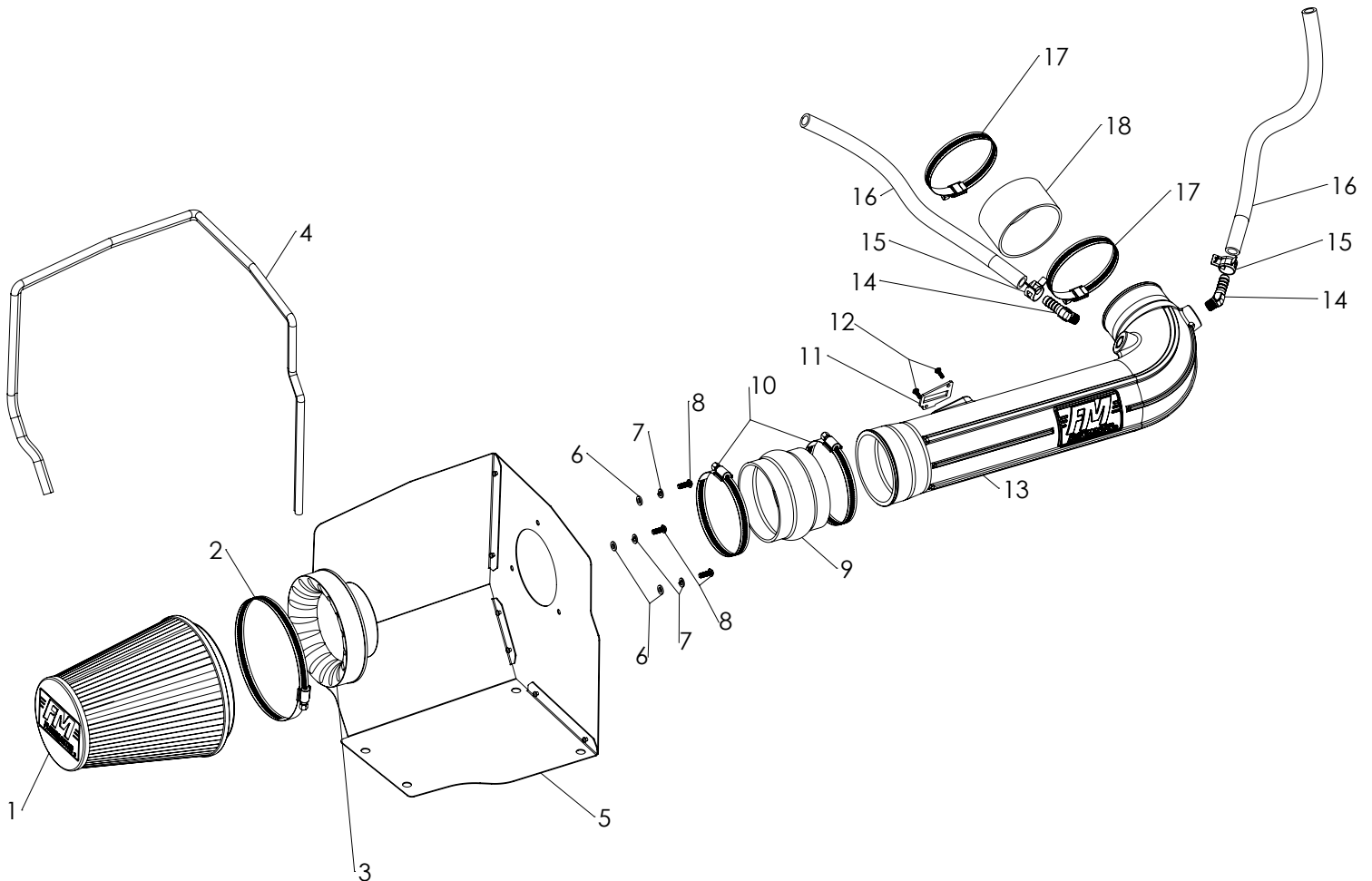

Installation Instructions for: SYSTEM # 615121D

**2014-2018 GM TRUCKS
& 2015-2018 GM SUVs
WITH 5.3L/6.2L Engine**

NOT LEGAL FOR SALE OR USE ON ANY POLLUTION-CONTROLLED MOTOR VEHICLE IN CALIFORNIA OR IN STATES THAT HAVE ADOPTED CALIFORNIA EMISSION PROCEDURES.



ITEM NO.	PART NUMBER	DESCRIPTION	QTY.
1	AF1005	AIR FILTER, 8-5/8" x 6" DIA	1
2	AF1005	SCREW CLAMP, #104 (4-1/8" - 7")	1
3	AF6002	ADAPTER, AIR FILTER 4" x 6"	1
4	49000061	GASKET, HEAT SHIELD	1
5	AF3011	HEAT SHIELD, 14-18 GM TRUCK, 15-18 SUV, 5.3L	1
6	HW319	FLAT WASHER, M6	3
7	HW318	LOCK WASHER, M6	3
8	HW244	SCREW, M6 x 1.0 x 16MM	3
9	AF4005	COUPLER, FLEX 4" I.D. x 3" L	1
10	MC400H	SCREW CLAMP, #64 (3-9/16" - 4-1/2")	2

ITEM NO.	PART NUMBER	DESCRIPTION	QTY.
11	GA139	GASKET, MAF SENSOR	1
12	HW248	SCREW, M4 x 0.7 x 12MM	2
13	AF2011	INTAKE TUBE, 14-18, GM TRUCK, 15-18 SUV, 5.3L	1
14	AF4029	ELBOW, 45°, 1/2" BARB TO 1/4" NPT MALE	2
15	MC003P	PINCH CLAMP, 1/2" HOSE	2
16	49000064	HOSE, 1/2" I.D.	36"
17	MC350H	SCREW CLAMP, #56 (3-1/16" - 4")	2
18	AF4007	COUPLER, STRAIGHT 3-1/2" I.D. x 2" L	1
19	615004P	PRE FILTER WRAP (NOT SHOWN)	1

REVIEW THE INSTRUCTIONS AND VERIFY THE KIT CONTENTS:

1. Please take a moment to read and understand these instructions before installing your Flowmaster cold air intake kit.



2. Use the parts drawing and list (front page) to verify your kit's contents.

In the unlikely event that any parts are missing, please contact FLOWMASTER Technical Support for replacements.

REMOVE THE FACTORY AIR INTAKE SYSTEM:

NOTES

- We highly recommend that you retain all factory air intake system parts.
 - Please refer to vehicle manufacturer's recommendations regarding removal of factory components.
 - Disconnecting the negative battery cable erases pre-programmed electronic memories. Write down all memory settings before disconnecting the negative battery cable. Some radios will require an anti-theft code to be entered after the battery is reconnected. The anti-theft code is typically supplied with your owner's manual. In the event your vehicle's anti-theft code cannot be recovered, contact an authorized dealership to obtain your vehicle's anti-theft code.
3. Turn off the vehicle's ignition and disconnect the negative battery cable.

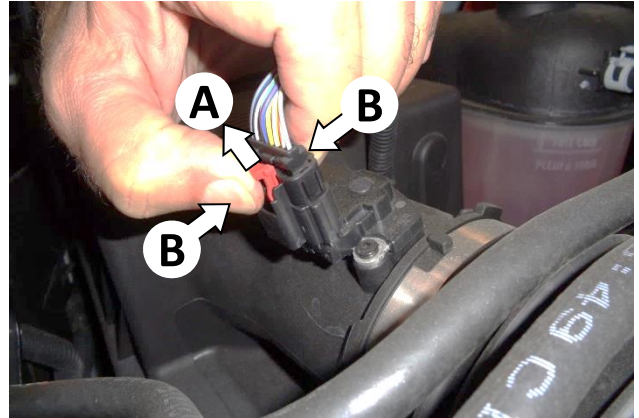

4. Disconnect the mass airflow (MAF) sensor plug by:
 - A. pulling the locking tab away from the sensor until it stops; then
 - B. squeezing the sides of the plug while pulling it straight off the sensor.



5. Release the clamp holding the MAF sensor wire from the corner of the airbox.



6. Locate the two PCV hose connectors at the back of the intake plenum as shown.



7. Disconnect both PCV hose connectors from the intake plenum by depressing their release latches and pulling straight off.

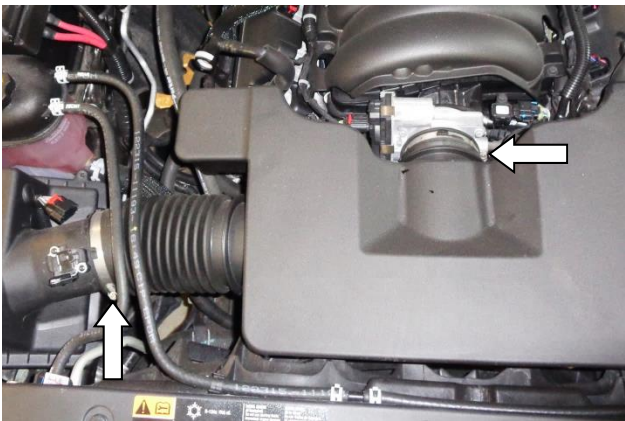

8. Loosen the two screw clamps shown – one at the airbox, and the other at the throttle body.



9. Separate the intake duct from the airbox, separate the intake plenum from the throttle body, and carefully remove the assembled duct and plenum from the vehicle.



10. Remove both PCV hoses from the valve covers by depressing their release latches and pulling straight off.

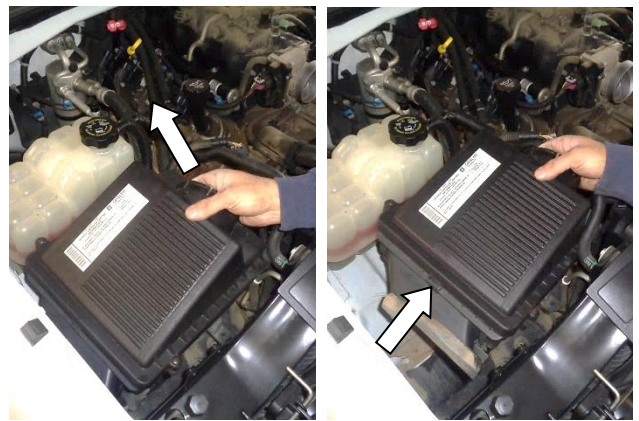

11. To remove the stock airbox, grasp the inlet side and lift it straight up to release the 2 mount pins from their rubber grommets. Then slide the airbox inboard to release it from the airbox shelf.

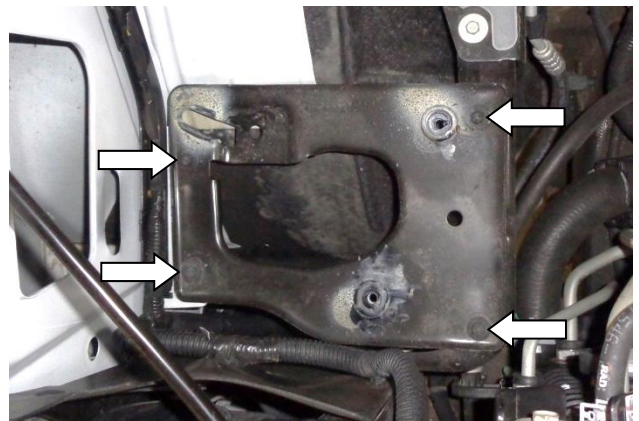

12. Remove the airbox shelf by removing its 4 mount bolts. Retain the bolts for reinstallation at Step 16. **NOTE: To maintain proper bolt clearances at installation, note the length of bolt removed from each location.**



13. Remove the MAF sensor from the airbox, then remove the factory gasket from the sensor.
CAUTION: The sensor is delicate! Handle it with care, and store it in a safe location until reinstallation.



15. Attach the gasket (4) to the heat shield. Starting at the bottom of the front edge, firmly press the seal onto the edge, gradually working your way around. At the bottom of the opposite edge, trim the seal using metal-cutting shears.

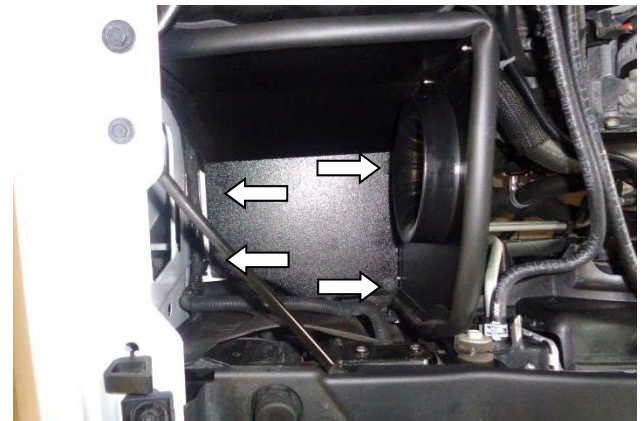

16. Use the 4 bolts retained at Step 12 to install the assembled heat shield in the vehicle. **NOTE: At each location, be sure to use the same length bolt as was removed (see Step 12).**

ASSEMBLE AND INSTALL YOUR FLOWMASTER COLD AIR INTAKE SYSTEM:

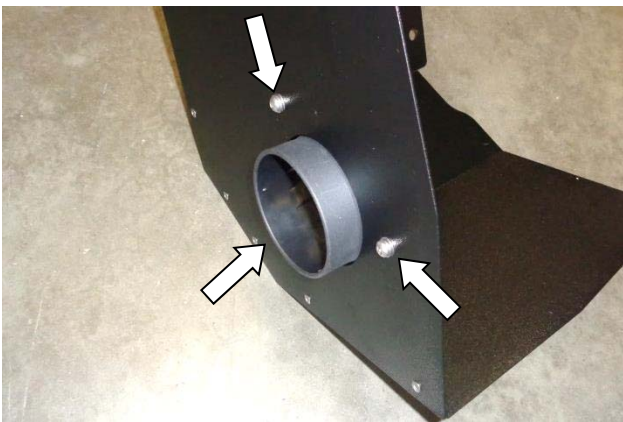

14. Assemble the air filter adapter (3) to the heat shield (5) using the M6 screws (8), lock washers (7) and flat washers (6).



17. Apply 2 wraps of nylon thread tape to the threads of 2 barbed elbows (14), and install the elbows into the intake tube (13), pointing them toward the tube opening.



18. Install the MAF sensor gasket (11) onto the sensor, ensuring correct orientation. Then install the sensor in the intake tube, using the M4 screws (12).



19. Slip the 2 small screw clamps (17) onto the straight coupler (18). Push the coupler onto the throttle body-end of the intake tube. Snug the tube clamp (do not tighten at this time), and leave the other clamp loose.



20. Slip the 2 large screw clamps (10) onto the flex coupler (9). Push the coupler onto the filter-end of intake tube. Snug the tube clamp (do not tighten at this time), and leave the other clamp loose.

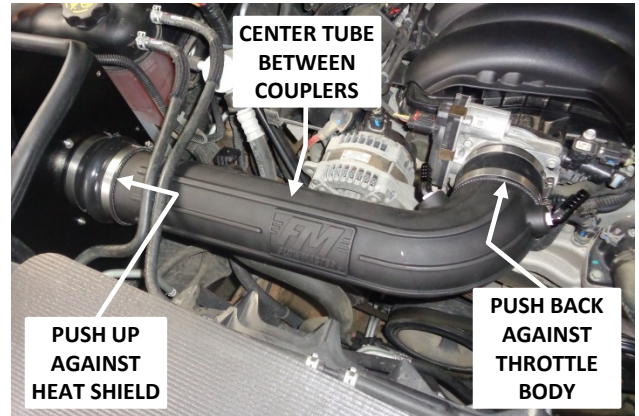

21. Install the intake tube in the vehicle. Push the rear coupler back against the throttle body and tighten the throttle body clamp. Push the left coupler up flush against the heat shield and tighten the heat shield clamp. Then center the tube between the couplers, and tighten both tube clamps.

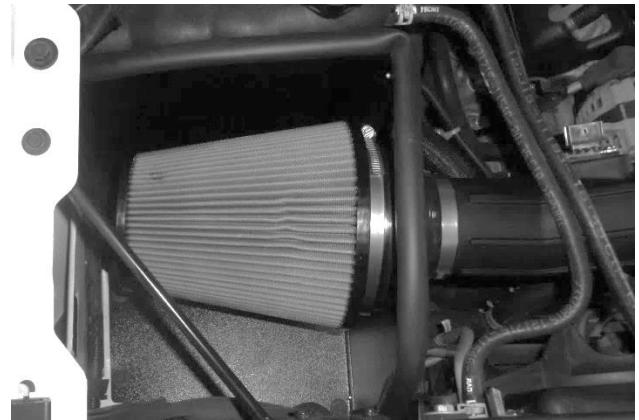

22. Install clamp (2) on air filter (1), install filter on filter adapter and tighten clamp. If desired, install pre-filter (19) over the cone element. This will help extend the life of the filter by keeping out the larger particles.



23. Cut 2 pieces of 1/2" ID hose (16) to 14-15 inches long.

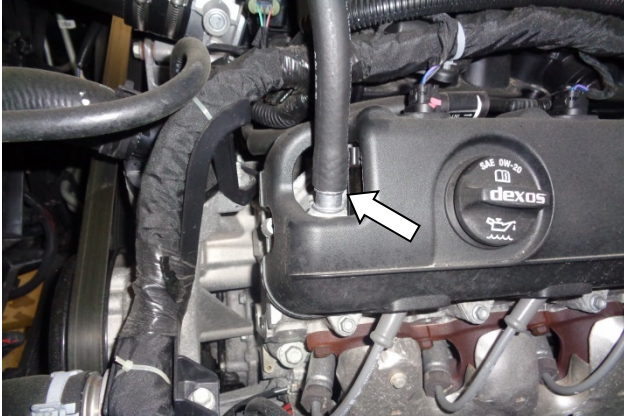

24. Install a hose on the PCV port on each valve cover (2 places). Push each hose fully onto the port, until it touches the raised lip.



26. Reconnect the MAF sensor plug to the sensor, close the locking tab, and verify that the connection is secure.

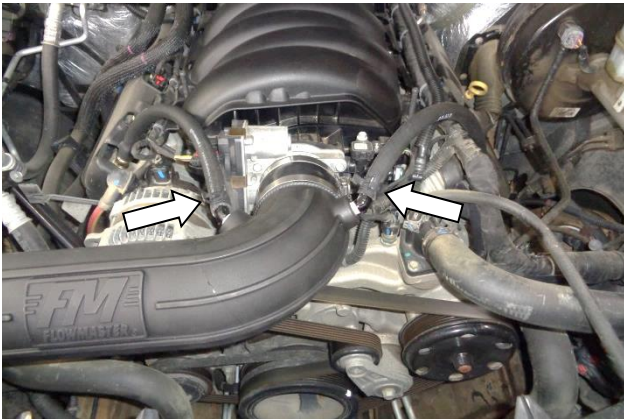

25. Push the other ends of the hoses onto the barbed elbows and secure with pinch clamps (15).



Congratulations, the installation of your FLOWMASTER cold air intake kit is now complete!