

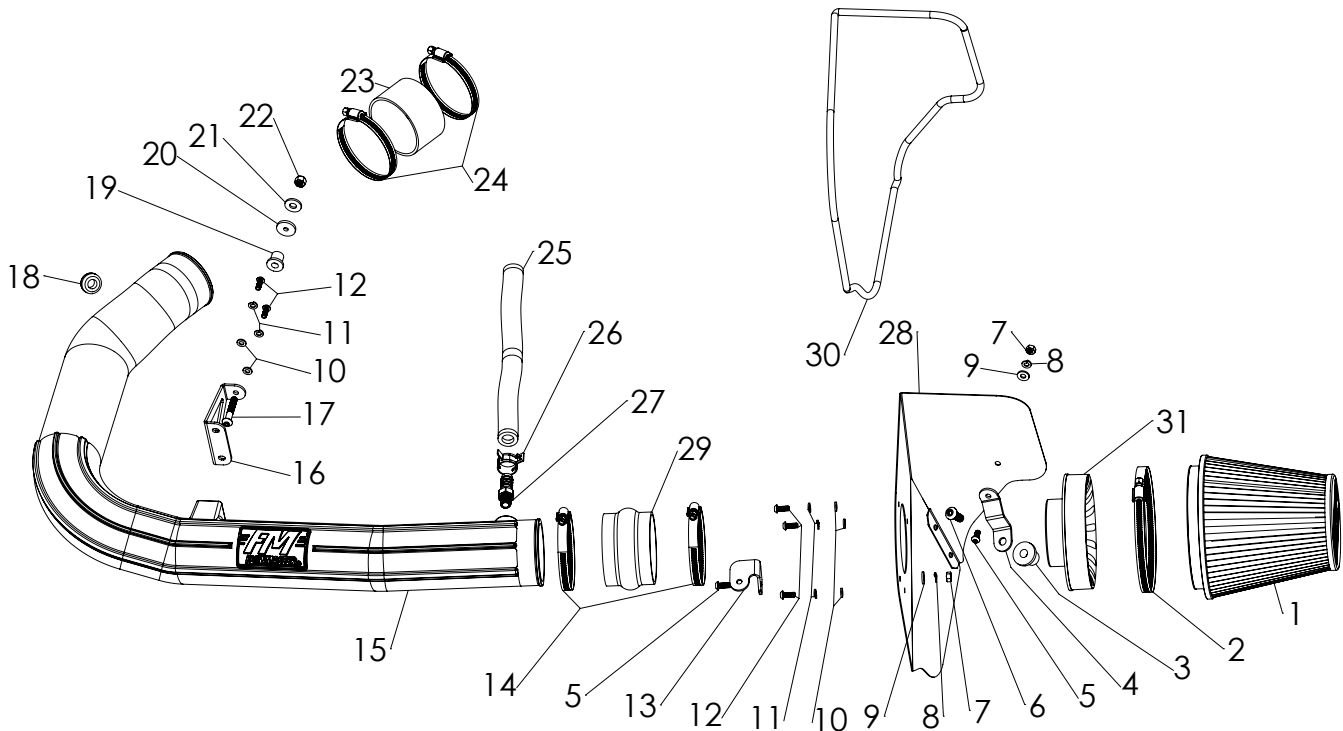

# Installation Instructions for: SYSTEM # 615106 2011-2017 MOPAR CARS 3.6L Engine

NOT LEGAL FOR SALE OR USE ON ANY POLLUTION-CONTROLLED MOTOR VEHICLE IN CALIFORNIA OR IN STATES THAT HAVE ADOPTED CALIFORNIA EMISSION PROCEDURES.



ITEM NO.	PART NUMBER	DESCRIPTION	QTY.
1		FILTER, AIR 7.5" HIGH, Ø6" FLANGE	1
2	AF1002	#104 HOSE CLAMP Ø 4.125 TO 7"	1
3	HW119	RUBBER WELL NUT, 3/8"-16	1
4	AF5017	BRACKET 2, 2017, DODGE CARS, 6.2L	1
5	HW245	1/4"-20 x 5/8" SCREW	2
6	HW250	3/8"-16 x 1.125" SCREW	1
7	HW115	1/4"-20 NUT	2
8	HW322	1/4" SPLIT LOCK WASHER	2
9	HW320	1/4" FLAT WASHER	2
10	HW319	M6 FLAT WASHER	5
11	HW318	M6 SPLIT LOCK WASHER	5
12	HW244	M6 x 1.0 x 16MM SCREW	5
13	AF5016	BRACKET 1, 2017, DODGE CARS, 6.2L	1
14	MC350H	#56 HOSE CLAMP Ø3 1/16 TO 4"	2
15	AF2022	11-17 CHALL/ CHARG BASE V6 3.6L INTAKE TUBE	1
16	AF5029	11 GA TUBE BRACKET, 11-17 DODGE CARS, V6 3.6L	1

ITEM NO.	PART NUMBER	DESCRIPTION	QTY.
17	HW258	5/16"-18 x 1-3/4" SCREW	1
18	AF4008	GROMMET, RUBBER 1.06" OD x 1/2" ID x 7/16" THK	1
19	HW122	RUBBER WELL NUT, 5/16"-18	1
20	HW328	RUBBER CUSHION WASHER, .25" ID, 1" OD	1
21	HW327	FENDER WASHER, .375" ID, .875" OD	1
22	HW121	5/16"-18 NYLON-INSERT LOCKNUT	1
23	AF4025	3.25" ID X 2" L RUBBER COUPLER, STRAIGHT	1
24	MC314H	#52 HOSE CLAMP Ø2-13/16 TO 3-3/4"	2
25	49000068	5/8" ID FUEL HOSE	1
26	MC004P	5/8" HOSE PINCH CLAMP	1
27	AF4032	5/8" HOSE BARB TO 1/4" NPT MALE STRAIGHT	1
28	AF3022	11-17 CHALL/CHARG BASE V6 HEAT SHIELD	1
29	AF4019	3.5" ID X 2.5" L RUBBER COUPLER, HUMP	1
30	49000061	PUSH ON VINYL HEAT SHIELD GASKET	1
31	AF6001	3.5" AIR FILTER ADAPTER	1

## REVIEW THE INSTRUCTIONS AND VERIFY THE KIT CONTENTS:

1. Please take a moment to read and understand these instructions before installing your Flowmaster cold air intake kit.



2. Use the parts drawing and list (front page) to verify your kit's contents.

In the unlikely event that any parts are missing, please contact FLOWMASTER Technical Support for replacements.

To simplify assembly and avoid cross-threading fasteners, identify and separate the 1/4-20 screws, item (5) (used with nuts (7)), and the M6 screws (12) (used with filter adapter (31)).

## REMOVE THE FACTORY AIR INTAKE SYSTEM:

### NOTES

- We highly recommend that you retain all factory air intake system parts.
- Please refer to vehicle manufacturer's recommendations regarding removal of factory components.
- Disconnecting the negative battery cable erases pre-programmed electronic memories. Write down all memory settings before disconnecting the negative battery cable. Some radios will require an anti-theft code to be entered after the battery is reconnected. The anti-theft code is typically supplied with your owner's manual. In the event your vehicle's anti-theft code cannot be recovered, contact an authorized dealership to obtain your vehicle's anti-theft code.

3. Turn off the vehicle's ignition and disconnect the negative battery cable.



4. Remove the engine cover by firmly lifting at each corner to release it from its four friction clips.



5. Carefully pull the hard plastic breather line from the hose on the airbox.

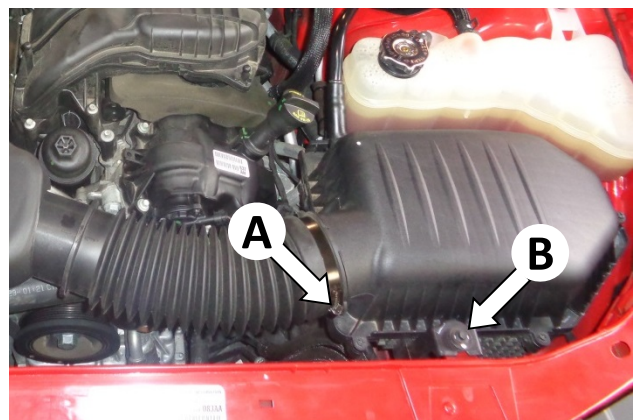

6. Loosen the hose clamp securing the air intake duct to the airbox (A). Remove airbox mount bolt (B) and retain for reinstallation at Step 16.

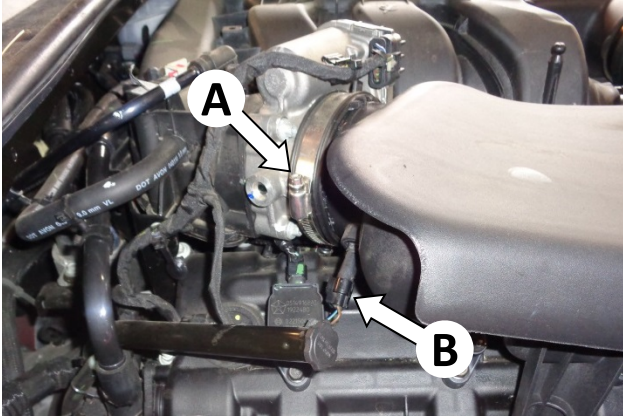

7. Loosen the hose clamp securing the air intake duct to the throttle body (A). Disconnect the air temperature sensor plug (B).



8. Carefully disconnect the intake duct from both the throttle body and the airbox, then remove it from the vehicle.



9. Remove the airbox from the vehicle.

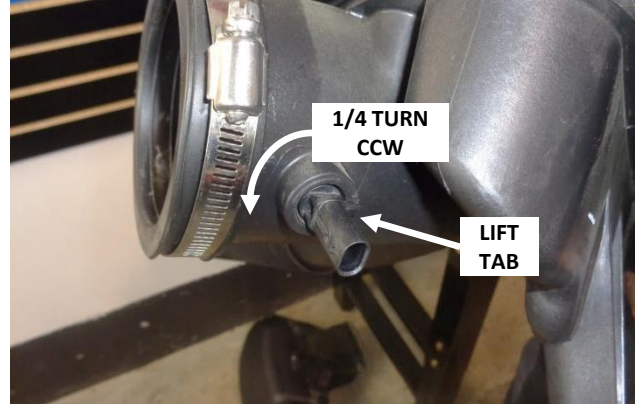

10. Remove the air temp sensor from the intake duct by lifting the locking tab, then turning the sensor a quarter-turn counter-clockwise. Then remove the o-ring from the sensor. **CAUTION: The sensor is delicate!** Handle it with care, and store it in a safe location until reinstallation.

### ASSEMBLE AND INSTALL YOUR FLOWMASTER COLD AIR INTAKE SYSTEM:

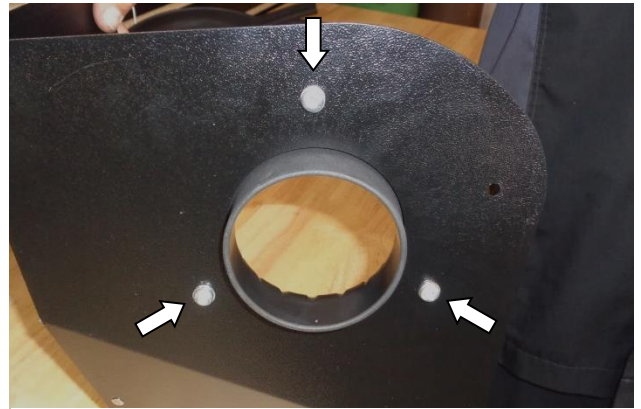

11. Assemble air filter adapter (31) to heat shield (28) using M6 screws (12), lock washers (11) and flat washers (10).



12. Attach bracket (13) to heat shield using ¼-20 screw (5) (against the bracket) and nut (7), lock washer (8) and flat washer (9) (against the heat shield). Do not fully tighten hardware at this time.



13. Attach bracket (4) to heat shield using ¼-20 screw (5) (against the bracket), and nut (7), lock washer (8) and flat washer (9) (against the heat shield). Do not fully tighten hardware at this time.



14. Attach gasket (30) to heat shield. Starting at the corner shown, firmly press the gasket onto the edge, gradually working around the heat shield. When you return to the starting point, trim the gasket to fit using metal-cutting shears.



15. Insert 3/8-16 rubber well nut (3) in airbox mount hole in wheel well.

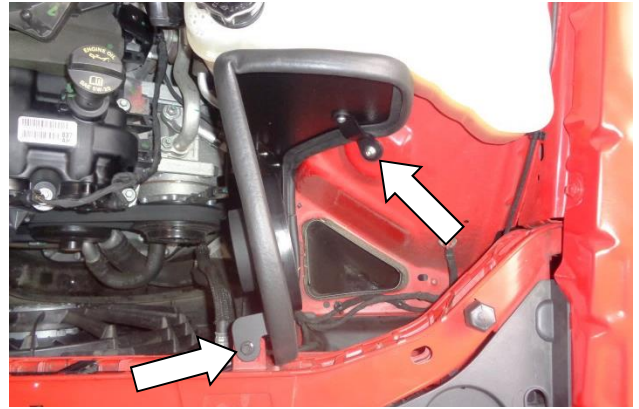

16. Place the assembled heat shield in the vehicle. Adjust the alignment of the brackets. Secure the rear bracket with 3/8-16 screw (6), secure the front bracket with stock bolt removed at Step 6, and tighten the bracket hardware.



17. Apply 2 wraps of nylon thread tape to threads of 5/8" fitting (27), and install it in the intake tube (15). Attach bracket (16) to intake tube using M6 screws (12), lock washers (11), and flat washers (10). Do not tighten bracket hardware at this time.

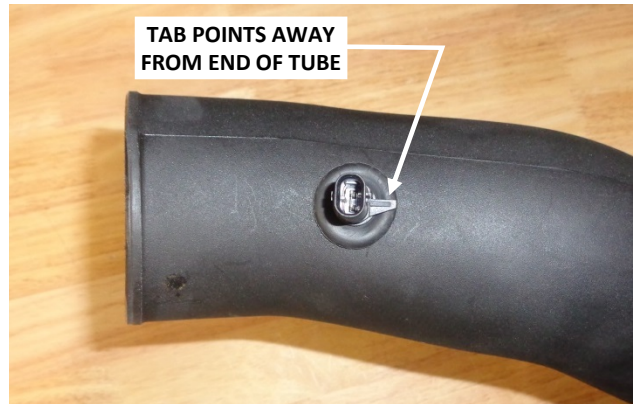

18. Install rubber grommet (18) in intake tube. Carefully insert the air temp sensor into the grommet, so that the tab points away from the end of the tube. (NOTE: Moisten the grommet hole with soapy water to ease insertion.)



19. Install 5/8" ID hose (25) on the barbed fitting and secure with pinch clamp (26). (Install full length of hose; it will be cut to length later.)



20. Install two large hose clamps (14) on flex coupler (29), and install coupler on airbox end of tube. Do not fully tighten the hose clamps at this time.



21. Install two small hose clamps (24) on straight coupler (23), and install coupler on throttle body end of tube. Do not fully tighten the hose clamps at this time.

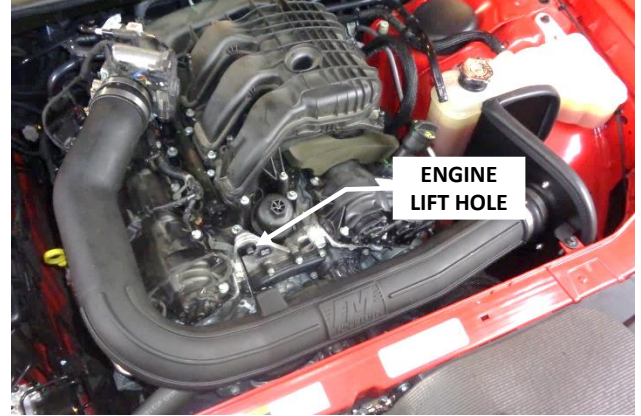

22. Install the intake tube in the vehicle. Leave hose clamps loose at this time. Note the engine lift hole behind bracket (16).

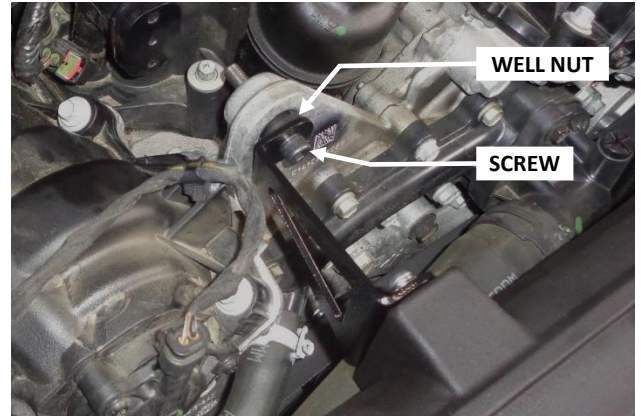

23. Insert 5/16-18 rubber well nut (19) in engine lift hole, then insert the 5/16-18 screw (17) through the bracket into the well nut. Tighten the screw until the well nut expands against the inside of the hole.

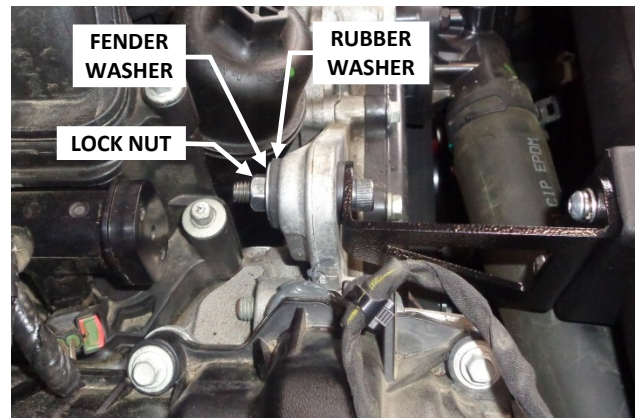

24. Install rubber washer (20), fender washer (21) and lock nut (22) hand tight on screw (17). Then tighten the 2 bracket screws (12). Finally, tighten locknut (22) while holding screw (17) stationary.

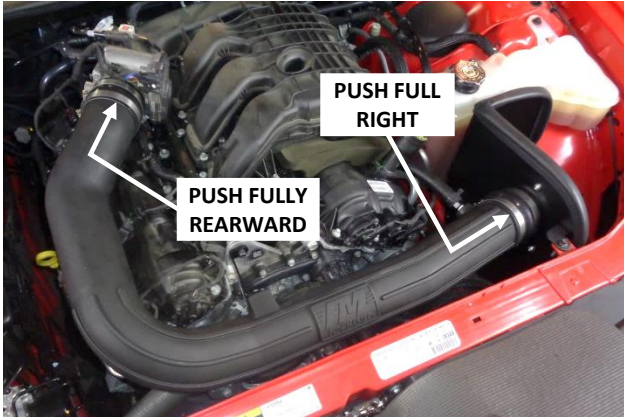

25. Push the straight coupler up against the throttle body. Push the flex coupler up against the heat shield. Then tighten all hose clamps.

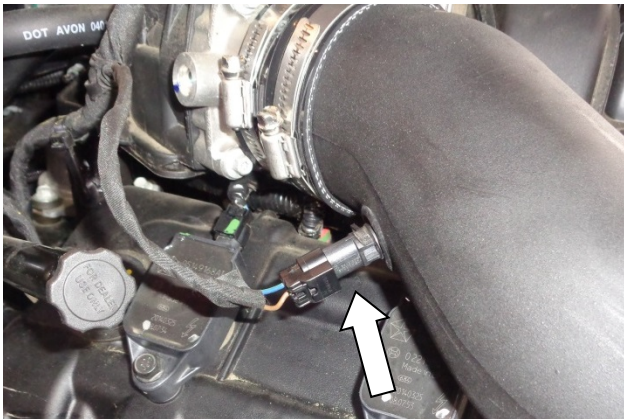

26. Plug the air temp sensor lead into the sensor until it clicks, then verify the connection is secure.

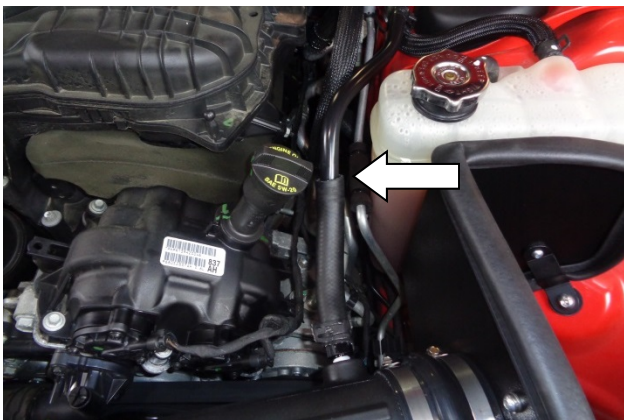

27. Cut the breather hose to the required length (i.e., to the lip on the hard plastic breather line), then push the hose onto the breather line (to the lip).



28. Place clamp (2) on air filter (1), install filter on filter adapter and tighten clamp.



29. Align the engine cover over its four mount posts, then snap it into place at all four corners.



**Congratulations, the installation of your FLOWMASTER cold air intake kit is now complete!**