



FORCE II SYSTEM #17362

1999-2005 CHEVROLET / GMC C/K 1500 TRUCK
4.8L & 5.3L ENGINES • EXTENDED CAB, SHORT BED

Removal:

- 1) Raise the vehicle up on a hoist or rack to working height. If you do not have access to a hoist or rack raise the vehicle and support securely with jack stands.
- 2) Using a hacksaw or sawsall, cut the stock tailpipe off where it exits the muffler. (This step is not mandatory, but makes removal easier.)
- 3) Separate the two wire hangers on the tailpipe from the rubber mounts on the vehicle. If you have cut the tailpipe, remove the tailpipe and set aside.
- 4) Support the muffler with a stand and separate the wire hanger from the rubber mount in front of the muffler. Remove the two nuts at the muffler to converter flange connection and lower the exhaust from under the vehicle.

Installation:

- 1) Before installing anything, prep the clamps supplied in the hardware kit by removing the nuts, and applying a thick lubricant such as white grease or anti-seize to the threads.
- 2) Place inlet pipe/resonator assembly **#15113** into position behind the catalytic converter. Connect the wire hanger to its rubber mount and reinstall the factory nuts onto the flange connection. Check from the side of the vehicle to ensure the resonator is fairly flat.
- 3) Connect the inlet end of muffler **#53056** to the inlet pipe and support the muffler with a stand. Install one of the provided 3" clamps and tighten just enough to hold in position.
- 4) From the rear of the axle, slide tailpipe **#26142** into position over the rear axle and while holding the pipe, place clamp hanger **#283HA** onto the front of the pipe and slide the pipe into the muffler outlet. Connect the hanger to the rubber mount on the vehicle. Slide clamp hanger **#278HA** onto the rear of the pipe and into the rubber mount on the vehicle. The pipe should be approximately 1" away from the shock when adjusted.
- 5) Adjust the position of the muffler and pipes and tips to provide a satisfactory fit. Maintain a minimum of 3/4" clearance between the Flowmaster system, the drivetrain and chassis components, while also keeping suspension travel and vibration in mind.

6) Tighten down all clamped connections securely. After the system is secure, slide the 1/2" hanger keepers onto the end of the inlet pipe and tailpipe hangers. Slide the 7/16" hanger keepers onto the rear tailpipe and frame hangers. This will prevent the hangers from slipping out of the rubber mounts.

7) For a cleaner appearance and more secure installation, we highly recommend welding all slip-fit connections. If you live in a geographical area that has harsh winters or sees a great deal of precipitation, the use of high temperature paint over the welded areas can help to prevent surface rust and premature corrosion.



FORCE II™

Installation diagram for:
SYSTEM #17362
 1999-2005 CHEVROLET/GMC C/K 1500 TRUCKS
 4.8L & 5.3L ENGINES · EXTENDED CAB, SHORT BED

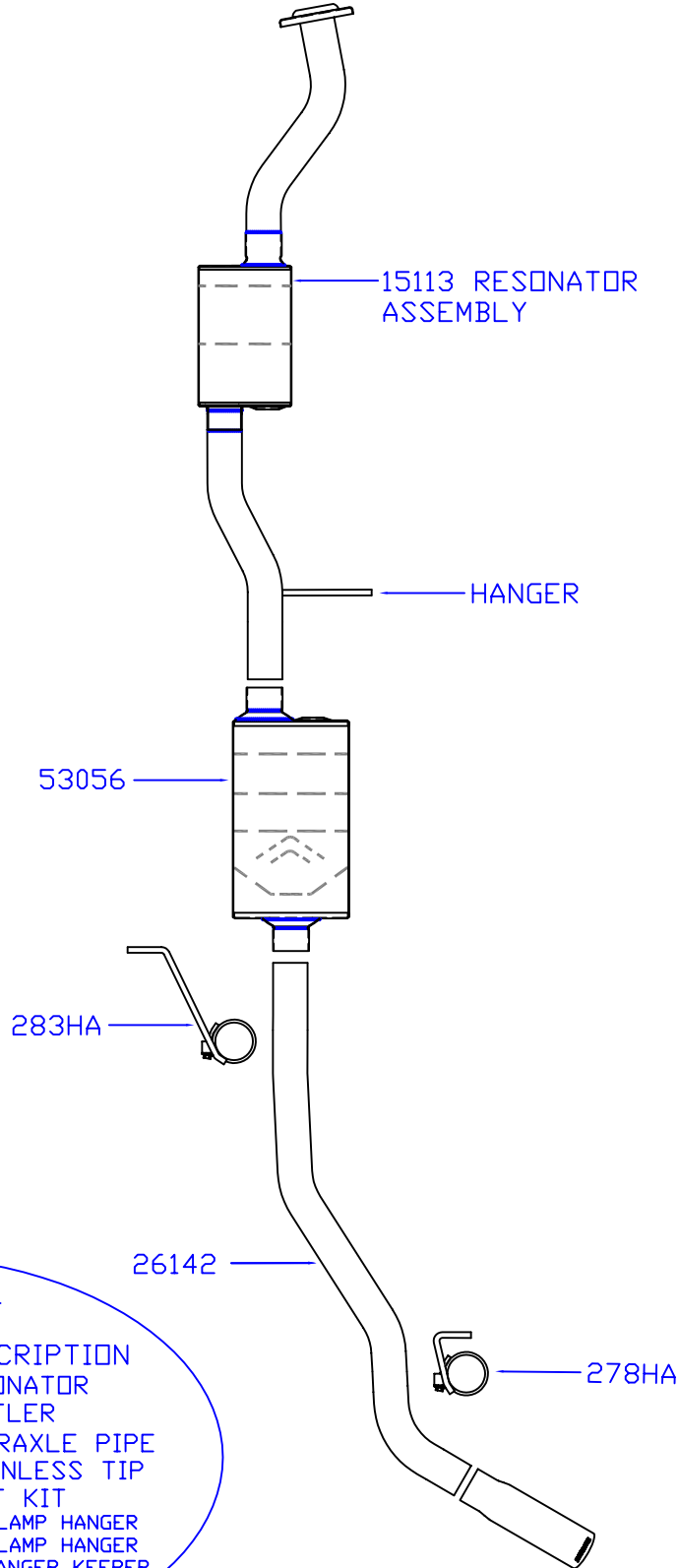

PACKING LIST

QTY.	PART#	DESCRIPTION
1	15113	RESONATOR
1	53056	MUFFLER
1	26142	OVERAXLE PIPE
1	ST429	STAINLESS TIP
1	PK406	PART KIT
1	278HA	CLAMP HANGER
1	283HA	CLAMP HANGER
3	1/2"	HANGER KEEPER
2	MC300G	3" CLAMP