



Installation Instructions For:  
**SYSTEM #17120**  
1964-1972 EL CAMINO / GMC SPRINT

**Installation:**

- 1) Raise the vehicle up on a hoist or rack to working height. If you do not have access to a hoist or rack raise the vehicle and support securely with jack stands.
- 2) On the frame of the vehicle, slightly forward of the rear axle, there are a set of two mounting holes on each side of the vehicle (use the two inner holes) which will be used to fasten the rear muffler hanger mounts. Use these stock locations to secure hanger **#298HA** (64-67) or **290HA** (68-72) on the left side and hanger **#297HA** (64-67) or **289HA** (68-72) on the right side. Use the 5/16" x 1" bolts and nuts provided. (See Diagram 1)
- 3) Slide the two rubber isolators **#HA168** onto the two hanger mounts that were installed in the previous step. Slide the two clamp hangers **#489HA** into bottom holes of the rubber isolators. The hanger rod should be inserted from the outside. Place the mufflers up into position with stands and place the outlets of the mufflers into the clamp hangers. Tighten enough to hold in place but still allow for adjustment.
- 4) Slide a clamp over each muffler inlet. Place H-pipe assembly **#16277** in its approximate position underneath the vehicle and connect the back of the H-pipe into the muffler inlets and support with a stand. Tighten clamps just enough to hold but still allow for adjustment.
- 6) Attach rubber hanger **#HA168** and mounting bracket **#238HA** to the hanger rod on the left side tailpipe **#16234**. Repeat this on the right side tailpipe using rubber hanger **#HA168** and mounting bracket **#237HA**.
- 7) Place the right tailpipe **#16235** in position over the axle on the right side of the vehicle. Place the left tailpipe **#16234** in position over the axle on the left side of the vehicle. When installing tailpipes, the rear of the vehicle must be supported by the frame with jack stands, allowing the axle to hang from the suspension. *Note: The car should be supported by the axle after the tailpipes are in place.*
- 8) Insert the tailpipes into the muffler outlets and adjust the mufflers and tailpipes into their approximate final position. Use stands to hold in position.
- 9) The front connector pipes are long enough to allow for many different header combinations, therefore, it is necessary to determine the proper length of the inlet connector pipes. Once the proper length is determined, trim the front connector pipes. To accommodate for width, cut the end of **#16293** where it enters into the H-pipe.

10) Once the pipes are cut to the proper length, raise them into position and connect them to the H-pipe and header collectors or manifold down pipes using a standard header flange of FLOWMASTER ball flanges.

11) Adjust the position of all muffler, pipes and tips to provide a satisfactory fit. Maintain a minimum of 3/4" clearance between the Flowmaster system, the drivetrain and chassis components, while also keeping suspension travel and vibration in mind.

12) Two pair of holes will now need to be drilled in the frame for the rear tailpipe mounting brackets. With the tailpipes in the desired position, locate the mounting bracket against the frame and use to mark the points to be drilled (see diagram 2). *Note: Take your time on this step – The brackets must be located in just the right position so that the tailpipes will be even.* After marking, drop the pipes and hanger out of the way and drill with 3/16" bit. Re-locate the pipes and affix brackets to the frame with the 1/4" self-tapping screws provided.

13) Adjust the position of the muffler and all pipes to provide proper fit and adequate clearance for suspension travel. Maintain a minimum of 3/4" clearance between Flowmaster system and the drivetrain and chassis components.

14) Tighten all clamped connections down securely. Install the eight 7/16" push-on hanger keepers on the round stock sticking through the rubber muffler and tailpipe hangers.

15) For a cleaner appearance and more secure installation, we highly recommend welding all slip-fit connections. If you live in a geographical area that has harsh winters or sees a great deal of precipitation, the use of temperature paint over the welded areas can help to prevent surface rust and premature corrosion.

### PACKING LIST

<u>Qty</u>	<u>Description</u>	<u>Part #</u>
2	Muffler	52558
2	Connector Pipe, (R/L)	16293
1	H- Pipe Assembly	16277
1	Tailpipe, Right	16235
1	Tailpipe, Left	16234
1	Parts kit	PK355
4	2-1/2" Clamps	MC250S
1	Tailpipe Hanger (R)	237HA
1	Tailpipe Hanger (L)	238HA
1	64-67 Hanger Mount (L)	298HA
1	64-67 Hanger Mount (R)	297HA
1	68-72 Hanger Mount (L)	290HA
1	68-72 Hanger Mount (R)	289HA
2	Clamp Hanger Assy	489HA
4	Rubber Isolator	HA168
2	5/16" x 1" Bolts	HW204
2	5/16" Nuts	HW102
2	5/16" Lock Washers	HW308
2	5/16" Flat Washers	HW302
8	Push-on hanger keepers	HW502
4	1/4" x 1" Self Tapping Screw	HW214

DIAGRAM 1

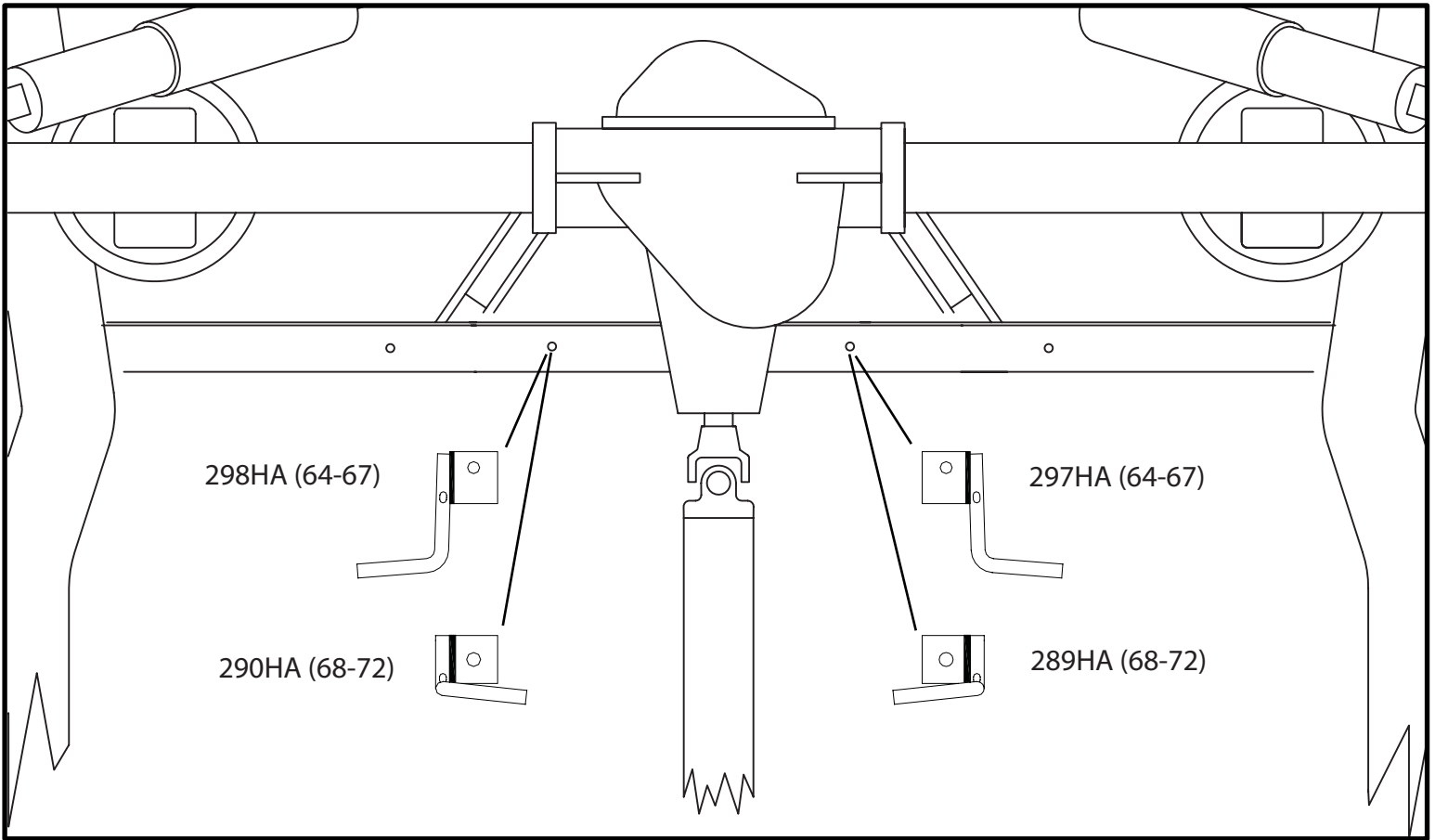
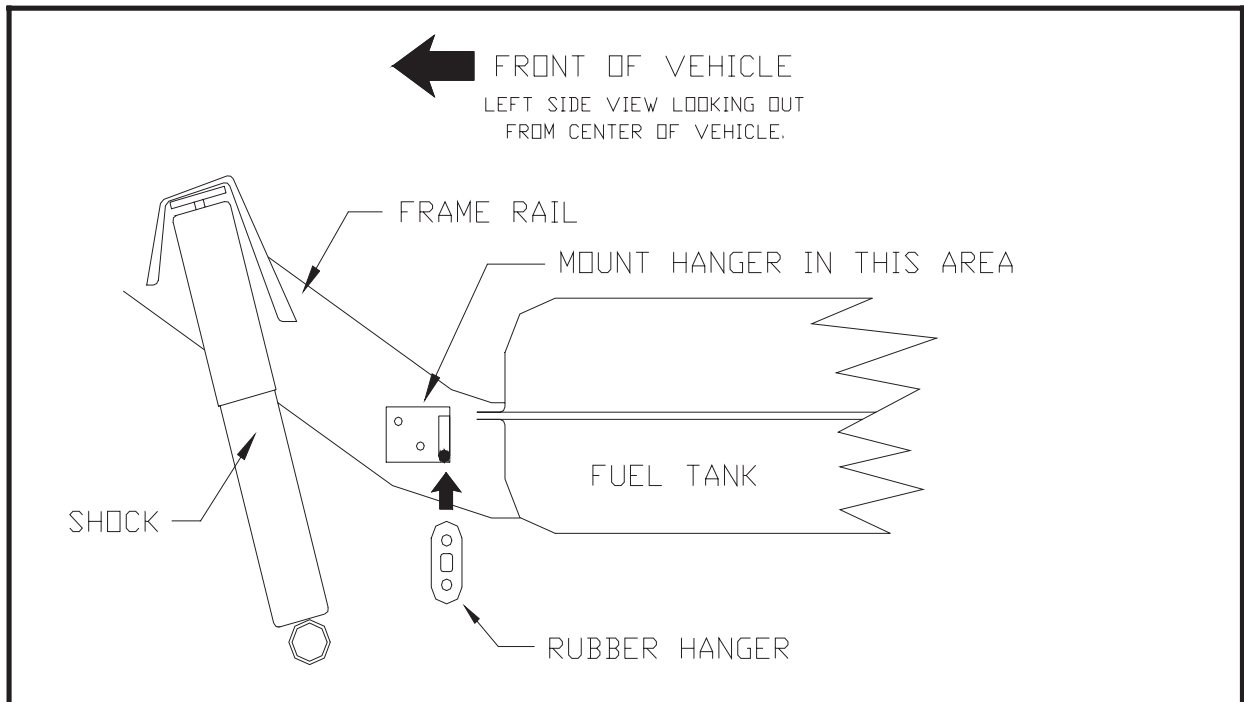

DIAGRAM 2





Installation diagram for:  
**SYSTEM #17120**  
1964-1972 EL CAMINO / GMC SPRINT

