



Black Magic S-Blade #160 & #168



Mounting Instructions:

Models #160 & #168 may be installed horizontally or vertically to the radiator. Assemble the brackets and threaded rods to the fan according to the specific application. Mount the fan with brackets using either the bolt-on or clamp-on method. **NOTE: Be sure to use star-nuts to stabilize the threaded rods. Do not over-tighten to the radiator - damage may occur.**

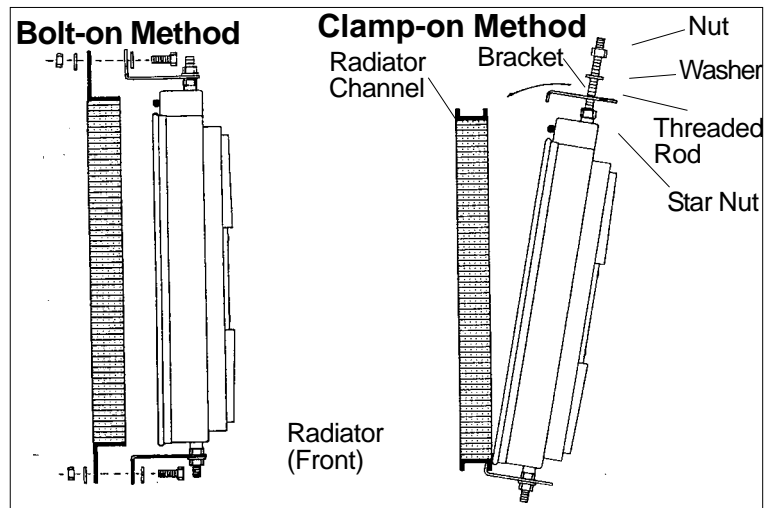

WIRING INSTRUCTIONS:

#160 with controls only

1. Disconnect the battery Negative (-) terminal
2. Connect the "B" terminal on the control to the 12 volt positive (+) battery terminal using the thick red wire and fuse holder provided in the kit.
3. Connect the "G" terminal on the control to battery negative (ground -) terminal using the thick black wire provided in the kit. (Do not install fuse at this time)
4. Connect the "+" terminal of the control box to a keyed 12 volt positive (+) power source (i.e. fuse box), using the thin red wire and fuse taps (if necessary) provided in the kit. **NOTE: Attach this wire to an ignition controlled source to stop the fan when the vehicle is shut off. Attach this wire to a constant source to keep the fan running after the vehicle is shut off.**
5. **If you have air conditioning:** With the 3-way connector provided, pass the A/C clutch positive(+) wire (connected to the A/C compressor) through the connector. Place the green wire provided into the closed end of the connector. Crimp metal plate. Snap plastic cover into place. Attach green wire to the "C" terminal of the control box. **Air Conditioning Relay activates fan when A/C is turned on**
6. Insert temp. probe through radiator core near the upper (inlet) hose. Install rubber cap over end of probe.

INSTALLATION (CONTINUED FROM PAGE 1)

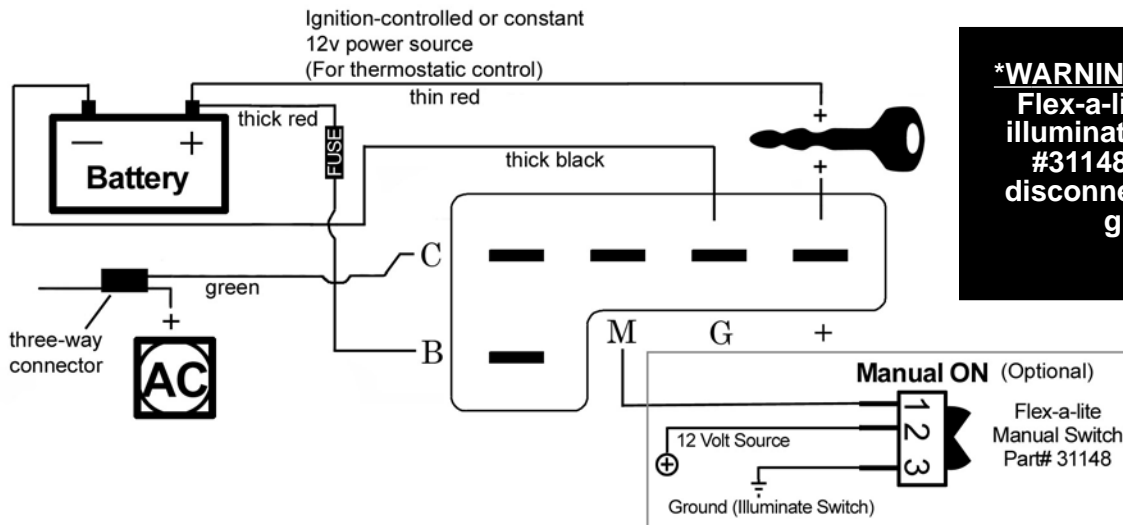

Note: To stop the fan from activating thermostatically, omit the lead to the “+” terminal of the control box. “B”, “G”, & “M” must remain connected.

ADJUSTING THE TEMPERATURE CONTROL

1. Attach the temperature control knob to the control box.
2. Turn the knob clockwise completely.
3. Idle the vehicle, observe the temperature of the vehicle. (Use the vehicles gauge)
4. When the temperature of the vehicle reaches slightly above normal, turn the control knob counter-clockwise until the fan turns on. From here on, the fan should activate at this temperature setting. Adjust as necessary according to your vehicle needs.

OPTIONAL CONNECTIONS

Manual Switch (not included) - Allows manual operation of the fan.

(This step is based on Flex-a-lite's manual switch part #31148, other switches will cause this unit to fail).

1. Connect the “M” terminal to terminal 1 on the switch.
2. Attach terminal 2 of the switch to a 12V positive (+) source.
3. Attach terminal 3 of the switch to ground, in order to illuminate the switch.

WIRING INSTRUCTIONS; #168 with out controls

1. Wire the fan motor to power source (control unit or switch and relay if desired). Connect the **Blue** wire from the fan motor to a 12v. positive (+) source. Connect the **Black** motor wire to a ground (-) source.

NOTE: Failure to do this will result in incorrect operation and damage to the fan motor!

2. **Connect an inline fuse holder:** Be shure to connect a fuse holder in-line with the positive (+) power wire to protect the fan motor and your vehicle's electrical system from damage.