

# ***FR1612 Small Block Chevy Power Steering Pump Bracket***

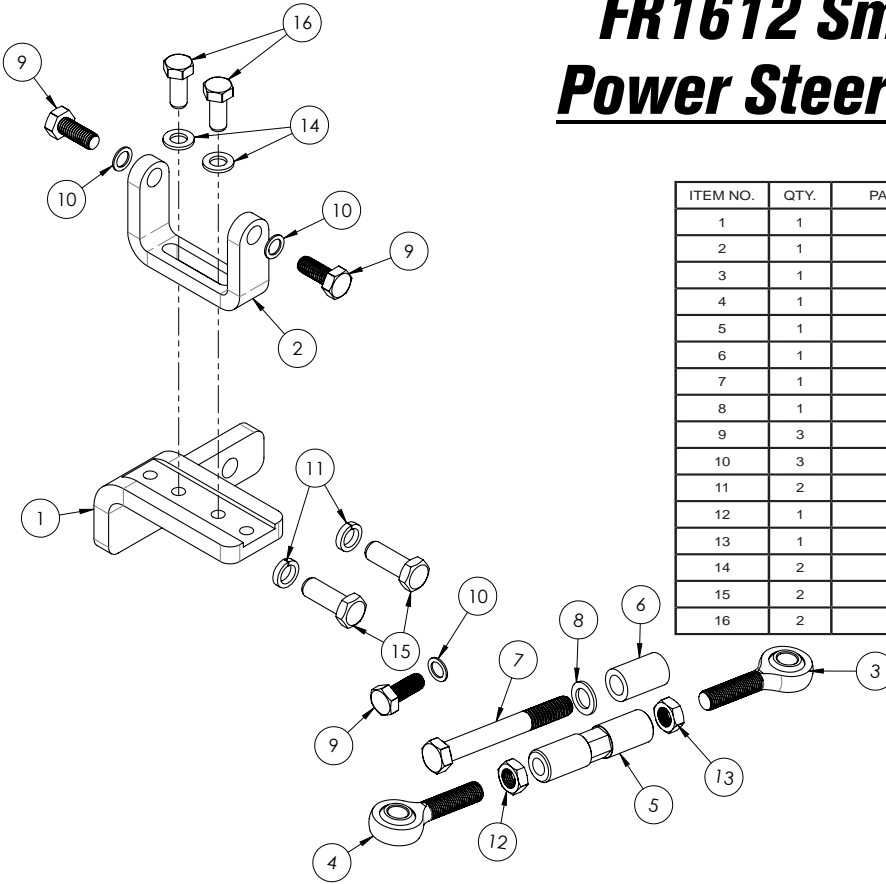

ITEM NO.	QTY.	PART NUMBER	DESCRIPTION
1	1	100632	BRACKET, MOUNT PUMP-MOTOR SB
2	1	100633	BRACKET, MOUNT PUMP PS
3	1	100667	HEIM JOINT, END ROD 3/8-24 RH
4	1	100668	HEIM JOINT, END ROD 3/8-24 LH
5	1	100720	SPACER, ADJ 0.62 X 2.52 W/ 3/8-24 RH-LH
6	1	100721	SPACER, 0.392 X 0.62 X 1.00 ALUM
7	1	100722	BOLT, 3/8-16 X 3.00 HEX HD GR8
8	1	100723	WASHER, FLAT 0.39 X 0.62 X .05
9	3	100724	BOLT, M8 X 1.25 X 20 HEX HD GR10.9
10	3	100725	WASHER, FLAT 0.32 X 0.47 X .04
11	2	100726	WASHER, LOCK SPLIT 3/8 HIGH COLLAR
12	1	100728	NUT, 3/8-24 JAM LH
13	1	100729	NUT, 3/8-24 JAM RH
14	2	100730	WASHER, FLAT 0.32 X 0.57 X .06
15	2	100779	SCREW, 3/8-16 X 1.00 HEX HD GR8
16	2	102725	SCREW, 5/16-18 X .75 HEX HD GR8



## ***Power Steering Pump Installation/Small Block Chevy***



Install L-shaped bracket (1) on engine with bolts (15) and lockwashers (11) supplied



Install pump bracket (2) to L-shaped bracket (1) with bolts (16) and washers (14) supplied



Install pump to bracket (2) using bolts (9) and washers (10) supplied

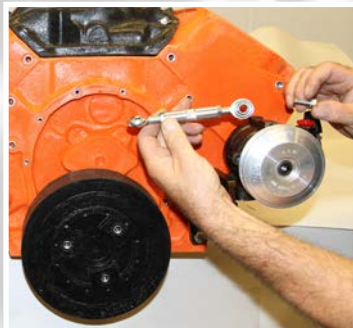

Install adjuster to pump using bolt (9) and washer (10) supplied



Remove upper water pump bolt. Install spacer (6) and adjuster with bolt (7) and washer (8) supplied