

# PROTECT YOUR FLEET

**BATTERY CONTROL SAFETY SYSTEMS**

# *The* **BIG SWITCH** **5000**

**500 AMP KILL SWITCH**

**FLAMING<sup>®</sup>  
RIVER**  
HEAVY-DUTY ELECTRICAL



## **500 Amp Battery Disconnect Switch:**

**FR1046** *The Big Switch 500 with Lock-Out Bracket*

**FR1046LED** *The Big Switch 500  
with Lock-Out Bracket & LED Indicator*

**FR1047** *The Big Switch 500 Lock-Out Hole  
with Lever Handle w/ Retrofit Diamond Bracket*

<b>Voltage</b>	<b>12V/24V</b>
<b>Max Continuous Current</b>	<b>500 Amps</b>
<b>Environmental Protection Rating</b>	<b>IP65</b>
<b>Corrosion Resistant</b>	<b>Yes</b>
<b>Operating Temperature</b>	<b>-40°F to + 176°F (-40°C to +80°C)</b>
<b>Switch Body Material</b>	<b>Glass-filled nylon</b>
<b>Internal Contacts</b>	<b>AgSnO2 (Silver Tin Oxide) Plated Copper</b>
<b>Contact Terminals</b>	<b>AgSnO2 (Silver Tin Oxide) Contacts</b>
<b>Stud Diameter</b>	<b>M10</b>
<b>Available Stud Length</b>	<b>1.18 in (1-3/16 in)</b>
<b>Contact Hardware</b>	<b>Nickel-plated brass</b>
<b>M10 Tightening Torque</b>	<b>11-13 ft-lbs</b>

### **Switch Features**

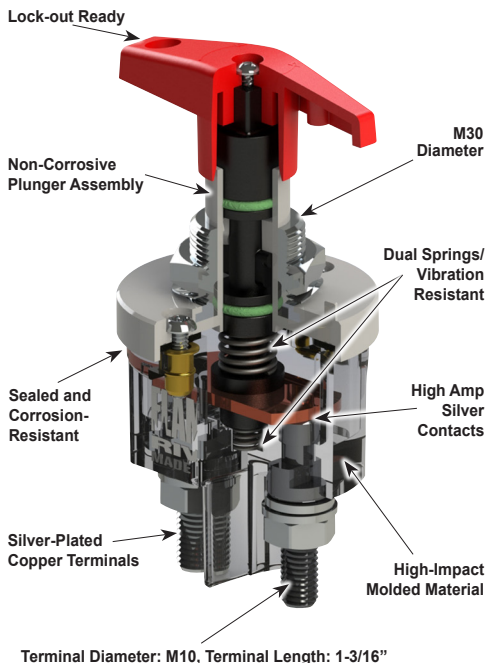

**To activate switch,  
push handle down  
while turning**

**Note: Terminals on battery disconnect switches are live parts of the electrical system and should be treated just like battery terminals. Terminal covers are recommended, but not included, for each kit. Always verify with your vehicle manufacturer for correct installation and switch location to avoid any damage to electrical system and/or vehicle warranty.**

## Kit Contents (Varies based on part number)

Item No.	Description	Qty
1.....	Switch Assembly .....	1
2.....	Switch Bracket.....	1
3.....	Switch Handle/Screw.....	1
4.....	Off/On Logo Tag.....	1
5.....	Wave Washer .....	1
6.....	M30 Hex Nut .....	1
7.....	1/4" -20 x 7/8" Hex Cap Screw .....	2
8.....	1/4" Flat Washer .....	2
9.....	1/4"-20 Nylock Nut .....	2
10.....	Hex Nut for Terminal Stud.....	2
11.....	Lock Washer for Terminal Stud.....	2
12.....	Flat Washer for Terminal Stud .....	2

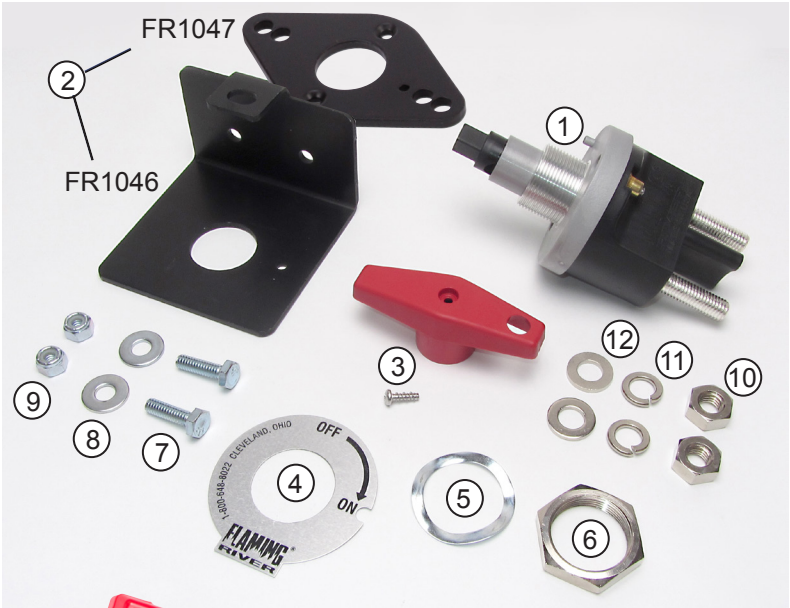

(Lock  
not included)



FR1046



FR1047



FR1046LED

## Switch and Bracket Assembly

(Refer to diagrams on following page)

### **FR1046/FR1046LED**

1. Place the red T-handle (A) on top of the switch (F) and turn clockwise to turn the switch ON and remove the T-handle.
2. Remove the M30 hex nut (C) and wave washer (B) from the packaging.
3. Insert the neck of the switch (F) into the mounting bracket hole (E) and slide on the ON/OFF plate (D), wave washer (B), and M30 hex nut (C).
4. Tighten the hex nut (C) until the wave washer (B) is completely flat. Do not tighten the nut more than 7-10 ft.·lbs. Make sure the tab on the gray switch (F) top fits into the small alignment hole. The top of the gray switch (F) should be flush against the bottom of the bracket (E).
5. Install the T-handle (A) on the shaft of the switch. Insert and tighten the Phillips head screw into the handle. Rotate the switch to the OFF position by turning the handle counter-clockwise.

### **FR1047**

1. Diamond bracket is already properly installed on your FR1047 Battery Disconnect Switch.
2. Using the information in figure 2, determine the desired mounting hole width: either 3.15" (80 mm) or 3.94" (100 mm) spacing.
3. Install the switch in the vehicle and the lever style handle (G) onto the top of the switch shaft with the supplied phillips head screw.

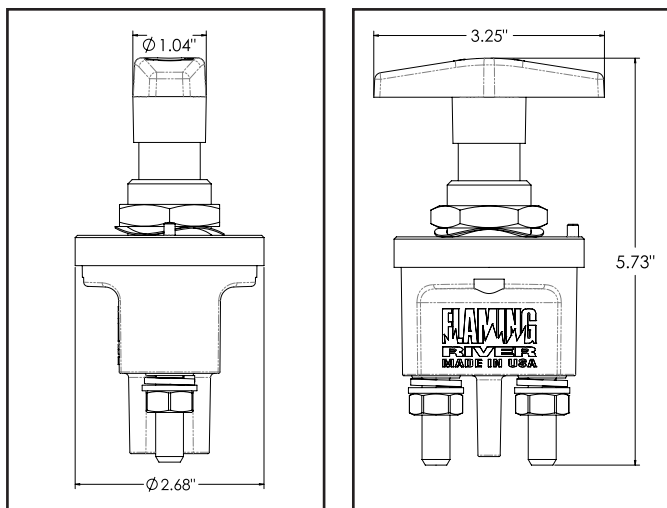

## Switch and Bracket Assembly (cont.)

**Figure 1 (Lock-Out Bracket)**

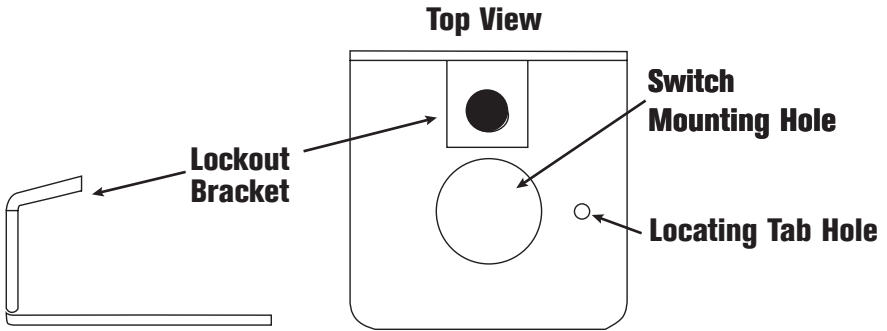

**Figure 2 (Diamond Bracket)**

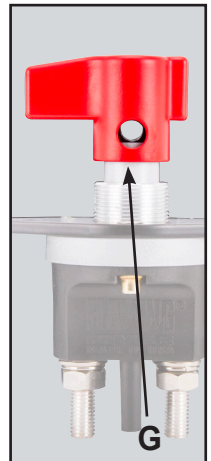
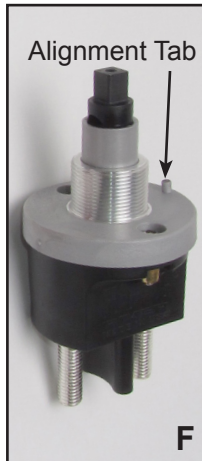
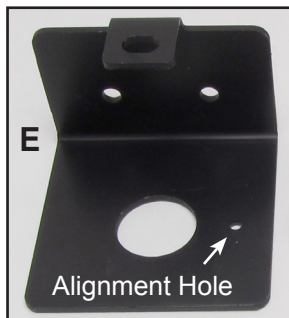
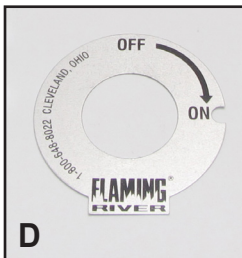
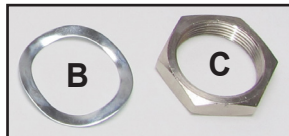
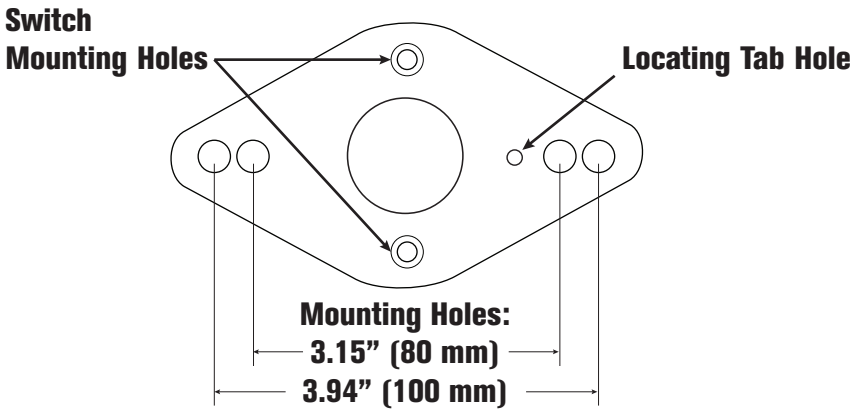

## **Electrical Connections**

Make sure you have properly mounted the switch with the included attachment hardware before installing cables, wiring, or making electrical connections. Remove the positive and negative cables connected to the battery before proceeding. This is for the installer's safety. No part of the vehicle should be energized while installing the switch. The Big Switch 500 Series battery disconnect switches can be used to disconnect either the positive or negative terminals of the battery. **Verify installation and wiring with the vehicle's manual and follow all vehicle manufacturer instructions.**

1. Select two battery cables of required length for the installation. Cable gauge size will be at the installer's discretion depending on vehicle requirements and specifications. If the installer wishes to cut and reuse the original battery cable, make sure that there is enough cable to reach the switch without stressing the cable or the battery disconnect switch.
2. Attach the two cable ends to the switch terminals as shown in below. Tighten the M10 nuts until the lock washers flatten, but no tighter than 11-13 ft.·lbs.
3. Once the cables are installed and tightened, terminals covers (recommended, but not included) should be applied to the switch terminals.
4. Make sure the The Big Switch 500 is turned to the OFF position. Connect the load-side cable to the required point on your vehicle FIRST. Hook up the cable that connects directly to the battery terminals SECOND. See below for clarification.
5. Turn ON The Big Switch 500 and make sure your vehicle is powered.



### **FR1003TM Terminal Covers**

Sold in sets of two. Can be used to cover cables on all Battery Disconnect Switches. Sold separately from switch.

## LED Indicator Wiring Instructions (FR1046LED Only)

Connection of the LED indicator should be completed at the time the switch is mounted but before battery cables are connected to the switch. Do not install the switch or LED indicator while the vehicle battery is connected to the vehicle. Make sure that the area of the chassis where the bracket is mounted has a good connection to ground and is not insulated by plastic or paint. If this is not possible, an additional wire should be run directly to the WHITE ground wire to complete the circuit.

1. Make sure that the switch is installed in the bracket and mount the switch in the desired location. Only screw on ONE of the lock nuts.
2. Take the WHITE wire with the smaller eyelet and slide it over the right screw. Tighten down the right lock nut so that the eyelet is pressed firmly against the vehicle chassis for a proper ground connection.
3. Take the BLACK wire with the large eyelet and slide it over the screw terminal that is connected to the VEHICLE LOAD.
4. Before proceeding, make sure the battery disconnect switch is in the OFF position.
5. Connect the vehicle load side battery cable, followed by the battery side battery cable, and secure these connections with the provided M10 washers, lock washers, and nuts.
6. Connect your battery cables to the positive and negative battery terminals and test your newly installed switch.

