

WARNING:

Do not inflate this assembly when it is unrestricted. The assembly must be restricted by the suspension or other adequate structure. Do not inflate beyond 100 psi. Improper use or over inflation may cause property damage or severe personal injury.

INSTALLATION INSTRUCTIONS

Congratulations—your new Air Helper Springs are quality products capable of improving the handling and comfort of your vehicle. As with all products, proper installation is the key to obtaining all of the benefits your kit is capable of delivering. Please take a few minutes to read through the instructions to identify the components and learn where and how they are used. It is a good idea to start by comparing the parts in your kit with the parts list below.

The heart of the air helper spring kit is, of course, the air springs. Remember that the air helper springs must flex and expand during operation, so be sure that there is enough clearance to do so without rubbing against any other part of the vehicle.

Be sure to take all applicable safety precautions during the installation of the kit. The instructions listed in this brochure and the illustrations all show the left, or driver's side of the vehicle. To install the right side assembly simply follow the same procedures.

Your kit includes separate inflation valves and air lines for each air helper spring. This will allow you to level your vehicle from side to side as well as from front to back. If you would rather have a single valve inflation system, your dealer can supply the required "T" fitting.

IMPORTANT!

For your safety and to prevent possible damage to your vehicle, do not exceed the maximum load recommended by the vehicle manufacturer (GVWR). Although your Air Helper Springs are rated at a maximum inflation pressure of 100 psi, this pressure may allow you to carry too great a load on some vehicles. It is best to have your vehicle weighed once it is completely loaded and compare that weight to the maximum allowed. Check your vehicle owner's manual or data plate on driver's side door for maximum loads listed for your vehicle.

When inflating your Air Helper Springs, add air pressure in small quantities, checking pressure frequently during inflation. The air spring requires much less air volume than a tire and, therefore, inflates much quicker.

PARTS LIST

AIR SPRING	9055	2
UPPER BRACKET	5771	2
LEFT FRAME BRACKET	5701	1
RIGHT FRAME BRACKET	5700	1
LEFT LOWER BRACKET	5791	1
RIGHT LOWER BRACKET	5790	1
FRAME HOLE BRACKET	5660	4
BAIL CLAMP 4.5 X 2.5 X 2.0	3410	4
AIR LINE TUBING 18 FT.		1

BOLT PACK (A21-760-2565)

INFLATION VALVE	3032	2
ELBOW FITTING	3048	2
3/8"-16 FLANGE LOCK NUT		16
3/8"-16 X 1" HEX HEAD BOLT		12
3/8"-16 X 1/2" FLANGE BOLT		4
M10 X 20 MM BOLT		2
5/16" FLAT WASHER		4
THERMAL SLEEVE		2
NYLON TIE STRAP		6
CAUTION TAG		2

Figure "A"

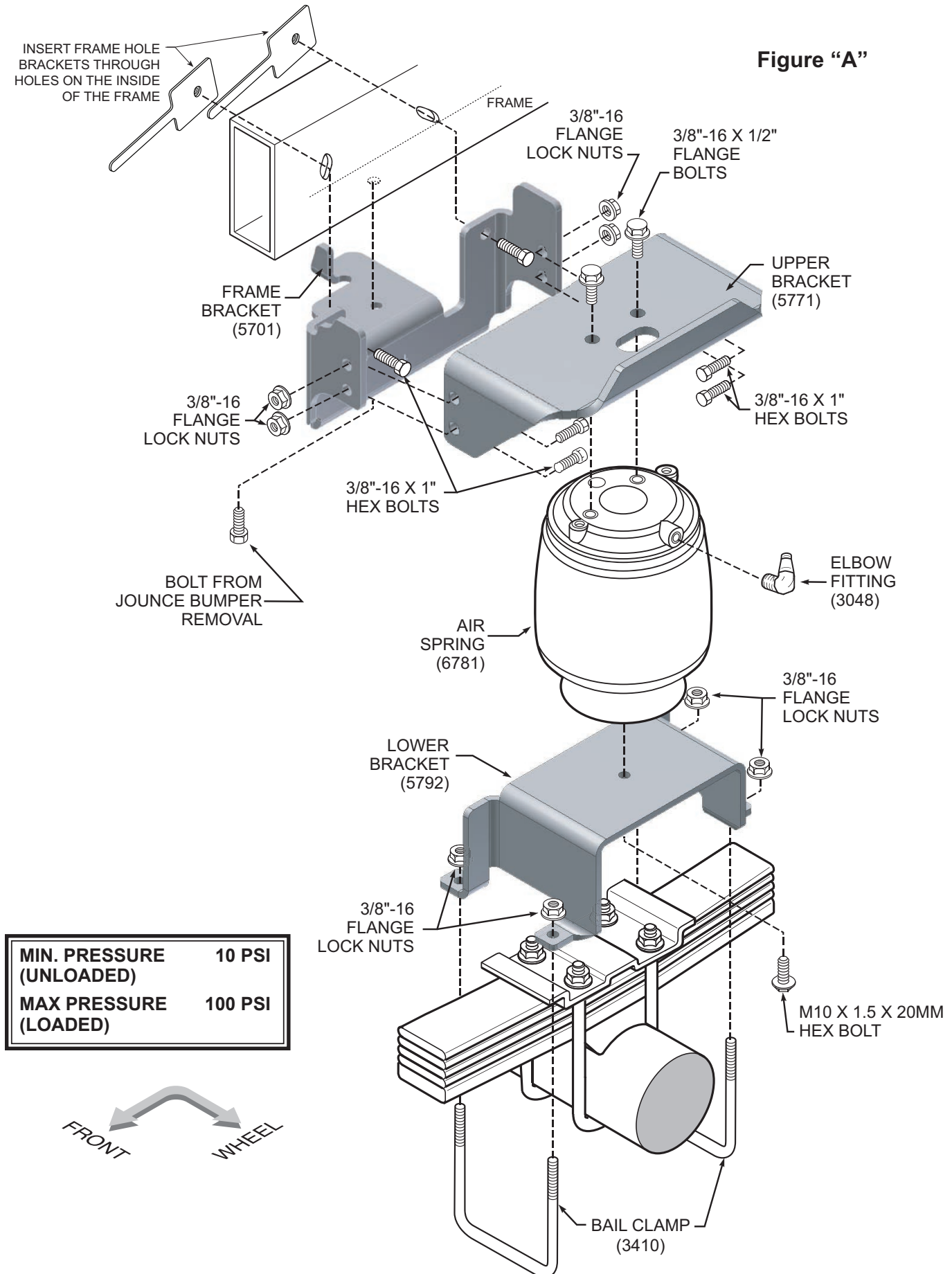

STEP 1 — PREPARE THE VEHICLE

With the vehicle on a solid, level surface, chock the front wheels. Raise the vehicle by the rear axle and set on jack stands rated for your vehicles weight. Remove the rear wheels. Remove the jounce bumpers from the under side of the frame rail. The jounce bumper will not be re-used with the kit, but the bolt will be re-used.

STEP 2 — ATTACH THE UPPER BRACKET

Select one air helper spring and one upper bracket from your kit. Fasten the upper bracket to the air spring using the 3/8"-16 X 1/2" flange bolts, **see Figure "A"**. Install the elbow fitting into the air spring. Tighten the air fitting securely to engage the orange thread sealant. Position the fitting to point to the anticipated location of the air inflation valves.

STEP 3 — ATTACH THE LOWER BRACKET

Select the left lower bracket and fasten it to the air spring with a M10 X 1.5 X 20MM hex bolt (finger tight). **Figure "B"**.

STEP 4 — ATTACH THE FRAME BRACKET TO THE FRAME

Attach the left frame bracket to the bottom of the frame reusing the jounce bumper bolt in the hole from the jounce bumper removal. Next, insert the 3/8"-16 x 1" hex head bolts through the left frame bracket and into the holes on the outside of the frame. Secure with frame hole brackets inserted through the hole on the inside of the frame. **See Figure "A"**. **DO NOT OVER TIGHTEN! 20 FT/LBS Max.**

STEP 5 — INSTALLING THE ASSEMBLY TO THE VEHICLE

Place the assembly on the leaf stack over the spring retainer and align the holes in the upper bracket with the holes in the left frame bracket. Install four, 3/8" x 1" hex head bolts and fasten using 3/8"-16 flange nuts. Secure the left lower bracket to the leaf stack using bail clamps and 3/8"-16 flange nuts. Once aligned, tighten the bolt holding the bottom of the air spring to the lower bracket. **See Figures "A" & "B"**

STEP 6 — INSTALLATION TO THE PASSENGER'S SIDE ASSEMBLY

Reverse any orientations when assembling and installing the right, or passenger, side of the vehicle.

STEP 7 — INSTALL THE AIR LINE AND THE INFLATION VALVE

Uncoil the air line tubing and cut it into two equal lengths. **DO NOT FOLD OR KINK THE TUBING.** Try to make the cut as square as possible. Insert one end of the tubing into the elbow fitting installed in the top of the air helper spring. Push the tubing into the fitting as far as possible. Select a location on the vehicle for the air inflation valves. The location can be on the bumper or the body of the vehicle, as long as it is in a protected location so the valve will not be damaged, but maintain accessibility for the air chuck, **see Figure "D"**. Drill a 5/16" hole and install the air inflation valve using two 5/16" flat washers per valve as supports, **see Figure "C"**. Run the tubing from the air helper spring to the inflation valve, routing it to avoid direct heat from the engine, exhaust pipe, and away from sharp edges. Thermal sleeves have been provided for these conditions. If a thermal sleeve is required simply slide the sleeve over the air line tubing to the location requiring protection. The air line tubing should not be bent or curved sharply as it may buckle. Secure the tubing in place with the nylon ties provided. Push the end of the air line tubing into the inflation valve as illustrated, **see Figure "C"**.

STEP 8 — CHECK THE AIR SYSTEM

Once the inflation valves are installed, inflate the air helper springs to 70 psi and check the fittings for air leaks with an applied solution of soap and water. If a leak is detected at a tubing connection then check to make sure that the tube is cut as square as possible and that it is pushed completely into the fitting. The tubing can easily be removed from the fittings by pushing the collar towards the body of the fitting and then pulling out

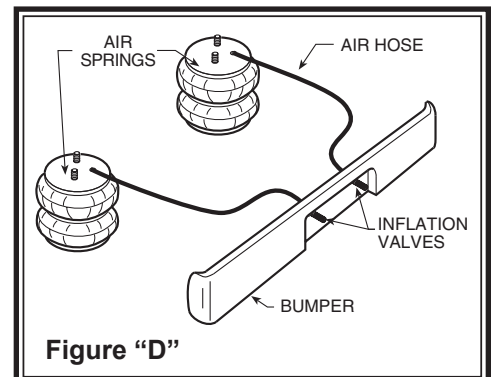
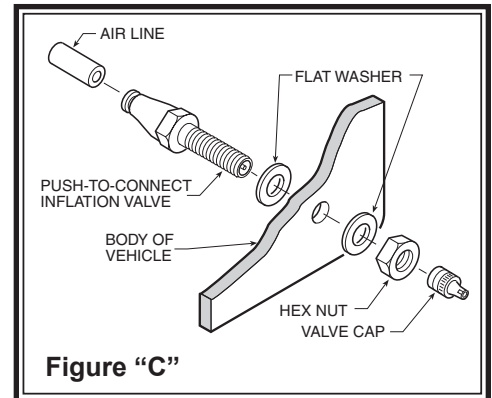
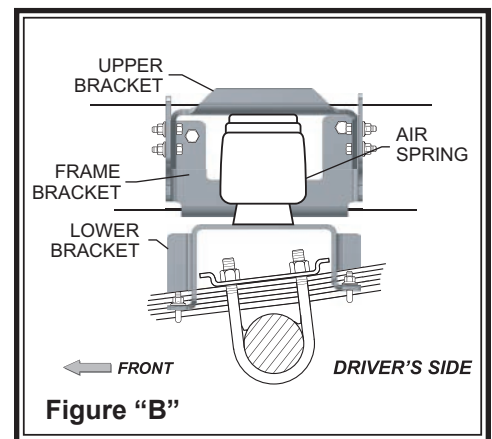

the tube. If a leak is detected where the fitting screws into the spring, screw the fitting into the air spring until the leak stops. Reinstall the tubing and reinflate the air springs and check for leaks as noted above.

This now completes the installation. Install the wheels and torque the lug nuts to the manufacturer's specifications. Raise the vehicle by the rear axle and remove the jack stands and lower the vehicle back onto the ground. Re-attach the negative battery cable and remove the wheel chocks from the wheels. Before proceeding, check once again to be sure you have proper clearance around the air springs. With a load on your vehicle and the air helper springs inflated, you must have at least 1/2" clearance around the air springs. As a general rule, the air helper springs will support approximately 40 lbs. of load for each psi of inflation pressure (per pair). For example, 50 psi of inflation pressure will support a load of 2000 lbs. per pair of air helper springs. **FOR BEST RIDE** use only enough air pressure in the air helper springs to level the vehicle when viewed from the side (front to rear). This amount will vary depending on the load, location of load, condition of existing suspension and personal preference.

NOTE:

*Too much air pressure in the air helper springs will result in a firmer ride, while too little air pressure will allow the air helper spring to bottom out over rough conditions. Too little air pressure will also not provide the improvement in handling that is possible. **TO PREVENT POSSIBLE DAMAGE MAINTAIN A MINIMUM OF 10 psi IN THE AIR HELPER SPRINGS AT ALL TIMES.***

Once the air helper springs are installed, it is recommended that the vehicle not be lifted by the frame, as over-extension may occur, resulting in damage to the air helper springs. However, should it become necessary to raise the vehicle by the frame, deflate both air helper springs completely.

NOTE:

MIN PRESSURE	10 PSI
MAX PRESSURE (LOADED)	100 PSI



No Drill Inflation Valve Bracket

Parts List

Description	Part Number	Quantity
Inflation Valve Bracket	9483	1
Large Nylon Tie	9488	2

This bracket is designed to mount on receiver hitches round or square. Simply use the two provided large Nylon ties to affix the bracket to the receiver hitch tube. Install the air inflation valves on the bracket using two 5/16" flat washers per valve as supports. Then push the end of each air line tubing into the inflation valve as far as possible.

