



INSTALLATION INSTRUCTIONS

Read installation instructions in its entirety before installing your Coil-Rite Kit

WARNING

Do not inflate this assembly when it is unrestricted. The assembly must be restricted by a coil spring. Do not ever inflate beyond recommended operating pressures for your specific vehicle. Improper use or over inflation may cause property damage or severe personal injury.

**Firestone Industrial Products
Carmel, Indiana, USA**

NOTE 1:

Some Ford, Lincoln, and Mercury vehicles have a rubber sleeve inside the rear coil spring. This sleeve needs to be removed to allow installation of the air spring. It can be either cut out or pulled out with vise grips.

NOTE 2:

On Volvo vehicles a 3/8" hole will have to be drilled in the upper spring seat to allow the air line to pass through. See Figure "A".

PARTS LIST

| DESCRIPTION | QTY. |
|------------------------------------|------|
| AIR SPRINGS | 2 |
| PLUG | 2 |
| 18' AIR LINE | 1 |
| NYLON TIE | 6 |
| PUSH-TO-CONNECT INFLATION VALVE | 2 |
| 5/16" FLAT WASHER | 4 |
| THERMAL SLEEVE | 2 |
| PROTECTOR | 2 |

STEP 1 - VEHICLE PREPARATION

Remove the positive battery cable. With the vehicle on a solid level surface chock the front wheels. Raise the rear wheels of the vehicle using a lift or platform jack rated for your vehicle weight. Remove the rear wheels. Lower the vehicle onto jack stands rated for your vehicles weight making sure the suspension is fully extended. (Do NOT use wood or concrete blocks to support the weight of the vehicle.)

STEP 2 - SHOCK ABSORBERS

If necessary, additional clearance between the coil spring turns may be obtained by removing the shock absorbers from the lower mounts and lowering the suspension an additional one to two inches. (CAUTION: Do not put strain or tension on the flexible brake line.)

STEP 3: AIR SPRING PREPARATION

Cut a section of air line tubing 3 inches in length and install into the push-to-connect fitting on the air spring (a "saw" cut with a sharp knife is preferred). Exhaust the air from the air spring by rolling it up toward the air inlet. After the air is exhausted, install the plug into the 3" tubing coming out of the air spring see Figure "B".

Proceed with Step 3 for the following vehicles;

Century, Celebrity, Cutlass Ciera 6000 and X, Skylark, Citation, Omega, Phoenix, Pathfinder, Trooper, Toronado, Riviera, El Dorado, Seville, LeSabre, Electra, Park Avenue, DeVille, Olds 88, Olds 98, Bonneville, Volvo, and Ford, Lincoln, and Mercury vehicles.

REFER TO STEP 4 FOR VEHICLES NOT MENTIONED ABOVE.

RECOMMENDED OPERATING PRESSURES

| | |
|----------------|---------------|
| Passenger Cars | 5 - 35 p.s.i. |
|----------------|---------------|

COIL-RITE INSTALLATION PROCEDURE

STEP 3A - INSTALL THE AIR SPRING

(Century, Celebrity, Cutlass Ciera 6000 and X, Skylark, Citation, Omega, Phoenix, Pathfinder, Trooper, Volvo, and Ford, Lincoln, and Mercury vehicles)

Insert the top of the flattened air spring into the coil spring through the lowest opening in the coil spring with the push-to-connect air inlet at the top of the coil spring see Figures "C" & "D". The air spring supports will be added in Step 3D.

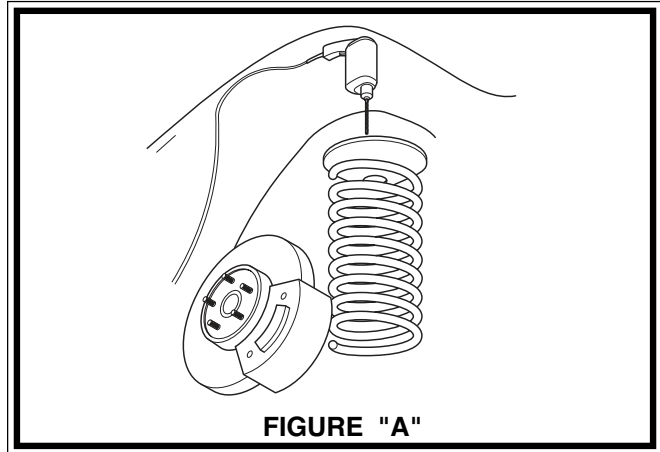

STEP 3B - INSTALL THE AIR SPRING

(Toronado, Riviera, El Dorado, Seville, LeSabre, Electra, Park Avenue, DeVille, Olds 88, Olds 98, And Bonneville)

Insert the top of the flattened air spring into the coil spring through the lowest opening in the coil spring with the push-to-connect air inlet at the bottom of the coil spring see Figures "E" & "F". The air spring supports will be installed in Step 3D.

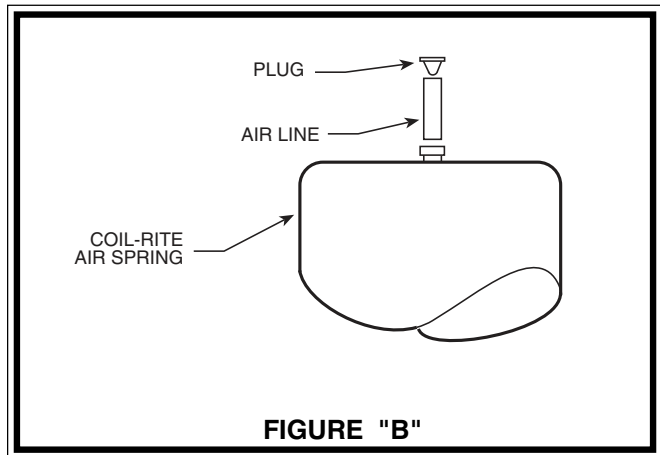

STEP 3C - ADJUST THE AIR SPRING

Push the air spring up into the coil spring by hand or with a blunt tool, such as a spoon shaped tire iron. Do NOT use any thing with sharp edges or corners, as this may damage the air spring.

When the air spring is completely within the coil spring, remove the plug and tubing section by pushing the collar on the fitting towards the air spring and pulling on the tubing to remove. Allow the air spring to return to its normal shape.

STEP 3D - INSTALL THE SUPPORTS

(Century, Celebrity, Cutlass Ciera 6000 and X, Skylark, Citation, Omega, Phoenix, Pathfinder, Trooper, Volvo, and Ford, Lincoln, and Mercury vehicles)

Push the air spring to the bottom of the coil spring and insert the protector between the air spring and the top spring seat see Figure "D".

(Toronado, Riviera, El Dorado, Seville, LeSabre, Electra, Park Avenue, DeVille, Olds 88, Olds 98, and Bonneville)

Push the air spring to the top of the coil spring and insert the protector between the air spring and the bottom spring seat see Figure "F".

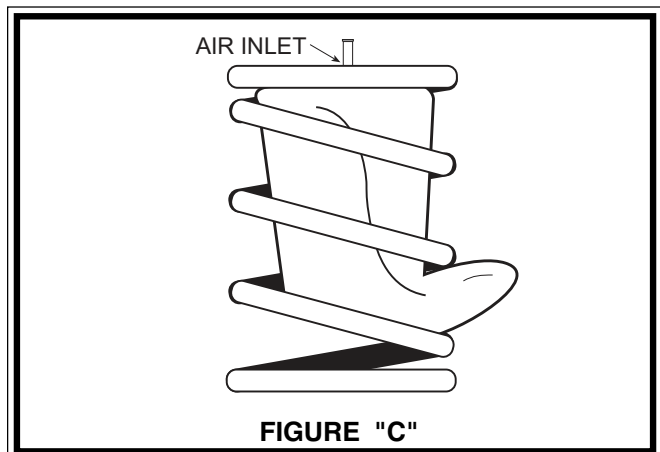

REPEAT STEP 3 FOR THE OPPOSITE SIDE OF THE VEHICLE

PROCEED TO STEP 5 TO COMPLETE INSTALLATION

PLEASE TAKE ALL NECESSARY SAFETY PRECAUTIONS WHEN INSTALLING YOUR COIL-RITE KIT.

COIL-RITE INSTALLATION PROCEDURE

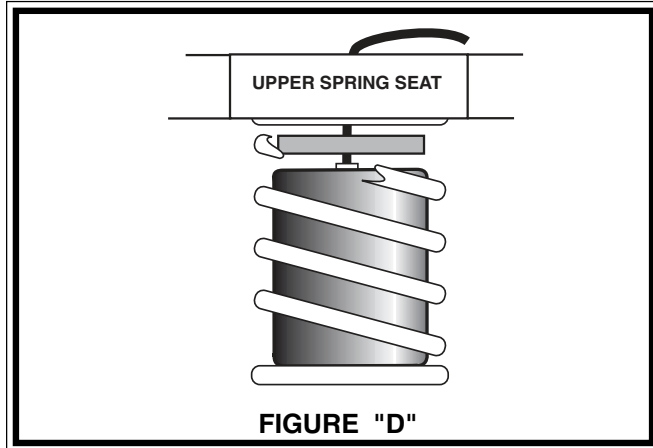

STEP 4A- PREPARE THE VEHICLE FOR INSTALLATION
(Camaro, Firebird, Monza, Skyhawk, Starfire, Astre, Sunbird, and Vega)

NOTE 1:

Remove the coil spring and spring insulator from the vehicle. Insert the air spring into the coil spring with the push-to-connect air fitting at the bottom of the coil spring see Figure "E" & "F".

NOTE 2:

The vehicles in this section do not have a hole in the lower spring seat. Locate the center of the lower spring seat and mark with a center punch. Drill a 3/8" hole through the center of the lower spring seat.

NOTE 3:

On the 1975 and newer Vega, Monza, Starfire, Skyhawk, and Sunbird the upper jounce bumper cone will need to be removed. The air spring will take the place of the jounce bumper cone.

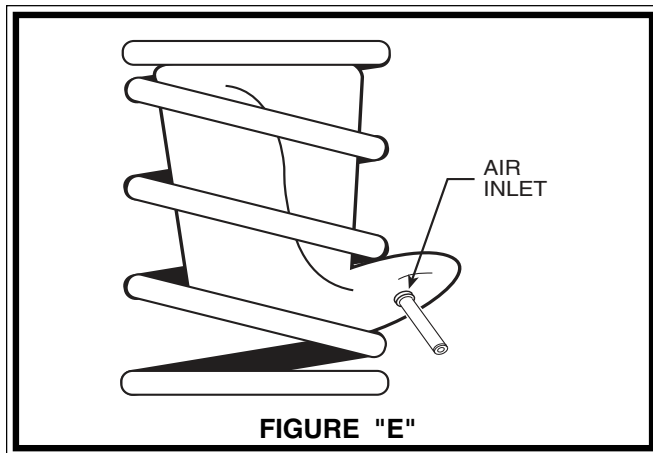

STEP 4B - RE-INSTALL THE ASSEMBLY

Re-install the upper spring insulator on the top of the coil spring. Index it so that the notch fits on the end of the coil spring. Re-install the coil spring and the air spring assembly into the vehicle's spring seats, ensuring that the end of the coil spring is indexed properly into the notch in the spring seat.

STEP 4C - INSTALL THE SUPPORTS

Push the air spring to the top of the coil spring and insert the protector on the bottom of the air spring (air fitting end) see Figure "F".

REPEAT STEP 4 FOR THE OPPOSITE SIDE OF THE VEHICLE

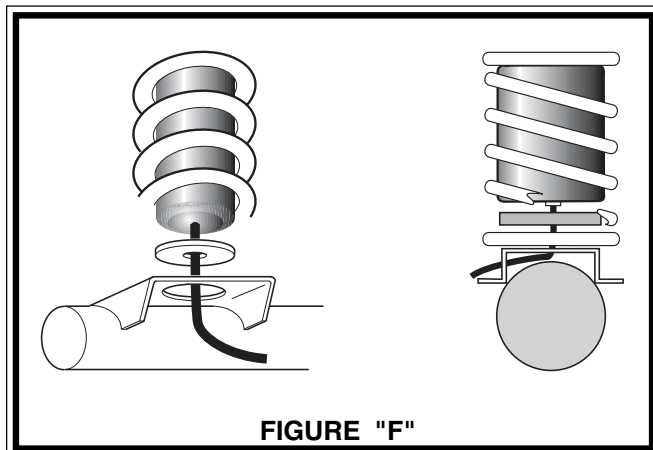

STEP 5 - RE-ATTACH THE SHOCK ABSORBERS

Attach the shock absorbers if removed earlier in the installation.

STEP 6 - ROUTE THE AIR LINE

Cut the air line tubing into two equal lengths, making sure the tubing is cut as squarely as possible (a "saw" cut with a sharp knife is preferred). Select a location for the inflation valves in a protected area, such as: on the bumper or body (Note: The inflation valve will be installed in step 7).

Insert the air line tubing into the push-to-connect fitting on the air spring as far as possible. Route the air line

NOTE: CHECK AIR PRESSURE ON A MONTHLY BASIS.

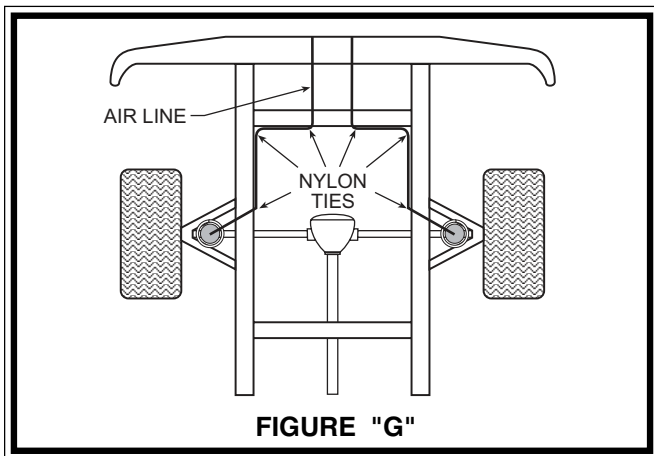

from the air spring to the desired inflation valve location. With the tubing routed from the air spring to the location of the inflation valve use, the nylon ties supplied to secure the air line tubing to the vehicle as shown in *Figure "G"*. Be careful to avoid areas of high heat and sharp edges when fastening the tubing to the vehicle.

STEP 7 - INSTALL THE INFLATION VALVE

Drill a 5/16" hole where you wish to mount the inflation valve. Remember to keep the inflation valve in a protected area that is easily accessible. Attach the inflation valve to the bumper or body of the vehicle as shown in *Figure "H"*. Tighten all nuts at this time.

Cut the excess air line tubing so that it will fit easily into the inflation valve, making sure the end is cut squarely (a "saw" cut with a sharp knife is preferred). Push the end of the tubing into the inflation valve as far as possible.

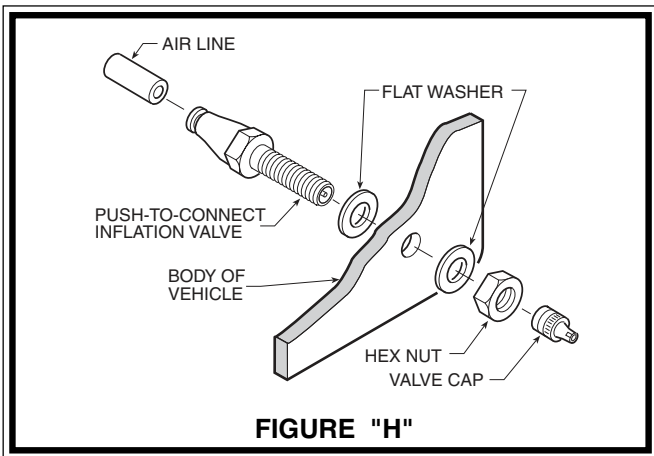

STEP 8 - INFLATE AND TEST

Inflate the air springs to recommended maximum operating pressure (see page 1 for operating pressures). With a soap and water solution, check for air leaks around the fittings and valve core. We recommend inflating and deflating in small increments to find the ideal riding condition for your vehicle.

STEP 9 - COMPLETION

Installation is now complete. Replace the wheels and torque the lug nuts to the manufacturer's specification. Raise the vehicle and remove the jack stands and lower the vehicle to the ground. Re-attach the positive battery cable.