

## **WARNING:**

Do not inflate this assembly when it is unrestricted. The assembly must be restricted by the suspension or other adequate structure. Do not inflate beyond 100psi. Improper use or over inflation may cause property damage or severe personal injury.

## **INSTALLATION INSTRUCTIONS**

Congratulations - your new Air Helper Springs are quality products capable of improving the handling and comfort of your vehicle. As with all products, proper installation is the key to obtaining all of the benefits your kit is capable of delivering. **Please take a few minutes to read through the instructions to identify the components and learn where and how they are used.** It is a good idea to start by comparing the parts in your kit with the parts list below.

The heart of the air helper spring kit is, of course, the air springs. Remember that the air helper springs must flex and expand during operation, so be sure that there is enough clearance to do so without rubbing against any other part of the vehicle.

Be sure to take all applicable safety precautions during the installation of the kit. The instructions listed in this brochure and the illustrations all show the left, or driver's side of the vehicle. To install the right side assembly simply follow the same procedures.

Your kit includes separate inflation valves and air lines for each air helper spring. This will allow you to level your vehicle from side to side as well as from front to back. If you would rather have a single valve inflation system, your dealer can supply the required "T" fitting.

## **IMPORTANT!**

*For your safety and to prevent possible damage to your vehicle, do not exceed the maximum load recommended by the vehicle manufacturer (GVWR). Although your Air Helper Springs are rated at a maximum inflation pressure of 100 psi, this pressure may allow you to carry too great a load on some vehicles. It is best to have your vehicle weighed once it is completely loaded and compare that weight to the maximum allowed. Check your vehicle owner's manual or data plate on driver's side door for maximum loads listed for your vehicle.*

*When inflating your Air Helper Springs, add air pressure in small quantities, checking pressure frequently during inflation. The air spring requires much less air volume than a tire and, therefore, inflates much quicker.*

## **PARTS LIST**

AIR SPRING	6781	2
UPPER BRACKET	5699	2
LEFT FRAME BRACKET	5701	1
RIGHT FRAME BRACKET	5700	1
LEFT LOWER BRACKET	5702	1
RIGHT LOWER BRACKET	5703	1
SPACER	5366	2
NUT PLATES	5660	4
AIR LINE TUBING	0938	1
BAIL CLAMP	3410	4

## **BOLT PACK (A21-760-2525)**

INFLATION VALVE	3032	2
ELBOW FITTING	3031	2
3/8"-16 FLANGE LOCK NUT		20
3/8"-16 X 1" HEX HEAD BOLT		12
3/8"-16 X 3/4" FLANGE BOLT		2
3/8"-16 X 2" FLANGE BOLT		2
5/16" FLAT WASHER		4
THERMAL SLEEVE		2
NYLON TIE		6
CAUTION TAG		2

**FIGURE "A"**  
**2525**

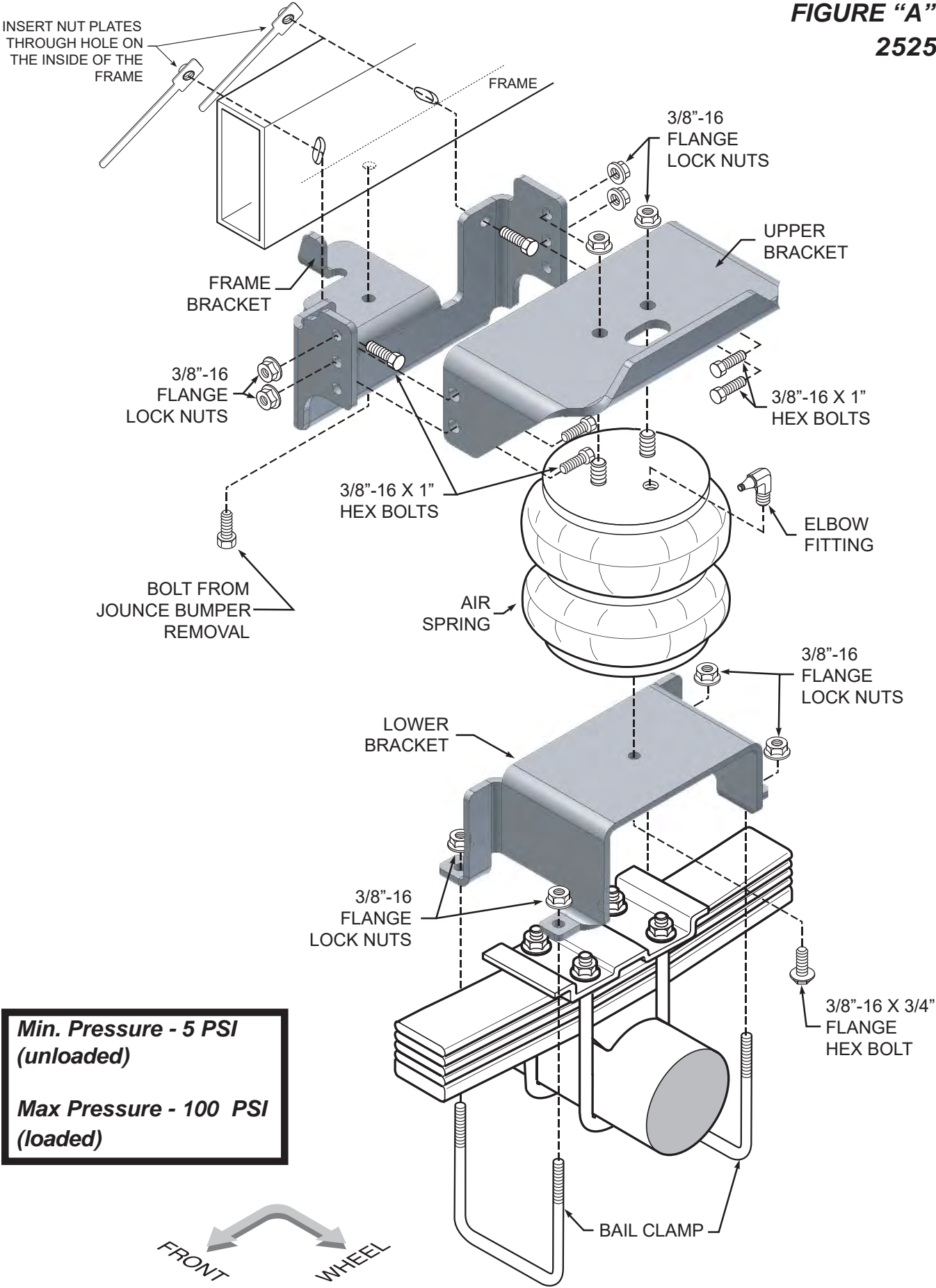

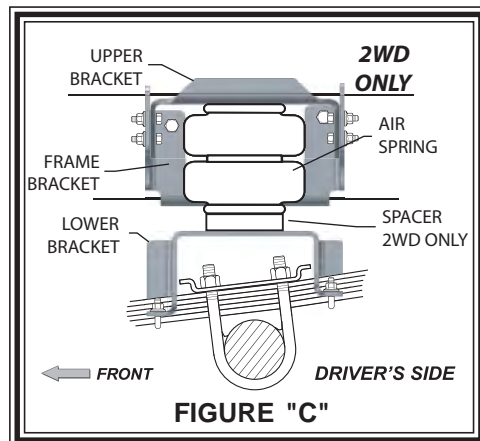
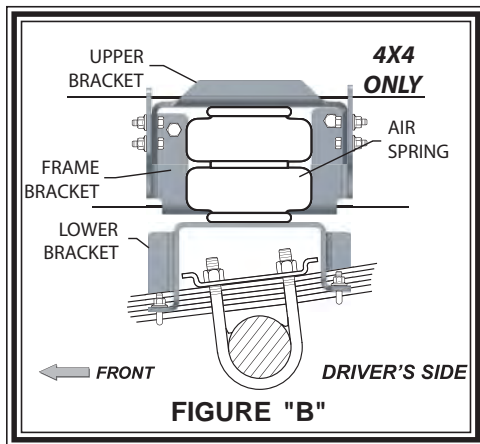

### STEP 1 – PREPARE THE VEHICLE

With the vehicle on a solid, level surface chock the front wheels. Raise the vehicle by the rear axle and set on jack stands rated for your vehicles weight. Remove the rear wheels. Remove the jounce bumpers from the under side of the frame rail. The jounce bumper will not be re-used with the kit but the bolt will be re-used.

### STEP 2 – ATTACH THE UPPER BRACKET

Select one air helper spring and one upper bracket from your kit. Insert the studs of the air spring into the mounting holes of the upper bracket. Make sure the air inlet is visible through the large access hole. Fasten the upper bracket to the air spring using the 3/8"-16 flange nuts, see *Figure "A"*. Install the elbow fitting into the air spring through the large access hole in the upper bracket. Tighten the air fitting securely to engage the orange thread sealant. Position the fitting to point to the anticipated location of the air inflation valves.

### STEP 3A – ATTACH THE LOWER BRACKET (4x4)

Select one lower bracket and fasten it to the air spring with a 3/8"-16 x 3/4" flange bolt (*finger tight*), as shown in *Figure "A"*.

### STEP 3B – ATTACH THE LOWER BRACKET (4x2)

Select one lower bracket and spacer bracket and attach them to the air spring with a 3/8"-16 x 2" flange hex bolt (*finger tight*). See *Figure "B"*.

### STEP 4 – ATTACH THE FRAME BRACKET TO THE FRAME

Attach the frame bracket to the bottom of the frame using the jounce bumper bolt re-installed in the hole from the jounce bumper removal. See *Figure "A"*.

Next, insert the 3/8"-16 x 1" hex head bolts through the frame bracket and into the holes on the outside of the frame. Secure with nut plates inserted through the hole on the inside of the frame. See *Figure "A"*. **DO NOT OVER TIGHTEN! 20 FT/LBS Max.**

### STEP 5 – INSTALLING THE ASSEMBLY TO THE VEHICLE

Place the assembly on the leaf stack over the spring retainer and align the holes in the upper bracket with the holes in the frame bracket. Install four 3/8" x 1" hex head bolts and fasten using 3/8"-16 flange nuts. Secure the lower bracket to the leaf stack using bail clamps and 3/8"-16 flange nuts. See *Figures "A" & "B"*. Be sure to tighten the bolt holding the bottom of the air spring to the lower bracket.

### STEP 5 - INSTALLATION TO THE PASSENGER'S SIDE ASSEMBLY

Reverse any orientations when assembling and installing the right, or passenger, side of the vehicle.

### STEP 6 - INSTALL THE AIR LINE AND THE INFLATION VALVE

Uncoil the air line tubing and cut it into two equal lengths. **DO NOT FOLD OR KINK THE TUBING.** Try to make the cut as square as possible. Insert one end of the tubing into the elbow fitting installed in the top of the air helper spring. Push the tubing into the fitting as far as possible. Select a location on the vehicle for the air inflation valves. The location can be on the bumper or the body of the vehicle, as long as it is in a protected location so the valve will not be damaged, but maintain accessibility for the air chuck, see *Figure "E"*. Drill a 5/16" hole and install the air inflation valve using two 5/16" flat washers per valve as supports, see *Figure "D"*. Run the tubing from the air helper spring to the inflation valve, routing it to avoid direct heat from the engine, exhaust pipe, and away from sharp edges. Thermal sleeves have been provided for these conditions. If a thermal sleeve is required simply slide the sleeve over the air line tubing to the location requiring protection. The air line tubing should not be bent or curved sharply as it may buckle. Secure the tubing in place with the nylon ties provided. Push the end of the air line tubing into the inflation valve as illustrated, see *Figure "D"*.

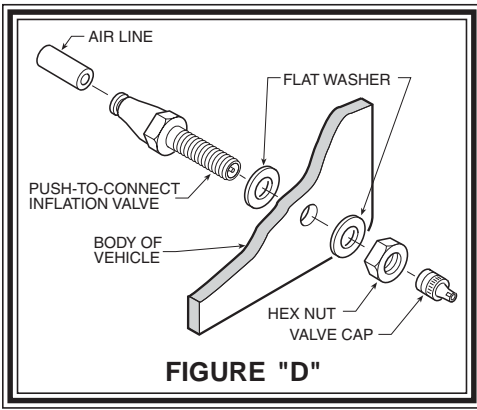

**FIGURE "D"**

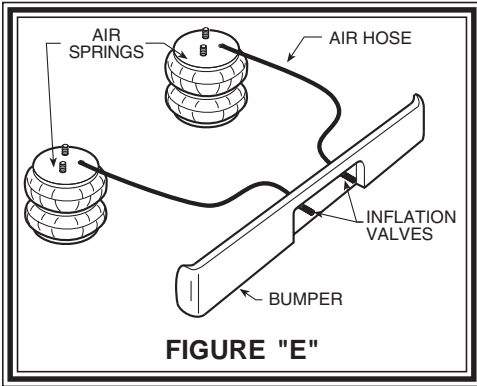

**FIGURE "E"**

**STEP 7 - CHECK THE AIR SYSTEM**

Once the inflation valves are installed inflate the air helper springs to 70 psi and check the fittings for air leaks with an applied solution of soap and water. If a leak is detected at a tubing connection then check to make sure that the tube is cut as square as possible and that it is pushed completely into the fitting. The tubing can easily be removed from the fittings by pushing the collar towards the body of the fitting and then pulling out the tube. If a leak is detected where the fitting screws into the spring, screw the fitting into the air spring until the leak stops. Reinstall the tubing and reinflate the air springs and check for leaks as noted above.

This now completes the installation. Install the wheels and torque the lug nuts to the manufactures specifications. Raise the vehicle by the rear axle and remove the jack stands and lower the vehicle back onto the ground. Re-attach the negative battery cable and remove the wheel chocks from the wheels. Before proceeding, check once again to be sure you have proper clearance around the air springs. With a load on your vehicle and the air helper springs inflated, you must have at least 1/2" clearance around the air springs. As a general rule, the air helper springs will support approximately 40 lbs. of load for each psi of inflation pressure (per pair). For example, 50 psi of inflation pressure will support a load of 2000 lbs. per pair of air helper springs. *FOR BEST RIDE* use only enough air pressure in the air helper springs to level the vehicle when viewed from the side (front to rear). This amount will vary depending on the load, location of load, condition of existing suspension and personal preference.

**NOTE:**

Too much air pressure in the air helper springs will result in a firmer ride, while too little air pressure will allow the air helper spring to bottom out over rough conditions. Too little air pressure will also not provide the improvement in handling that is possible. **TOPREVENTPOSSIBLEDAMAGEMAINAINAMINIMUMOF5psiINTHEAIRHELPERSPRINGSATALLTIMES.**

Once the air helper springs are installed, it is recommended that the vehicle not be lifted by the frame, as over-extension may occur, resulting in damage to the air helper springs. However, should it become necessary to raise the vehicle by the frame, deflate both air helper springs completely.

<b>NOTE:</b>	
<b>MIN PRESSURE</b>	<b>5 PSI</b>
<b>MAX PRESSURE (LOADED)</b>	<b>100 PSI</b>