

WARNING:

Do not inflate this assembly when it is unrestricted. The assembly must be restricted by the suspension or other adequate structure. Do not inflate beyond 100 psi. Improper use or over inflation may cause property damage or severe personal injury.

INSTALLATION INSTRUCTIONS

Congratulations - your new Air Helper Springs are quality products capable of improving the handling and comfort of your vehicle. As with all products, proper installation is the key to obtaining all of the benefits your kit is capable of delivering. Please take a few minutes to read through the instructions to identify the components and learn where and how they are used. It is a good idea to start by comparing the parts in your kit with the parts list below.

The heart of the kit is, of course, the air helper springs. Remember that the air helper springs must flex and expand during operation, so be sure that there is enough clearance to do so without rubbing against any other part of the vehicle.

Be sure to take all applicable safety precautions during the installation of the kit. The instructions listed in this brochure and the illustrations all show the left, or driver's side of the vehicle. To install the right side assembly simply follow the same procedures.

This kit includes inflation valves and air lines for each air spring. This will allow you to compensate for unbalanced loads. If you would rather have a single inflation valve system to provide equal pressure to both air springs, your dealer can supply the optional "T" fitting.

IMPORTANT!

For your safety and to prevent possible damage to your vehicle, do not exceed the maximum load recommended by the vehicle manufacturer (GVWR). Although your Air Helper Springs are rated at a maximum inflation pressure of 100 psi, this pressure may allow you to carry too great a load on some vehicles. It is best to have your vehicle weighed once it is completely loaded and compare that weight to the maximum allowed. Check your vehicle owner's manual or data plate on driver side door for maximum loads listed for your vehicle.

When inflating your Air Helper Springs, add air pressure in small quantities, checking pressure frequently during inflation. The air spring requires much less air volume than a tire and, therefore, inflates much quicker.

PARTS LIST

267C AIR SPRING	6781	2	3/8" WASHER	8
UPPER BRACKET	5187	2	3/8" LARGE WASHER	8
LOWER BRACKET	5092	2	5/16" FLAT WASHER	4
BRACKET STRAP	5086	4	18 ft. TUBING	0938 1
BRACKET STRAP	5093	2	INFLATION VALVE	3032 2
3/8"-16 X 3/4" FLANGED HEX BOLT		2	ELBOW FITTING	3031 2
3/8"-16 X 8" CARRIAGE BOLT		8	THERMAL SLEEVE	0899 2
3/8"-16 X 1-1/2" HEX BOLT		8	NYLON TIE	6
3/8"-16 FLANGE LOCK NUT		20	CAUTION TAG	2

FIGURE "A"

NOTE: Both illustrations are of the left, or drivers side, of the vehicle. Reverse any orientations when assembling and installing the right, or passenger, side of the vehicle.

KIT ASSEMBLY

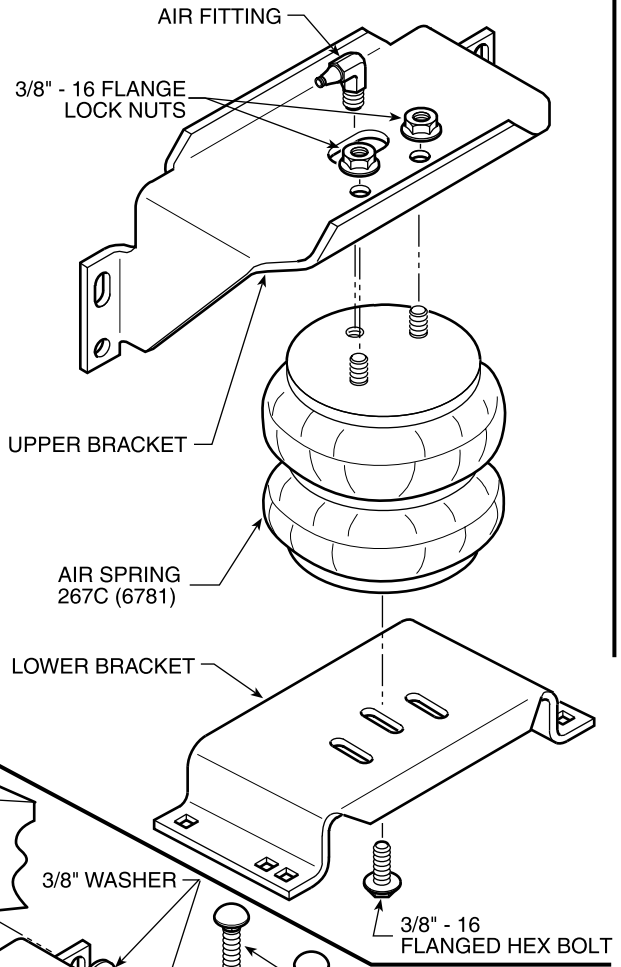

KIT TO FRAME ASSEMBLY

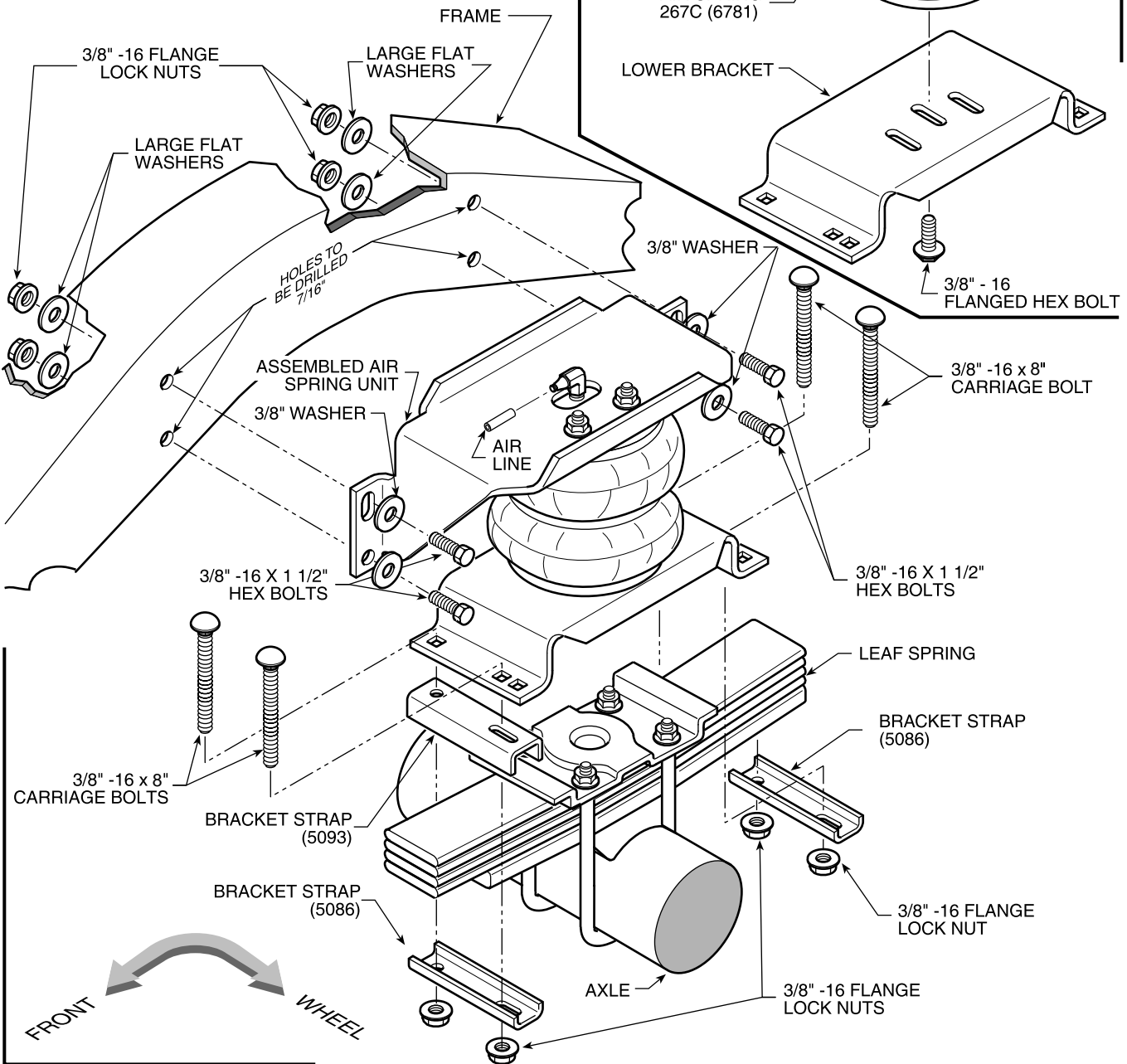

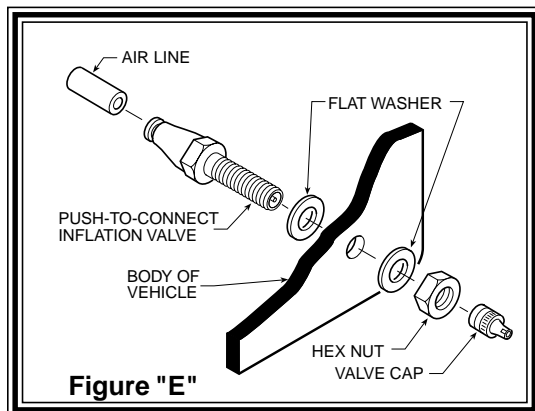
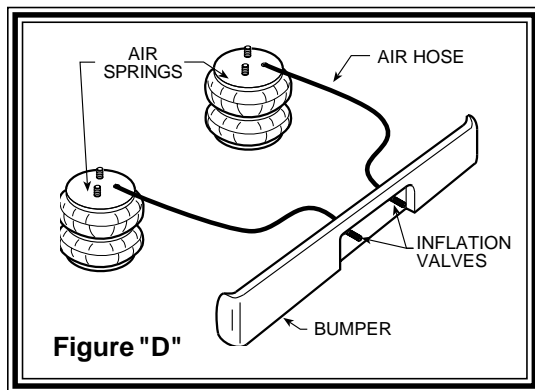
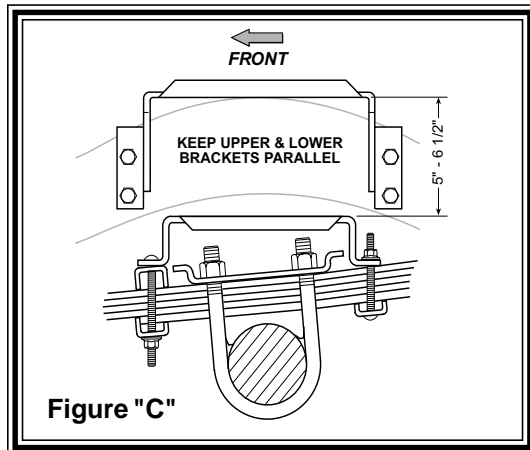
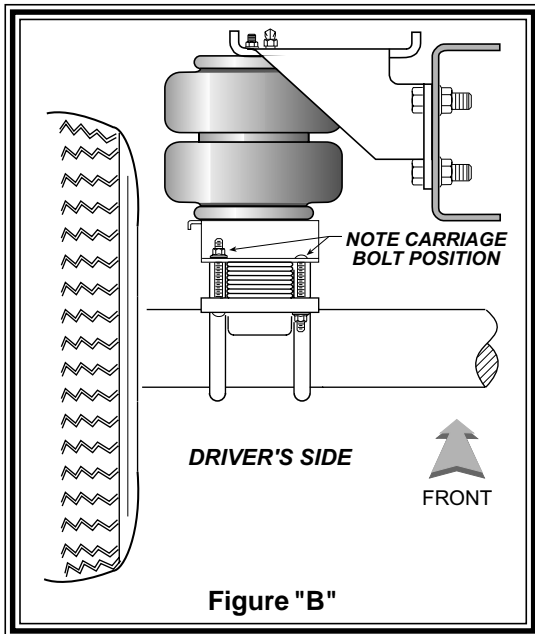

STEP 1 - PREPARE THE VEHICLE

With the vehicle on a solid, level surface chock the front wheels. Raise the vehicle by the rear axle and remove the rear wheels. After the removal of the wheels lower the vehicle so the axle rests on jack stands rated for your vehicles weight. Make sure the negative battery cable is disconnected from the battery.

STEP 2 - PREASSEMBLE THE KIT

Select one air helper spring from your kit and an upper bracket. Align the studs on the air spring with the holes on the upper bracket making sure the air inlet hole can be seen through the slot in the upper bracket, *see Figure "A"*. Use the 3/8"-16 flange lock nuts to secure the upper bracket to the air spring. Install the air fitting as shown in *Figure "A"*. Tighten the air fitting securely to engage the orange thread sealant. Point the elbow fitting in the direction of the inflation valve location. Position the lower bracket as shown in *Figures "A" & "C"* and fasten the lower bracket to the air helper spring using a 3/8"-16 flange bolt (*finger tight*). The lip on the lower bracket will face towards the tire. *See Figures "A" & "B"*.

STEP 3 - PRE-FIT MARK AND DRILL HOLES

Place the assembly on the driver's side on top of the leaf stack straddling the leaf spring retainer and inserting the 1" spacer as shown in *Figures "A" & "C"*. Visually align the air spring so that it is as vertical as possible refer to *Figures "A" & "B"*. Place the upper bracket against the frame rail and use the holes in the bracket as a template to mark the holes to be drilled in the frame rail. The distance between the upper and lower bracket should be 5"-6 1/2" as shown in *Figure "C"*. Mark holes to be drilled with a center punch and remove the air spring assembly. ***Before drilling the holes make sure all electrical, brake and fuel lines are cleared from the path of the drill.*** Damage to lines can be avoided by inserting a piece of wood between the frame rail and any lines in the path of the drill. Drill the four holes in the frame rail using a 7/16" drill bit. *See Figure "A"*.

STEP 4- INSTALLATION TO THE VEHICLE

After drilling the holes in the frame rail place the assembled air spring back on the leaf stack making sure the lower bracket is placed over the retainer (*see Figure "A" & "C"*). Install the 3/8"-16 x 1 1/2" hex bolts and 3/8" washers through the upper bracket holes and the holes that were drilled in the frame rail. Next fasten the upper bracket to the frame rail using the 3/8"-16 flange lock nuts and special flat washers to the back side of the frame rail refer to *Figures "A" & "B"*. The next step is to attach the lower bracket to the leaf spring assembly. Notice that the lower bracket is angled with the arc of the suspension. Use the 1" spacer placed between the lower bracket and the leaf spring towards the front of the vehicle as shown in *Figures "A" & "C"*. Insert the 8" carriage bolts capturing both the 1" spacer and the lower bracket, *see Figure "A"*. The carriage bolts should straddle the leaf stack, refer to *Figures "A" & "B"*. Slide the bracket straps onto the carriage bolts as to clamp the lower

bracket to the leaf stack. *See Figures "A" and "B"*. Fasten using the 3/8"-16 flange lock nuts. Adjust the air spring to achieve vertical alignment. Tighten the 3/8"-16 flange bolt that holds the air spring to the lower bracket using an open end wrench.

STEP 5- INSTALLATION OF THE PASSENGER'S SIDE ASSEMBLY

Follow steps 1-4 for assembly and installation of the passenger's side.

STEP 6- INSTALL THE AIR LINE AND INFLATION VALVE

Uncoil the air tubing and cut it into two equal lengths. *DO NOT FOLD OR KINK THE TUBING*. Try to make the cut as square as possible. Insert one end of the tubing into the elbow fitting installed in the top of the air helper spring. Push the tubing into the fitting as far as possible refer to *Figure "A"*.

Select a location on the vehicle for the air inflation valves. The location can be on the bumper or the body of the vehicle, as long as it is in a protected location so the valve will not be damaged, but maintain accessibility for the air chuck (*see Figure "D"*). Drill a 5/16" hole and install the air inflation valve using two 5/16" flat washers per valve as supports (*see Figure "E"*). Run the tubing from the air helper spring to the inflation valve, routing it to avoid direct heat from the engine, exhaust pipe, and away from sharp edges. Thermal sleeves have been provided for these conditions. If a thermal sleeve is required simply slide the sleeve over the air line tubing to the location requiring protection. The air line tubing should not be bent or curved sharply as it may buckle. Secure the tubing in place with the nylon ties provided. Push the end of the air line tubing into the inflation valve as illustrated (*see Figure "E"*).

STEP 7 - CHECK THE AIR SYSTEM

Once the inflation valves are installed inflate the air helper springs to 70 *psi*. and check the fittings for air leaks with an applied solution of soap and water. If a leak is detected at a tubing connection then check to make sure that the tube is cut as square as possible and that it is pushed completely into the fitting. The tubing can easily be removed from the fittings by pushing the collar towards the body of the fitting and then pulling out the tube. If a leak is detected where the brass elbow fitting screws into the spring, remove the tubing (see trouble shooting section of the operating instruction manual for removal procedure), then screw the elbow into the spring one additional turn or until the leak stops. Reinstall the tubing and reinflate the air springs and check for leaks as noted above.

This now completes the installation. Install the wheels and torque the lug nuts to the manufactures specifications. Raise the vehicle by the rear axle and remove the jack stands and lower the vehicle back onto the ground. Re-attach the negative battery cable and remove the wheel chocks from the front wheels. Before proceeding, check once again to be sure you have proper clearance around the air springs. With a load on your vehicle and the air helper springs inflated, you must have at least 1/2" clearance around the air springs. As a general rule, the air helper springs will support approximately 40 lbs. of load for each *psi*. of inflation pressure (per pair). For example, 50 *psi*. of inflation pressure will support a load of 2000 lbs. per pair of air helper springs. *FOR BEST RIDE* use only enough air pressure in the air helper springs to level the vehicle when viewed from the side (front to rear). This amount will vary depending on the load, location of load, condition of existing suspension and personal preference.

NOTE:

Too much air pressure in the air helper springs will result in a firmer ride, while too little air pressure will allow the air helper spring to bottom out over rough conditions. Too little air pressure will also not provide the improvement in handling that is possible. ***TO PREVENT POSSIBLE DAMAGE MAINTAIN A MINIMUM OF 20 *psi*. IN THE AIR HELPER SPRINGS AT ALL TIMES.***

MIN PRESSURE	20 PSI
MAX PRESSURE (LOADED)	100 PSI