

## WARNING:

Do not inflate this assembly when it is unrestricted. The assembly must be restricted by the suspension or other adequate structure. Do not inflate beyond 100 psi. Improper use or over inflation may cause property damage or severe personal injury.

## INSTALLATION INSTRUCTIONS

Congratulations - your new Air Helper Springs are quality products capable of improving the handling and comfort of your vehicle. As with all products, proper installation is the key to obtaining all of the benefits your kit is capable of delivering. Please take a few minutes to read through the instructions to identify the components and learn where and how they are used. It is a good idea to start by comparing the parts in your kit with the parts list below.

The heart of the kit is, of course, the air helper springs. Remember that the air helper springs must flex and expand during operation, so be sure that there is enough clearance to do so without rubbing against any other part of the vehicle.

Be sure to take all applicable safety precautions during the installation of the kit. The instructions listed in this brochure and the illustrations all show the left, or driver's side of the vehicle. To install the right side assembly simply follow the same procedures.

This kit includes inflation valves and air lines for each air spring. This will allow you to compensate for unbalanced loads. If you would rather have a single inflation valve system to provide equal pressure to both air springs, your dealer can supply the optional "T" fitting.

## IMPORTANT!

*For your safety and to prevent possible damage to your vehicle, do not exceed the maximum load recommended by the vehicle manufacturer (GVWR). Although your Air Helper Springs are rated at a maximum inflation pressure of 100 psi, this pressure may allow you to carry too great a load on some vehicles. It is best to have your vehicle weighed once it is completely loaded and compare that weight to the maximum allowed. Check your vehicle owner's manual or data plate on driver side door for maximum loads listed for your vehicle.*

*When inflating your Air Helper Springs, add air pressure in small quantities, checking pressure frequently during inflation. The air spring requires much less air volume than a tire and, therefore, inflates much quicker.*

## PARTS LIST

AIR SPRING	6868	2	3/8"-16 LOCKNUT	6
UPPER LEFT BRACKET	5506	1	5/16" X 5 1/2" X 2 1/4" BAIL CLAMP	4
UPPER RIGHT BRACKET	5507	1	5/16"-18 LOCKNUT	8
LOWER LEFT BRACKET	5508	1	3/8"-16 NUT PLATE	2
LOWER RIGHT BRACKET	5509	1	5/8"-18 JAM NUT	2
LEFT U-BOLT CLAMP	5510	1	5/16" FLAT WASHER	4
RIGHT U-BOLT CLAMP	5511	1	18 ft. TUBING	0938
BRACKET CLAMP	5181	2	INFLATION VALVE	3032
HEAT SHIELD		1	STRAIGHT FITTING	3055
EXHAUST CLAMP		2	THERMAL SLEEVE	0899
3/8"-16 X 5 1/2" CARRIAGE BOLT		6	NYLONTIE	8
3/8"-16 X 1" HEX BOLT		2	CAUTION TAG	2
3/8"-16 X 5/8" FLAT HEAD BOLT		2		

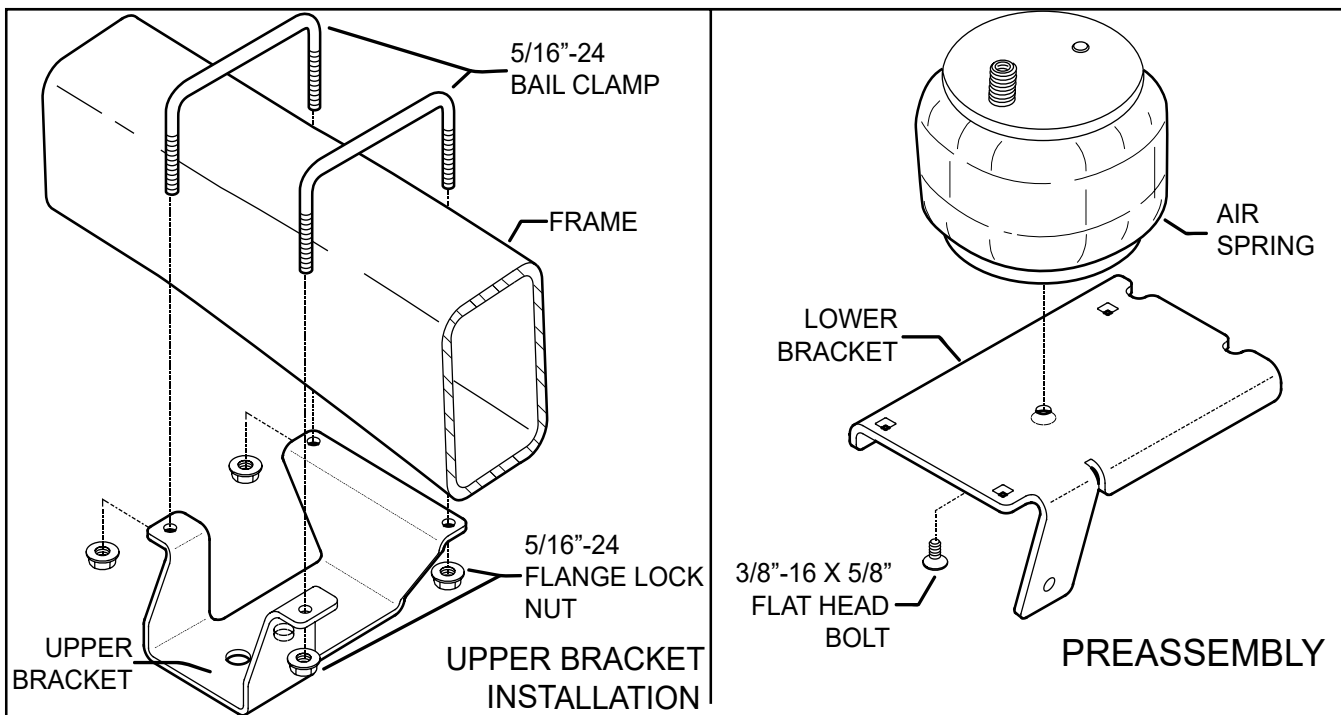

Illustration is of the right, or passenger side of the vehicle. Repeat instructions for the left, or driver's side.

**IMPORTANT!:**  
SEE FLYER FOR  
HEAT SHIELD INSTALLATION

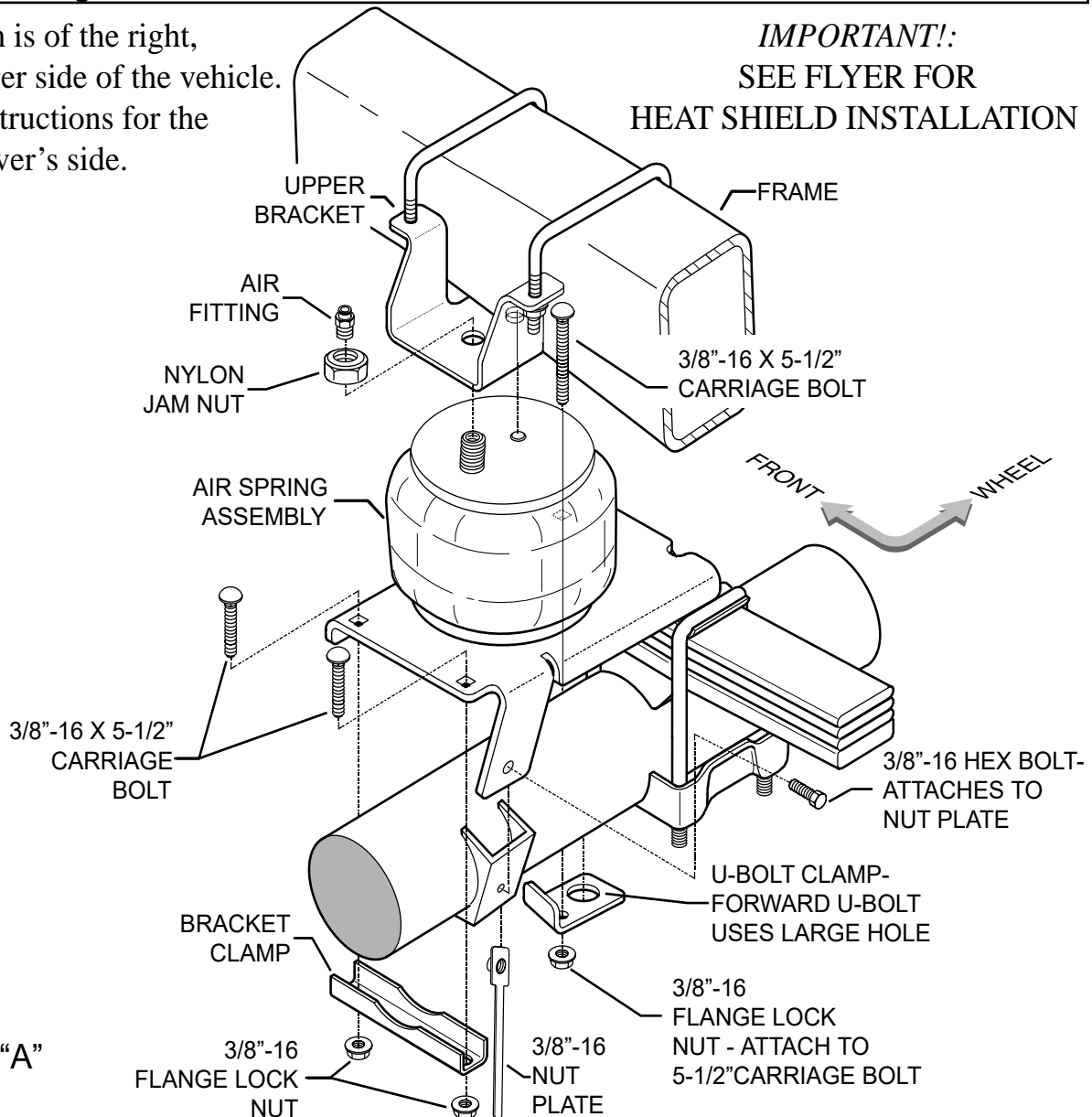
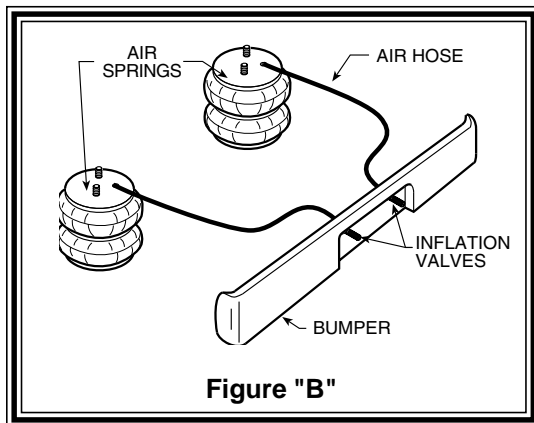

FIGURE "A"  
2423



**Figure "B"**

## **STEP 1 - PREPARE THE VEHICLE**

With the vehicle on a solid, level surface chock the front wheels. Raise the vehicle by the rear axle and remove the rear wheels. After the removal of the wheels lower the vehicle so the axle rests on jack stands rated for your vehicles weight. Make sure the negative battery cable is disconnected from the battery.

## **STEP 2 - PREASSEMBLE**

Select one air helper spring from your kit and the lower right bracket. Use the 3/8"-16 flat head bolt to secure the bracket to the air spring. *See Figure "A"*.

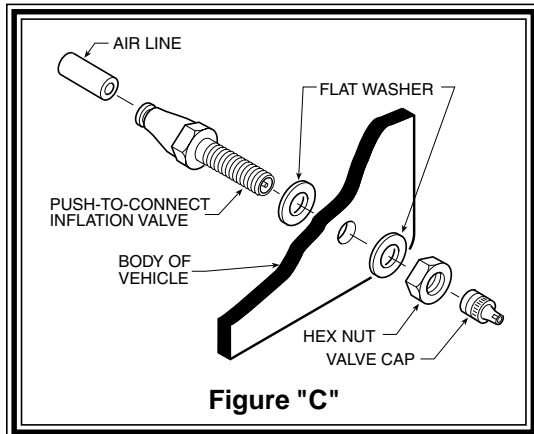

**Figure "C"**

Next, select the upper right bracket, two bail clamps, and four 5/16" lock nuts. Place the upper bracket on the frame centered over the axle as shown in *Figure "A"*. Install the bail clamps over the frame and through the holes in the upper bracket and loosely fasten the 5/16" lock nuts. *See Figure "A"*.

## **STEP 3- INSTALLATION TO THE VEHICLE**

Place the air spring assembly on the axle and under the upper bracket. Insert the large stud into the larger hole and the alignment pin into the smaller hole. Install the Nylon jam nut onto the air spring stud then install the air fitting. Tighten the air fitting securely to engage the orange thread sealant. *See Figure "A"*.

Next, make sure the lower bracket is level on the axle and, using the bracket as a template, drill a 7/16" hole in the shock mount on the axle as shown in *Figure "A"*. Position the nut plate inside the shock mount and install the 1" hex bolt affixing the lower bracket to the axle.

Place one of the 5 1/2" carriage bolts into the square hole closest to the leaf spring stack. Select the right-side U-bolt clamp and place it on the vehicle so the large hole is around the forward-most axle U-bolt and the carriage bolt inserts into the small hole. Install and tighten one 3/8" lock nut. *See Figure "A"*.

Next place two of the 5 1/2" carriage bolts into the remaining square holes on the lower brackets. Place the bracket clamp onto the carriage bolts from under the axle then install and tighten two 3/8" lock nuts as shown in *Figure "A"*.

Tighten the 5/16" lock nuts on the bail clamp and make sure all brackets are secure.

**NOTE: On the right, or passenger's side of the vehicle, a heat shield is required. Please see the heat shield flyer for proper installation.**

## **STEP 4- INSTALLATION OF THE DRIVER'S SIDE ASSEMBLY**

Follow steps 1-4 for assembly and installation of the driver's side assembly.

**NOTE: On the left, or driver's side of the vehicle, use some of the provided nylon ties to secure the factory installed wire loom out of the way to assist in installation.**

## **STEP 5- INSTALL THE AIR LINE AND INFLATION VALVE**

Uncoil the air tubing and cut it into two equal lengths. **DO NOT FOLD OR KINK THE TUBING.** Try to make the cut as square as possible. Insert one end of the tubing into the air fitting installed in the top of the air helper spring. Push the tubing into the fitting as far as possible refer to *Figure "A"*.

Select a location on the vehicle for the air inflation valves. The location can be on the bumper or the body of the vehicle, as long as it is in a protected location so the valve will not be damaged, but maintain accessibility for the air chuck (*see Figure "B"*). Drill a 5/16" hole and install the air inflation valve using two 5/16" flat washers per valve as supports (*see Figure "C"*). Run the tubing from the air helper spring to the inflation valve, routing it to avoid direct heat from the engine, exhaust pipe, and away from sharp edges. Thermal sleeves have been provided for these conditions. If a thermal sleeve is required simply slide the sleeve over the air line tubing to the location requiring protection. The air line tubing should not be bent or curved sharply as it may buckle.

Secure the tubing in place with the nylon ties provided. Push the end of the air line tubing into the inflation valve as illustrated, *see Figure "C"*.

## **STEP 6 - CHECK THE AIR SYSTEM**

Once the inflation valves are installed inflate the air helper springs to 70 *psi.* and check the fittings for air leaks with an applied solution of soap and water. If a leak is detected at a tubing connection then check to make sure that the tube is cut as square as possible and that it is pushed completely into the fitting. The tubing can easily be removed from the fittings by pushing the collar towards the body of the fitting and then pulling out the tube. If a leak is detected where the brass elbow fitting screws into the spring, remove the tubing (see trouble shooting section of the operating instruction manual for removal procedure), then screw the elbow into the spring one additional turn or until the leak stops. Reinstall the tubing and reinflate the air springs and check for leaks as noted above.

This now completes the installation. Install the wheels and torque the lug nuts to the manufactures specifications. Raise the vehicle by the rear axle and remove the jack stands and lower the vehicle back onto the ground. Re-attach the negative battery cable and remove the wheel chocks from the front wheels. Before proceeding, check once again to be sure you have proper clearance around the air springs. With a load on your vehicle and the air helper springs inflated, you must have at least 1/2" clearance around the air springs. As a general rule, the air helper springs will support approximately 40 lbs. of load for each *psi.* of inflation pressure (per pair). For example, 50 *psi.* of inflation pressure will support a load of 2000 lbs. per pair of air helper springs. *FOR BEST RIDE* use only enough air pressure in the air helper springs to level the vehicle when viewed from the side (front to rear). This amount will vary depending on the load, location of load, condition of existing suspension and personal preference.

### **NOTE:**

Too much air pressure in the air helper springs will result in a firmer ride, while too little air pressure will allow the air helper spring to bottom out over rough conditions. Too little air pressure will also not provide the improvement in handling that is possible. ***TO PREVENT POSSIBLE DAMAGE MAINTAIN A MINIMUM OF 5 *psi.* IN THE AIR HELPER SPRINGS AT ALL TIMES.***

### **NOTE:**

Once the air helper springs are installed, it is recommended that the vehicle not be lifted by the frame, as over-extension may occur, resulting in damage to the air helper springs. However, should it become necessary to raise the vehicle by the frame, deflate both air helper springs completely.

<b>NOTE:</b>	
<b>MIN PRESSURE</b>	<b>5 PSI</b>
<b>MAX PRESSURE (LOADED)</b>	<b>100 PSI</b>