

**WARNING:**

Do not inflate this assembly when it is unrestricted. The assembly must be restricted by the suspension or other adequate structure. Do not inflate beyond 100 P.S.I. Improper use or over inflation may cause property damage or severe personal injury.

**INSTALLATION INSTRUCTIONS**

Congratulations - your new air helper springs are quality products capable of improving the handling and comfort of your vehicle. As with all products, proper installation is the key to obtaining all of the benefits your kit is capable of delivering. Please take a few minutes to read through the instructions to identify the components and learn where and how they are used. It is a good idea to start by comparing the parts in your kit with the parts list below.

The heart of the kit is, of course, the air helper springs. Remember that the air helper springs must flex and expand during operation, so be sure that there is enough clearance to do so without rubbing against any other part of the vehicle.

Be sure to take all applicable safety precautions during the installation of the kit. The instructions listed in this brochure and the illustrations all show the left, or driver's side of the vehicle. To install the right side assembly simply follow the same procedures.

Your kit includes separate inflation valves and air lines for each air helper spring. This will allow you to level your vehicle from side to side as well as from front to back. If you would rather have a single valve inflation system, your dealer can supply the required T-fitting.

**IMPORTANT!**

*For your safety and to prevent possible damage to your vehicle, do not exceed the maximum load recommended by the vehicle manufacturer (GVWR). Although your Air Helper Springs are rated at a maximum inflation pressure of 100 psi, this pressure may allow you to carry too great a load on some vehicles. It is best to have your vehicle weighed once it is completely loaded and compare that weight to the maximum allowed. Check your vehicle owner's manual or data plate on driver side door for maximum loads listed for your vehicle.*

*When inflating your Air Helper Springs, add air pressure in small quantities, checking pressure frequently during inflation. The air spring requires much less air volume than a tire and, therefore, inflates much quicker.*

**PARTS LIST**

AIR SPRING	7325	2	3/8" -16 x 1-1/2" HEX BOLT	8
UPPER BRACKET	5495	2	3/8" LARGE FLAT WASHER	14
LOWER BRACKET	5496	2	5/16" FLAT WASHER	4
BRACKET STRAP/SHIM	5086	8	AIR LINE TUBING	0938 1
BRACKET STRAP/SHIM	5093	2	INFLATION VALVE	3032 2
3/8" -16 FLANGED HEX NUT		20	ELBOW FITTING	3031 2
3/8" -16 x 3/4" FLANGED HEX BOLT		4	THERMAL SLEEVE	2
3/8" -16 x 3" CARRIAGE BOLT		8	NYLON TIE	6
3/8" -16 x 7" CARRIAGE BOLT		8	CAUTION TAG	2

**KIT ASSEMBLY**

**FIGURE "A"**

**NOTE:** Both illustrations are of the left, or driver's side, of the vehicle. Reverse any orientations when assembling and installing the right, or passenger's side of the vehicle.

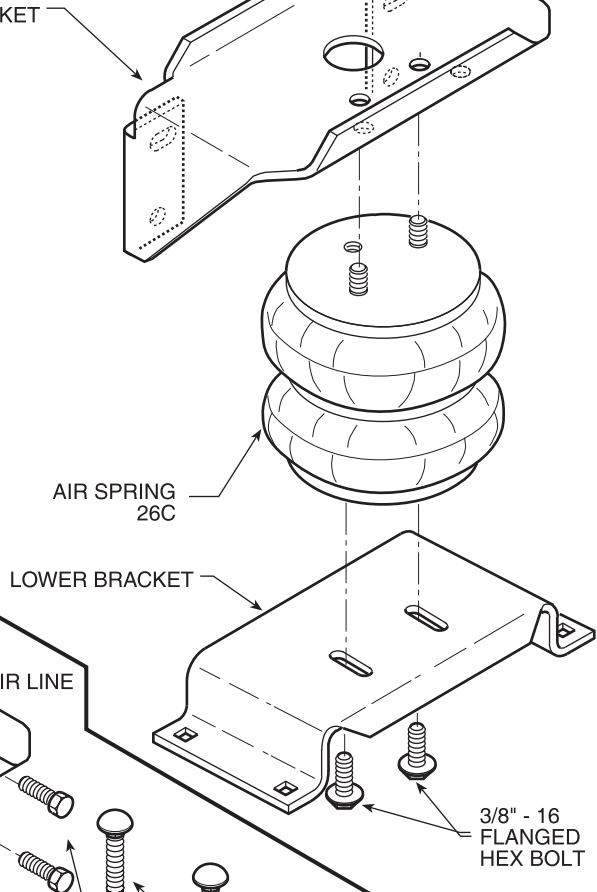
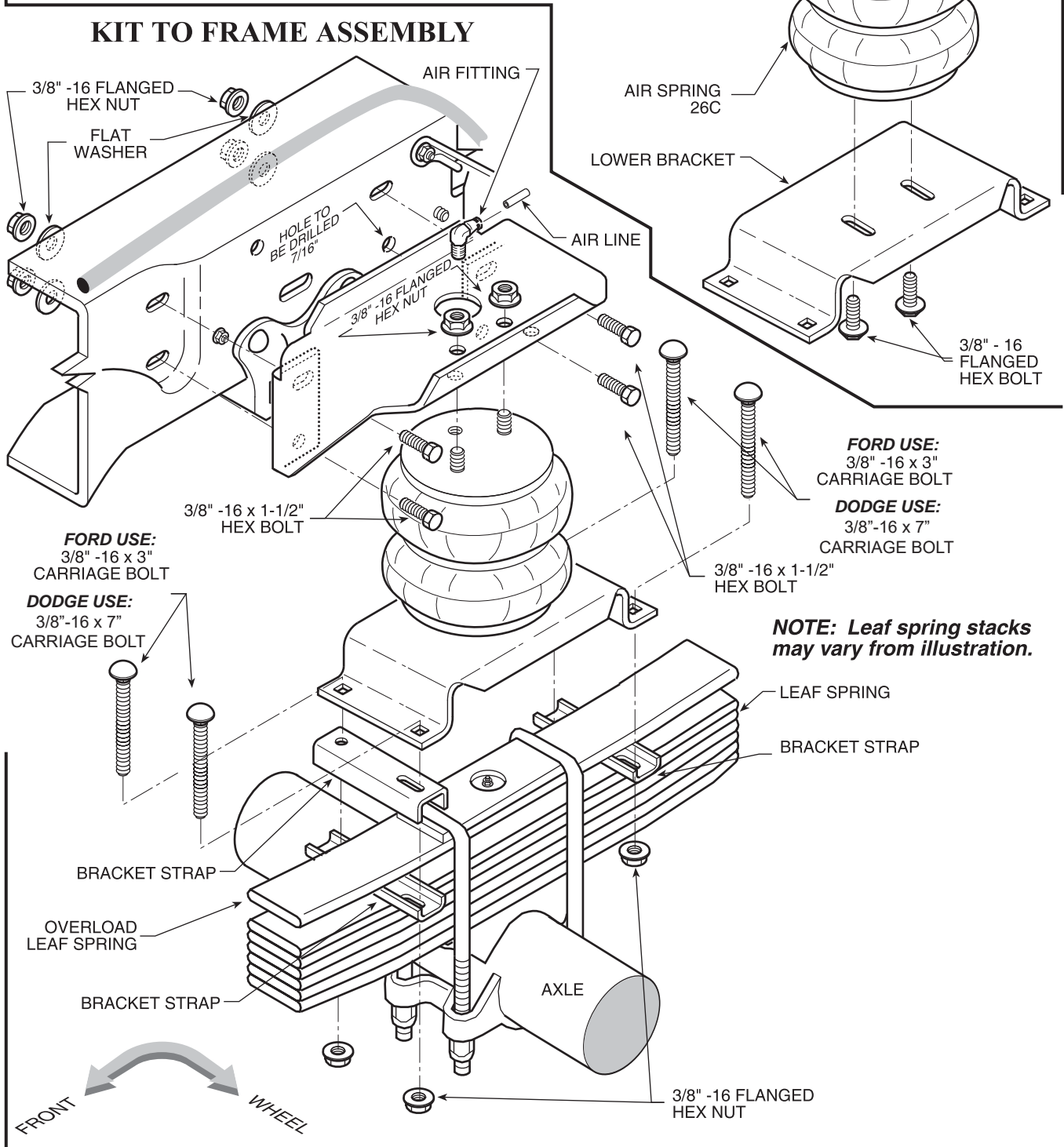

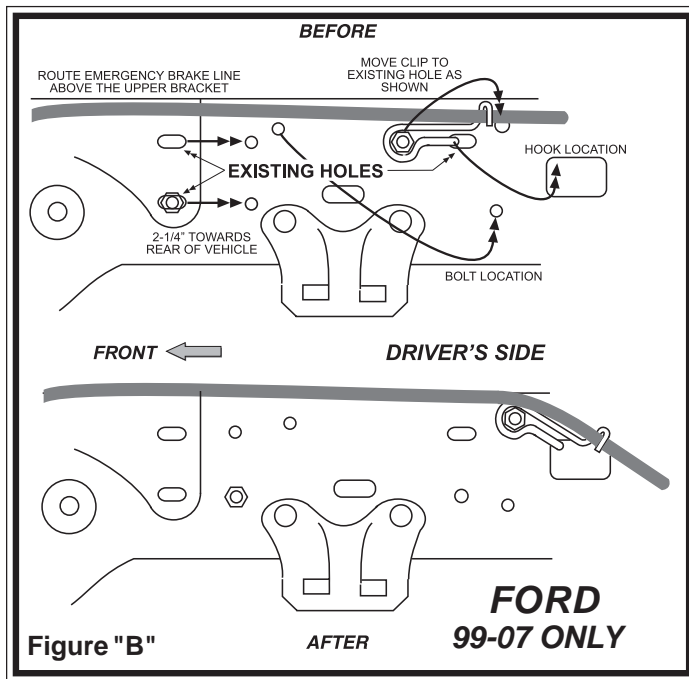

Figure "B"

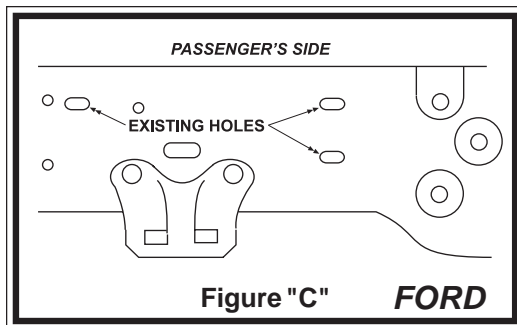

Figure "C" FORD

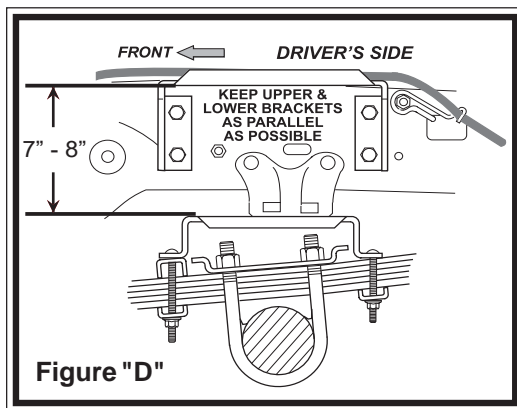

Figure "D"

## STEP 1 - PREPARE THE VEHICLE

With the vehicle is on a solid level surface, chock the front wheels. This vehicle does not have to be raised up to install the kit. Remove the negative battery cable. *This installation assumes that there is no load on the vehicle.*

## STEP 2 - PREASSEMBLE THE KIT

Select one air helper spring and a lower bracket from your kit. Fasten the lower bracket to the air helper spring using a 3/8" -16 x 3/4" flanged hex bolts through the slots in the lower bracket (*finger tight*) see *Figure "A"*.

## STEP 3 - PREPARE THE FRAME (FORD)

The frame rail on the driver's side of the vehicle will require the relocation of three items that will interfere with the upper bracket and air spring. This is accomplished by relocating the existing nuts, bolts, and clips on the frame rail that fall between the upper bracket flanges.

1.) The emergency brake line clip will be moved toward the rear of the vehicle see *Figure "B"*.

2.) The plastic line harness located on the inside of the frame rail will be moved 2-1/4" toward the rear of the vehicle. Two 3/8" holes will have to be drilled to relocate the line harness see *Figure "B"*.

3.) The ground strap bolt must be relocated to fall outside the upper bracket flanges see *Figure "B"*. Please note that the nuts, bolts and clips may be placed in various locations depending upon your specific model.

## STEP 4 - ATTACH THE ASSEMBLY TO THE FRAME

The three existing slots in the Ford frame rail will be used in addition to one hole drilled in the frame rail to attach the upper bracket to the frame rail. The slots will have to be enlarged to allow the bolts to pass through. Place the upper bracket on the outside of the frame rail, aligning the holes in the bracket with the slots in the frame see *Figure "A"*. Using the upper bracket as a template, mark the hole to be drilled in the frame rail with a center punch. Remove the upper bracket and drill a hole on the center mark using a 3/8" drill bit. ***Before drilling, make sure that all electrical, brake, and fuel lines are cleared from the path of the drill bit.*** Damaging the lines can be avoided by inserting a piece of wood between the frame rail and any lines in the path of the drill bit.

Attach the upper bracket to the frame rail using the drilled hole and a 3/8" -16 x 1-1/2" hex bolt, 3/8" -16 flanged hex nut, and large washer, making sure that the remaining holes in the bracket are aligned with the slots in the frame rail see *Figure "A"*. With the upper bracket secured in place, drill through the three holes in the upper bracket and through the slots in the frame rail with a 3/8" drill bit. Using the supplied 3/8" -16 x 3/4" hex bolts, 3/8" -16

flanged hex nuts, and large washers, attach the bracket to the frame rail. Note that three large washers will be placed between the forward bracket flange and the frame rail on both flange attaching locations ***on the left side of the vehicle only***. This allows the air spring assembly to mount flush with the frame rail see *Figure "A"*. Next, install the elbow fitting into the air spring. Tighten the air fitting securely to engage the orange thread sealant. Position the fitting to point to the anticipated location of the air inflation valves, see *Figure "A"* & *"F"*.

## STEP 5 - ATTACH THE LOWER BRACKET TO THE VEHICLE

Place the lower bracket and air spring on the leaf stack. Insert the studs on the upper plate of the air spring through the holes in the upper bracket. Attach the air spring to the upper bracket using two 3/8" -16 flanged hex nuts. Install the 1" spacer between the lower bracket and the leaf stack on the forward end of the assembly to align the upper and lower brackets as close to parallel as possible see *Figures "A"* & *"D"*. Insert the carriage bolts through the square holes in the lower bracket. Slide the bracket straps onto the carriage bolts as to clamp the lower bracket to the leaf stack see *Figures "A"* & *"D"*. Fasten the bracket strap to the carriage bolts using two 3/8" -16 flanged hex nuts. *Note: F-450's & F-550's will clamp around the overload springs only, see Figures "D" & "E"*. Slide the lower bracket forward or backward to align the air spring as close to vertical as possible. Tighten the 3/8" -16 flanged

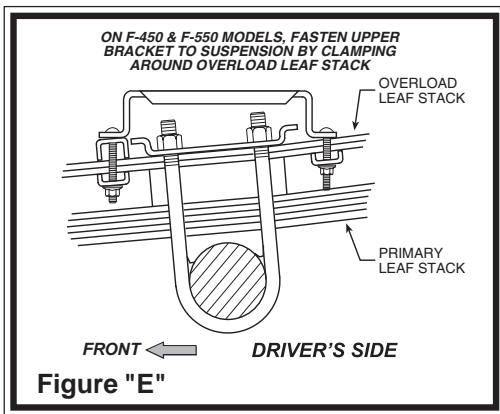

hex bolt that holds the air spring to the lower bracket.

**STEP 6 -INSTALL THE PASSENGER'S SIDE ASSEMBLY**

Reverse any orientations when assembling and installing the right, or passenger's, side of the vehicle. Note that the installation on the passenger's side does not require the flat washers between the upper bracket and the frame rail *see Figure "C"*. The passenger's side installation will not require the relocation of any existing hardware on the frame rail.

**STEP 7 -INSTALL THE AIR LINE AND THE INFLATION VALVE**

Uncoil the air line tubing and cut it into two equal lengths. *DO NOT FOLD OR KINK THE TUBING*. Try to make the cut as square as possible. Insert one end of the tubing into the straight fitting installed in the top of the air helper spring. Push the tubing into the fitting as far as possible *see Figure "A"*.

Select a location on the vehicle for the air inflation valves. The location can be on the bumper or the body of the vehicle, as long as it is in a protected location so the valve will not be damaged, but maintain accessibility for the air chuck *see Figure "F"*. Drill a 5/16" hole and install the air inflation valve using two 5/16" flat washers per valve as supports *see Figure "G"*. Run the tubing from the air helper spring to the inflation valve, routing it to avoid direct heat from the exhaust pipe and away from sharp edges. Thermal sleeves have been provided for these conditions. If a thermal sleeve is required, simply slide the sleeve over the air line tubing to the location requiring protection. The air line tubing should not be bent or curved sharply as it may buckle. Secure the tubing to the vehicle using the provided nylon ties. Push the end of the air line tubing into the inflation valve as far as possible *see Figure "G"*.

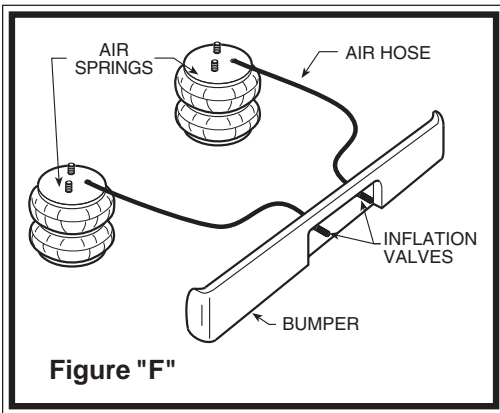

**STEP 8 -CHECK THE AIR SYSTEM**

Once the inflation valves are installed, inflate the air helper springs to 70 psi and check the fittings for air leaks. Using a spray bottle, apply a solution of soap and water to the fittings. If a leak is detected at a airline tubing connection then check to make sure that the airline tube is cut as square as possible and that it is pushed completely into the fitting. The airline tubing can easily be removed from the fittings by exhausting all the pressure in the air springs and then pushing the collar towards the body of the fitting and then, with a pull, remove the airline tubing. Reinstall the tubing and reinflate the air springs and check for leaks as noted above. If a leak is detected where the air fitting screws into the spring, remove the tubing then screw the elbow into the spring 1/4 additional turn. Reinstall the tubing and reinflate the air springs and check for leaks.

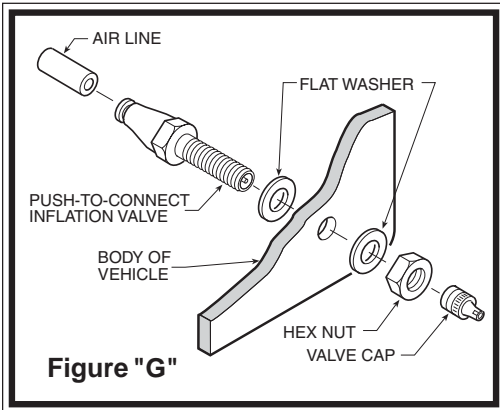

This now completes the installation. Install the wheels and torque the lug nuts to the manufacturer's specification. Raise the vehicle by the axle and remove the jack stands. Lower the vehicle to the ground. Reattach the negative battery cable and remove the wheel chocks from the front wheels. Before proceeding, check once again to be sure you have proper clearance around the air springs. With a load on your vehicle and the air helper springs inflated, you must have at least 1/2" clearance around the air springs. As a general rule, the air helper springs will support approximately 50 lbs. of load for each psi of inflation pressure (per pair). For example, 50 psi of inflation pressure will support a load of 2500 lbs. per pair of air helper springs. *FOR BEST RIDE* use only enough air pressure in the air helper springs to level the vehicle when viewed from the side (front to rear). This amount will vary depending on the load, location of load, condition of existing suspension and personal preference.

**NOTE:**

Too much air pressure in the air helper springs will result in a firmer ride, while too little air pressure will allow the air helper spring to bottom out over rough conditions. Too little air pressure will also not provide the improvement in handling that is possible. **TO PREVENT POSSIBLE DAMAGE MAINTAIN A MINIMUM OF 5 P.S.I. IN THE AIR HELPER SPRINGS AT ALL TIMES.**

<b>NOTE:</b>			
<b>MIN PRESSURE</b>	<b>5 PSI</b>	<b>MAX PRESSURE (LOADED)</b>	<b>100 PSI</b>