

4X4 ONLY

Firestone

DO NOT INSTALL if the truck has been lifted and the stock jounce bumper spacers are not on the vehicle.

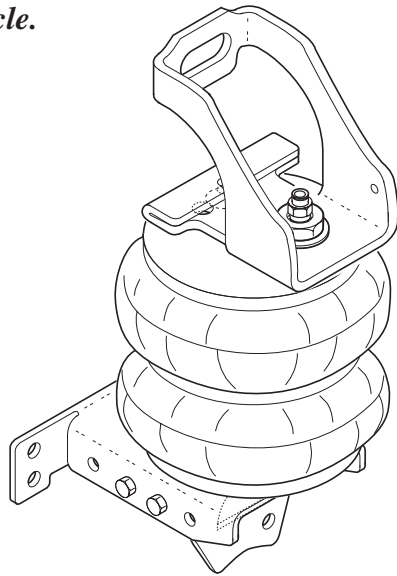

INSTALLATION INSTRUCTIONS

Congratulations - your new Air Helper Springs are quality products capable of improving the handling and comfort of your vehicle. As with all products, proper installation is the key to obtaining all of the benefits your kit is capable of delivering. **Please take a few minutes to read through the instructions to identify the components and learn where and how they are used.** It is a good idea to start by comparing the parts in your kit with the parts list below.

The heart of the air helper spring kit is, of course, the air springs. Remember that the air helper springs must flex and expand during operation, so be sure that there is enough clearance to do so without rubbing against any other part of the vehicle.

Be sure to take all applicable safety precautions during the installation of the kit. The instructions listed in this brochure and the illustrations all show the left, or driver's side of the vehicle. To install the right side assembly simply follow the same procedures.

PARTS LIST

224C AIR SPRING	6401	2	3/8"-16 X 1" HEX HEAD BOLT	12
UPPER BRACKET	5462	2	3/8"-16 X 2 1/2" FLAT HEAD BOLT	2
LOWER BRACKET	5463	2	3/8"-16 FLANGE LOCK NUT	18
LEFT JOUNCE STOP BRACKET	5577	1	3/8" LARGE FLAT WASHER	2
RIGHT JOUNCE STOP BRACKET	5578	1	3/4"-16 X 3" HEX BOLT	2
LONG 4X4 SPACER	5557	2	3/4"-16 HEX HEAD NUT	2
SHORT 4X4 SPACER	5558	2	3/4" INTERNAL TOOTH LOCK WASHER	2
1/2" SPACER	5477	2	3/4" LOCK WASHER	2
FUEL LINE BRACKET	5428	1	3/4" LARGE FLAT WASHER	8
BAIL CLAMP	3077	2	HEAT SHIELD	1004 1
AIR LINE TUBING		1	INFLATION VALVE	3032 2
5/16" - 24 X 3/4" HEX HEAD BOLT		1	STRAIGHT FITTING	3046 2
5/16" - 24 FLANGE NUT		1	THERMAL SLEEVE	2
5/16" FLAT WASHER		4	NYLON TIE	6
3/8"-16 X 3/4" HEX HEAD BOLT		2	CAUTION TAG	2

WARNING:

Do not inflate this assembly when it is unrestricted. The assembly must be restricted by the suspension or other adequate structure. Do not inflate beyond 100 psi. Improper use or over inflation may cause property damage or severe personal injury.

The air springs in this kit have a minimum pressure of 5 psi and maximum of 100 psi after the truck is loaded.

Your kit includes separate inflation valves and air lines for each air helper spring. This will allow you to level your vehicle from side to side as well as from front to back. If you would rather have a single valve inflation system, your dealer can supply the optional "T" fitting.

IMPORTANT!

For your safety and to prevent possible damage to your vehicle, do not exceed the maximum load recommended by the vehicle manufacturer (GVWR). Although your Air Helper Springs are rated at a maximum inflation pressure of 100 psi, this pressure may allow you to carry too great a load on some vehicles. It is best to have your vehicle weighed once it is completely loaded and compare that weight to the maximum allowed. Check your vehicle owner's manual or data plate on driver's side door for maximum loads listed for your vehicle.

When inflating your Air Helper Springs, add air pressure in small quantities, checking pressure frequently during inflation. The air spring requires much less air volume than a tire and, therefore, inflates much quicker.

It is not necessary to jack up the truck to install this Ride-Rite kit, if you DO, please use chocks in front of the front tires. Also, use jack stands beneath the truck's rear axle that are properly rated to support the trucks weight.

UPPER BRACKET ATTACHMENT

FIGURE "A"

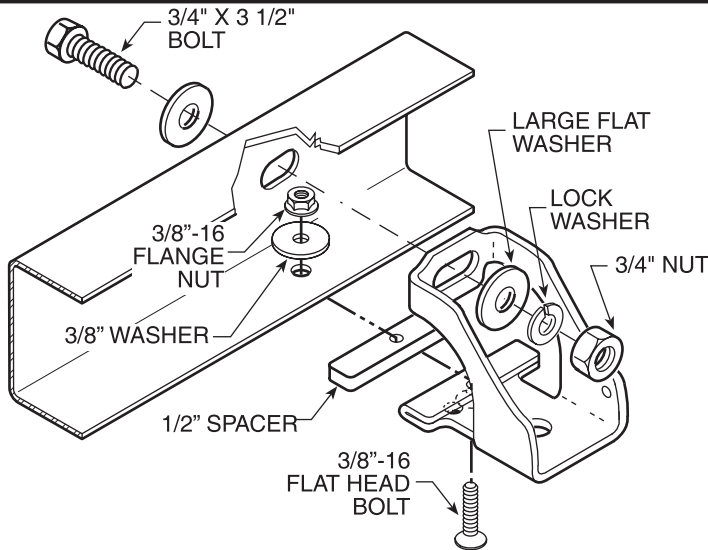

PREASSEMBLY

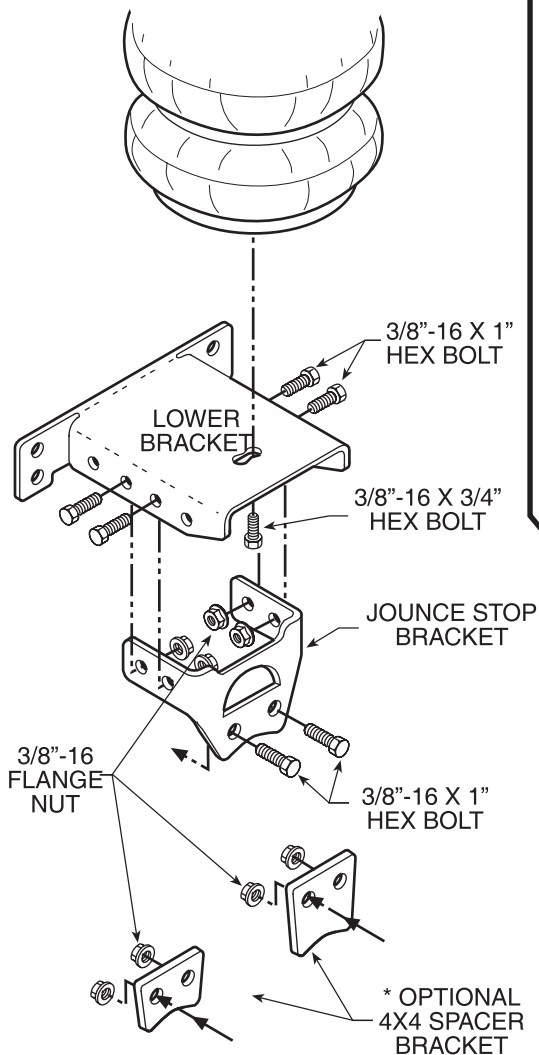

***NOTE:** AN ADDITIONAL SPACER MAY BE NECESSARY FOR SOME 4X4's. IF THE SPACER IS REQUIRED, USE THE SPACER THAT BEST FITS THE VEHICLE.

KIT TO VEHICLE INSTALLATION

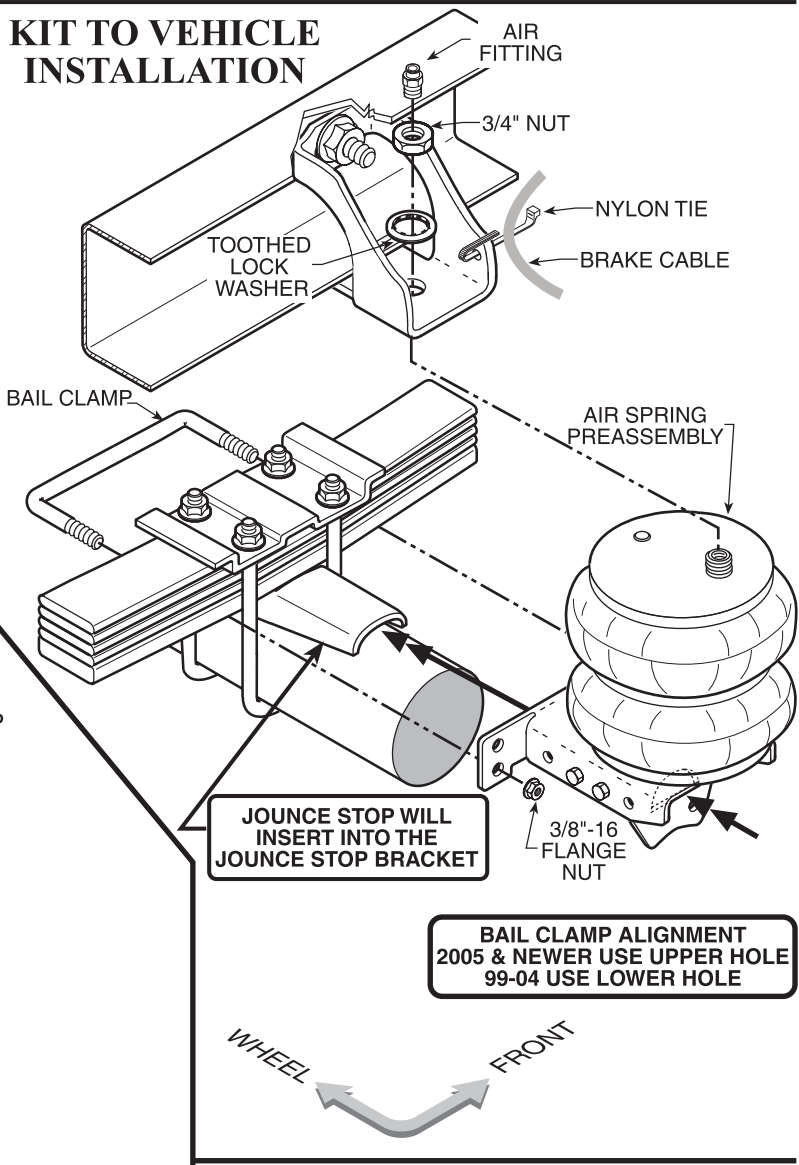

JOUNCE STOP WILL INSERT INTO THE JOUNCE STOP BRACKET

BAIL CLAMP ALIGNMENT
2005 & NEWER USE UPPER HOLE
99-04 USE LOWER HOLE



NOTE: KIT INSTALLATION WILL VARY BETWEEN YEARS AND MODELS. PLEASE READ INSTRUCTIONS CAREFULLY.

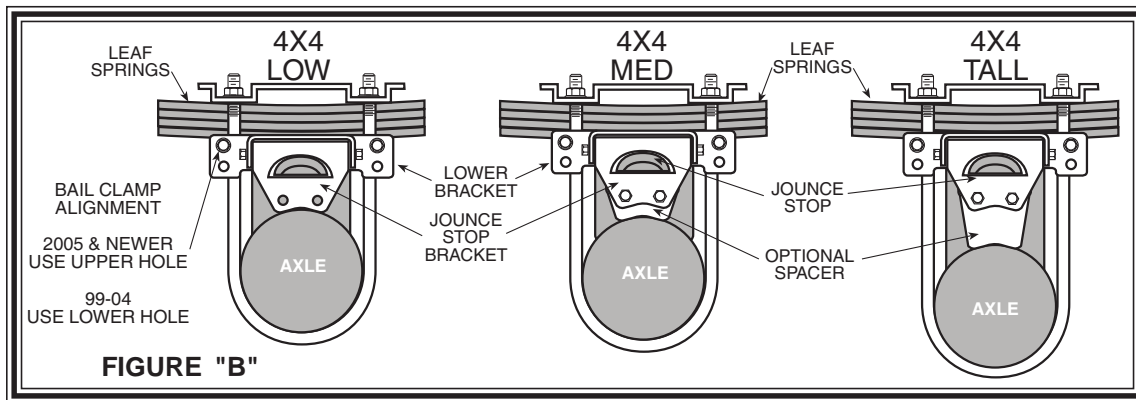

FIGURE "B"

STEP 1 - PREPARE THE VEHICLE

On 2005 and newer vehicles some lines must be repositioned on the left side of the vehicle. Remove the nut holding the fuel line retaining clip. Rotate the retaining clip 90 degrees with the stud facing down. Install the relocating bracket with the nut previously removed. Next, fasten the retaining clip to the relocation bracket using a 5/16"-24 x 3/4" bolt and 5/16"-24 flange nut.

Your vehicle is equipped with rubber jounce bumpers attached to the frame directly above the axle. Remove these bumpers by un-bolting from the inside of the frame flange. These bumpers will not be re-used with this kit.

STEP 2 - UPPER BRACKET INSTALLATION

Insert the 3/8"-16 x 2-1/2" flat head bolt into the upper bracket and then slide the spacer over the bolt. Install the upper bracket onto the frame. Make sure that no part of the vehicle's wiring will be pinched between the upper bracket and the frame. Tighten the 3/8"-16 flat head bolt with a 3/8"-16 flange nut and the large 3/8" washer. Install the 3/4"-16 x 3" hex bolt thru the existing hole in the frame rail and upper bracket. Secure the 3/4" bolt with a 3/4" flat washer, 3/4" lock washer and, 3/4" hex nut.

If you have existing hitch hardware, the 3/4" bolt should be long enough to extend thru the upper bracket, truck frame and the hitch brackets (if present). Be sure to use at least one of the large flat washers and lock washer before putting the 3/4" nut onto the bolt. Finally, the emergency brake cable will have to be tie-wrapped out of the way using the hole provided in the upper bracket. See Figure "A".

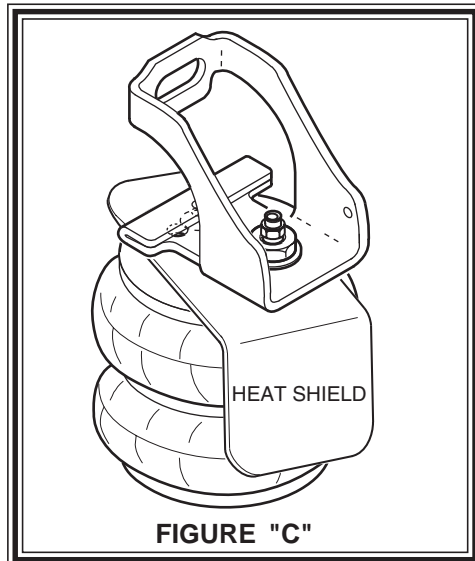

FIGURE "C"

STEP 3 - LOWER BRACKET INSTALLATION

Fasten the lower bracket to the bottom of the air spring finger tight. Next, install the jounce stop bracket onto the lower bracket using four 3/8"-16 x 1" bolts and 3/8"-16 flange nuts. **NOTE: There is a LEFT and RIGHT jounce stop bracket.** Be sure to capture the jounce bumper tongue with this bracket. If the jounce stop bracket does not touch the axle a spacer bracket will have to be used. If there is a small gap, use the short spacer, or the long spacer for a large gap. See Figures "A" & "B".

Install the spacer bracket using two 3/8"-16 x 1" bolts and 3/8"-16 flange nuts. Install the bail clamp around the axle perch and install the 3/8"-16 flange nuts onto the bail clamp and tighten. Finally tighten up the 3/8"-16 flange bolt into the air spring. See Figures "A" & "B".

STEP 4 - AIR SPRING INSTALLATION

The heat shield will be used on the right side of the truck where the exhaust pipe is closest to the air spring. It is placed between the upper bracket and the top of the air spring. The top of the air spring has a button which will be put into the hole in the upper bracket towards the front of the truck on both sides.

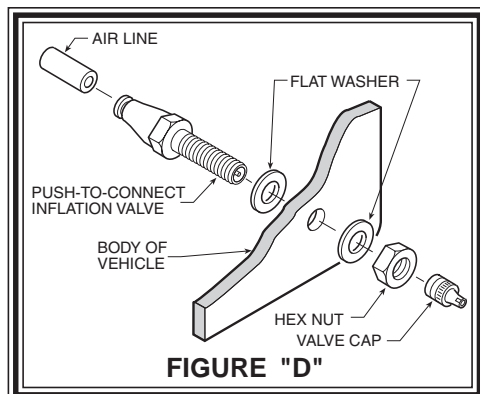

FIGURE "D"

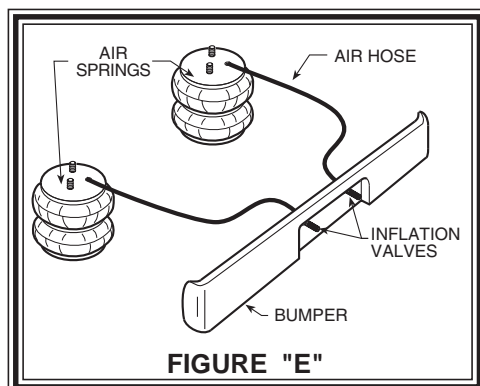

FIGURE "E"

When the air spring is in place and properly lined up, place the internal tooth lock washer and the 3/4" hex nut onto the top stud of the air spring. On the right side move the heat shield into alignment before tightening the top nut on the air spring. Make sure the heat shield will not interfere with the normal operation of the air spring or the vehicle's suspension. Do not position the face of the shield directly over the axle, as it may contact the axle on full suspension compression. *See Figure "C"*.

Install the air fitting into the top stud of the air spring. Tighten the air fitting securely to engage the orange thread sealant.

STEP 5 - AIR LINE INSTALLATION

Uncoil the air tubing and cut it into two equal lengths. *DO NOT FOLD OR KINK THE TUBING*. Try to make the cut as square as possible. Insert one end of the tubing into the elbow fitting installed in the top of the air helper spring. Push the tubing into the fitting as far as possible.

Select a location on the vehicle for the air inflation valves. This can be on the bumper or the body of the vehicle, as long as it is protected so the valves will not be damaged. Drill a 5/16" hole and install the air inflation valve using two 5/16" flat washers per valve as supports. Route the tubing from the air helper spring to the inflation valve, avoiding direct heat from the engine, exhaust pipe, and away from sharp edges. The air line tubing should not be bent or curved sharply as it may buckle with time. Secure the tubing in place with the nylon ties provided. Push the end of the air line tubing into the inflation valve as far as possible. *See Figures "D" & "E"*.

STEP 6 - CHECK THE SYSTEM

Final inspection. Visually check for loose attaching bolts. Make sure that no part of the truck is rubbing against the air springs. Again, make sure that the truck's brake lines are not pinched or being rubbed by any part of your Ride-Rite™ kit.

Once the inflation valves are installed, inflate the air helper springs to 50 psi and check the fittings for air leaks with an applied solution of soap and water. If a leak is detected, deflate the air spring by depressing the valve core. The tubing can easily be removed from the fittings by pushing the collar towards the body of the fitting while pulling out the tube. Next, check the tubing connection to ensure that the air tubing is cut as square as possible and that it is pushed completely into the fitting.

If a leak is detected where the air fitting screws into the air spring, gently tighten the air fitting into the spring until the leak stops. Also, check the core of the inflation valve. This valve core can be tightened using the cap. Re-inflate the air spring and check for leaks again if needed. This now completes the installation. Reconnect the battery cable and remove the wheel chocks.

NOTE: THE OPERATING PRESSURE OF THIS KIT IS 5 PSI MIN. TO 100 PSI MAX.

Too much air pressure in the air helper springs will result in a firmer ride, while too little air pressure will allow the air helper spring to bottom out over rough conditions. Too little air pressure will also not provide the improvement in handling that is possible. *TO PREVENT POSSIBLE DAMAGE MAINTAIN A MINIMUM OF 5 psi IN THE AIR HELPER SPRINGS AT ALL TIMES.*

Once the air helper springs are installed, it is recommended that the vehicle not be lifted by the frame, as over-extension may occur, resulting in damage to the air helper springs. However, should it become necessary to raise the vehicle by the frame, deflate both air helper springs completely.

NOTE:

MIN PRESSURE

5 PSI

MAX PRESSURE (LOADED)

100 PSI