

OPERATING INSTRUCTIONS AND TROUBLE SHOOTING GUIDE

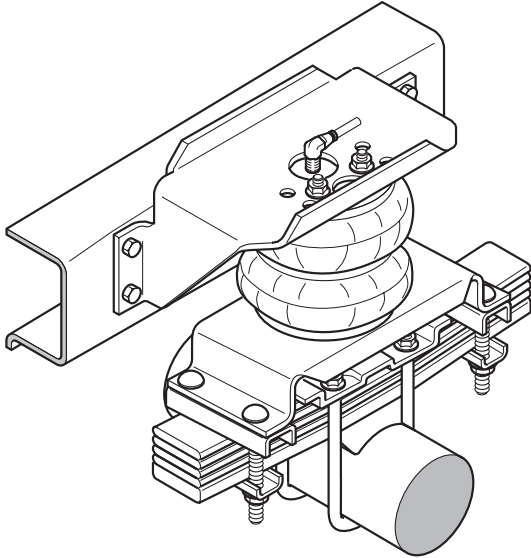

RIDE-RITE™
(2071 Shown)

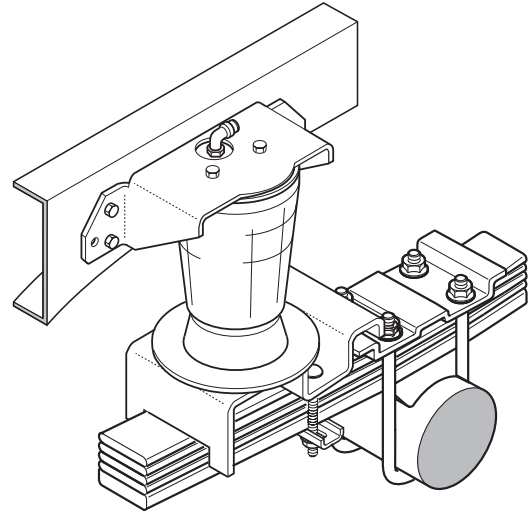

SPORT-RITE™
(2320 Shown)

Thank you for purchasing Firestone air helper springs. You have purchased a quality product from the world's number one air spring manufacturer.

This manual will provide answers to some of your questions regarding the use and operation of your new air helper springs. Following the guidelines in this manual will help provide you with many years of trouble-free service from your Firestone air helper springs.

GENERAL INFORMATION

Firestone air helper springs are heavy duty, quality air springs designed to supplement your vehicle's existing suspension system. These durable air springs allow you to maximize your vehicle's load carrying capacity through the use of air pressure. Proper installation, use, and operation will provide the maximum service life and performance your air spring kit is capable of delivering. These instructions will help you obtain the maximum benefits available from your air spring kit.

RIDE-RITE™ AIR HELPER SPRINGS

Ride-Rite™ air helper springs are installed between the frame and the suspension of light trucks, vans, and motorhomes. Ride-Rite™ air helper springs are capable of carrying loads up to 5000 lbs (*do not exceed the vehicle's GVWR*).

SPORT-RITE™ AIR HELPER SPRINGS

Sport-Rite™ air helper springs are installed between the frame and suspension of light trucks, and utilize a sleeve-style air spring to enhance the ride when the vehicle is loaded or unloaded. Sport-Rite™ air helper springs are capable of carrying loads up to 3000 lbs (*do not exceed the vehicle's GVWR*).

BASIC OPERATION

As your vehicle is loaded, the stock suspension is compressed under the weight of the load. Your vehicle's stock suspension system has been designed so that it will provide optimum performance and handling with a specific load on the vehicle. When your vehicle is loaded, its performance, handling characteristics, and ride quality may be compromised. As the stock suspension is compressed, the ride may become "mushy", and you may encounter sway and handling problems. As weight is added to the vehicle, the air helper springs become an active part of the suspension system. As more air pressure is added to the air springs, they will support more weight. You will be able to compensate for a heavy load by adding air pressure to the air springs, thereby reducing sway and handling problems associated with a heavily loaded vehicle.

SETTING UP YOUR AIR SPRING SYSTEM

After installing Ride-Rite™ /Sport-Rite™ air helper springs to your vehicle, or after purchasing a vehicle equipped with Ride-Rite™ /Sport-Rite™ air helper springs, take a few minutes to establish some basic operating guides. Following these guidelines will ensure optimum performance from your air spring kit:

TORQUE SPECIFICATIONS

Using a torque wrench, torque the threaded fasteners to the following specifications:

- | | |
|--|----------------|
| • Fasteners used on studs and blind holes in air springs | 10 - 15 ft lbs |
| • Hex nuts installed on axle straps | 10 - 15 ft lbs |
| • Hex nuts installed on 3/8" hex bolts | 28 - 32 ft lbs |
| • Hex nuts and bolts used to secure brackets to frame | 28 - 32 ft lbs |
| • Hex nuts installed on U-bolts | 15 - 20 ft lbs |
| • Hex bolts securing 110/70 air spring to lower bracket | 10 - 12 ft lbs |

PREVAILING-TORQUE LOCK NUTS

In order to assure trouble-free operation, your air spring kit includes a variety of self-locking threaded fasteners. Your kit may include prevailing-torque lock nuts. Prevailing-torque lock nuts may be more difficult to install, but will not come loose under normal suspension operation.

THREAD LOCKING COMPOUND

The hex bolts used to secure the air spring to the brackets may have a locking compound applied to the threads. Lock washers are not required when using a fastener with pre-applied thread locking compound. When installing fasteners with thread locking compound, follow the torque recommendations listed above.

HELICAL LOCK WASHERS

Your air helper spring kit may include helical lock washers. In order to properly use the lock washer, tighten the nut/bolt fastener just enough to flatten the lock washer. Overtightening the fastener may damage the nut or bolt. When using helical lock washers, follow the torque recommendations listed above.

AIR FITTINGS

Your kit will include one of two types of push-to-connect air fittings. Ride-Rite™ kits include push-to-connect air fittings with a thread locking compound pre-applied to the fitting's threads. Sport-Rite™ kits include push-to-connect swivel fittings with a nylon collar in place of the thread locking compound.

Ride-Rite™ fittings - To install the air fittings with the pre-applied thread sealant, thread the air fitting into the air spring and tighten the fitting securely to engage the pre-applied thread sealant.

Sport-Rite™ fittings - To install the air fittings with the nylon collar, thread the air fitting into the threaded hole on the air spring so that the nylon collar makes contact with the top of the air spring and then tighten 1/4-1/2 turn. No thread sealant is required.

Both types of air fittings allow easy connection between the air fitting and the air line tubing. To install the air line in the fitting, cut the tubing as square as possible using a sharp utility knife or razor blade. Push the air line into the fitting as far as possible. If the tubing must be removed from the fitting, first release the air pressure from the air spring. Push the collar towards the body of the fitting and then pull the tubing out.

PRESSURE DIFFERENTIAL BETWEEN AIR SPRINGS

It is not uncommon to have a pressure differential between the air springs after the vehicle has been brought to a level condition. If the vehicle is within the manufacturer's recommended gross vehicle weight and you have not achieved a level condition after inflating the air springs to 80 psi, there may be a problem with your stock suspension. The leaf springs may have become fatigued over time or a leaf spring may be fractured. There may be an obstruction in the air system, not allowing the air pressure to reach the air helper springs.

AIR SPRING ALIGNMENT

Upon completion of the installation, the air springs should be inspected for proper alignment. Although the air helper springs can function with some misalignment, it is preferred that the air springs be mounted so that they are as aligned as vertically as possible.

AIR SPRING DESIGN HEIGHT

Check the distance between the upper bracket and lower bracket (design height). The dimensions shown on *Page 5* are a guide to assist in determining the ideal operating height for your air helper springs.

INFLATING THE AIR SPRINGS

With the air helper springs installed on your vehicle and the vehicle sitting on a level surface, visually verify that the vehicle is in a level state. If the vehicle is not level (front-to-back or from side-to-side) it can be brought to a level position by inflating the air springs using an air source equipped with an air chuck. (If your vehicle is equipped with a cab control or automatic height control system, refer to that device's installation instructions.) Each air spring has a separate inflation valve. To level the vehicle from front-to-back, add air pressure to both air springs in equal amounts. To level the vehicle from side-to-side, add more air pressure to the air spring on the lower side of the vehicle. When inflating the air springs, add air pressure in small quantities, checking the pressure frequently. The air spring requires much less air volume than a tire, and therefore, will inflate much more quickly. *Warning: DO NOT EXCEED 100psi IN EACH AIR SPRING.*

LEVELING THE VEHICLE

Take your loaded vehicle to your local service station and park on a level spot near the air pump. Check the level of your vehicle visually. If it is not level, either from front to back or from side to side, level it by inflating your air springs. (If your vehicle is equipped with a cab control unit or automatic control system refer to the directions for that device.) There is one inflation valve for each air spring. To level from front to back, add air pressure to both air springs equally. For side to side, add air pressure to the air springs on the side of the vehicle that is low. When adding air pressure to the air springs, remember that they have a much smaller volume of air than a tire so they will inflate much quicker. Add air pressure in short bursts until the vehicle is level. (NEVER EXCEED 100psi IN EACH AIR SPRING.)

STORAGE

When storing an RV over long periods of time, inflate the air helper springs to 80 - 90 psi. The air springs will carry some of the vehicle's weight and reduce leaf spring fatigue during storage.

SAFETY TIPS

Never exceed the manufacturer's recommended Gross Vehicle Weight Rating (GVWR)

As with your vehicle's tires, an air helper spring is a pneumatic device that supports a portion of the vehicle's weight. The air helper spring may fail as a result of punctures, impact damage, improper inflation, improper installation, or improper usage. To reduce the risk of failure, we strongly recommend the following:

1. Inspect the inflated air springs to verify that they do not contact any component of the vehicle under normal suspension operation. The air helper spring must flex and expand during normal operation. There must be at least 1/2" of clearance between the inflated air spring and any other component of the vehicle under normal suspension operation.
2. Inspect the air line tubing and the air spring to verify that they have not been damaged due to exposure to heat from the exhaust system. If the distance between any portion of the air spring and the exhaust system is less than 6", a heat shield should be used.
3. **Never overload your vehicle.** The manufacturer's gross vehicle weight rating (GVWR) is stated on the specification plate on the chassis. You should weigh your vehicle on a truck scale when it is fully loaded and in a level condition to determine if you are exceeding the manufacturer's recommended GVWR.
4. Never inflate the air helper springs beyond 100 psi.
5. Never attempt to remove any component of the air spring assembly when the air springs are inflated.
6. If an air helper spring has failed while you are on the road, operate your vehicle at reduced speeds. High speed over rough roads will result in severe bottoming of the air spring and may damage other vehicle components.
7. Never attempt to drive the vehicle in an un-leveled condition. Failure to level a heavily loaded vehicle may result in excessive body roll and possible damage or injury.
8. If unidentifiable problems exist with your air helper spring kit, visit Firestone on the web at www.ride-rite.com for technical assistance.
9. Never cut, weld, or modify the air helper springs or brackets.
10. Do not use aerosol tire repair products in the air helper springs. If there is a hole in the air spring it must be replaced.
11. Do not use a tire patch of any kind on the air helper spring. If there is a hole in the air spring it must be replaced.

MAINTENANCE

The following will help obtain the maximum service life from your air helper springs:

1. It is considered normal for air helper springs to lose some air pressure over time. Normal pressure loss should not exceed 3 - 4 psi per week when the air springs are inflated to 50 psi. If the pressure loss is greater than 3 - 4 psi per week, there may be a leak in the system. Each time you check the pressure in the air springs, you will lose 3 - 5 psi. The air pressure should be checked at regular intervals. Establish an interval to check the air springs by first inflating them to the pressure required for your application. Check the air pressure after one week. If there is no pressure loss, check the air pressure after two more weeks. Again, if there is no pressure loss, check the air pressure after three more weeks. Continue to lengthen the time period until you detect a loss in air pressure. The time it takes to lose air pressure will determine how often you should check the pressure in the air springs.

It is recommended that the air pressure be checked according to the following guidelines:

- A. When the vehicle is removed from long-term storage
- B. At regular intervals during the continuous operation of the vehicle (see above)
- C. If the air springs are used to assist in leveling an RV or camper on uneven ground, ensure that the vehicle is returned to a level ride height before departing.

3. The brackets used to secure the air helper spring to the vehicle should be inspected periodically for damage and for loose fasteners. Ensure that the air line tubing is clear of any sharp edges and routed away from the exhaust system. The brackets and air line tubing should be inspected every 6 months. Ensure that the threaded fasteners are torqued to the specifications listed on *Page 2*.

4. Accumulated sand, gravel, or other road debris on the air springs or brackets should be rinsed away with a garden hose each time the vehicle is washed.

5. If it is necessary to lift the vehicle by the frame, first release the air pressure from the air springs. This will allow the air springs to extend to their maximum length without being damaged. The uninflated air springs are capable of supporting the weight of the axle when the vehicle is lifted by the frame. After servicing of the vehicle is complete, lower the vehicle to the ground and reinflate the air helper springs to the desired pressure. On Sport-Rite kits the air helper springs must be aired up to 50 psi and then release the air until the air helper springs are to the desired pressure.

TECHNICAL DATA

Proper installation of the air helper spring kit is important to obtaining all of the benefits your kit is capable of delivering. The air spring must be attached to the vehicle so that it is aligned as close to vertical as possible. The air spring kit must be installed so that the distance between the upper and lower brackets is within a specific range. Refer to the chart on page 5 to determine the proper air spring mounting height and air pressure range for your application.

AIR SPRING TECHNICAL DATA

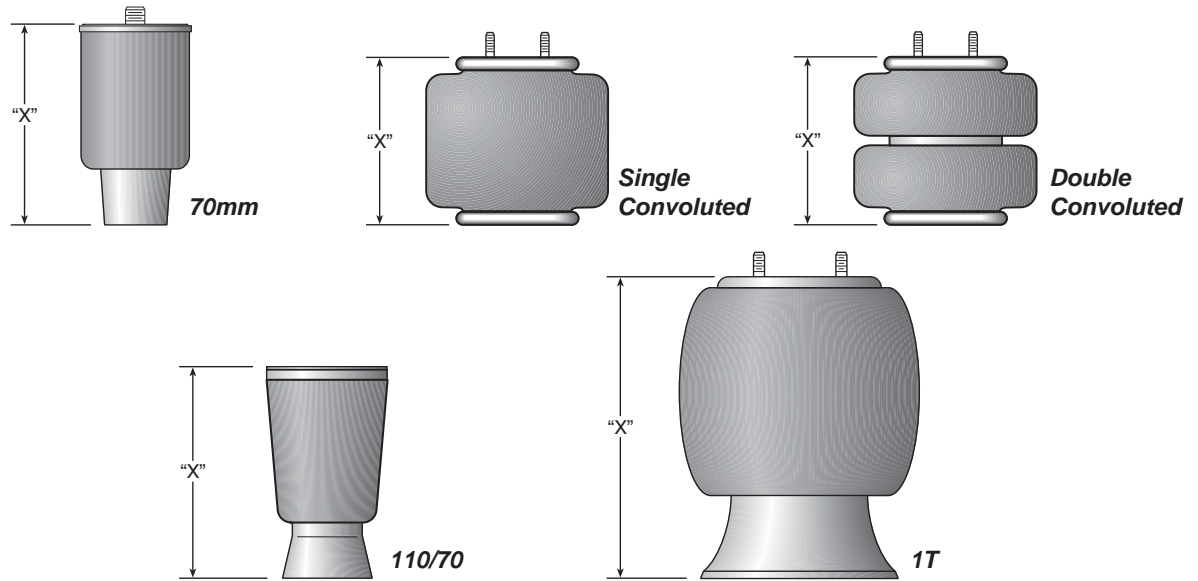

PART NUMBER	DESCRIPTION	TYPE	"X" DIMENSION	MIN / MAX AIR PRESSURE	MAX LOAD @ 100 PSI (PER PAIR)
1132	Single Convoluted	116B-1	4" - 5"	5 / 100 psi	3000 lbs
6762	Double Convoluted	268C	4" - 5"	5 / 100 psi	3200 lbs
6764	Double Convoluted	268C	4" - 5"	5 / 100 psi	3200 lbs
6766	Double Convoluted	268C	4" - 5"	5 / 100 psi	3200 lbs
6397	Double Convoluted	267C 1.5	4-1/2" - 6-1/2"	5 / 100 psi	4800 lbs
6781	Double Convoluted	267C 1.5	4-1/2" - 6-1/2"	5 / 100 psi	4800 lbs
0335	Double Convoluted	224C	4-1/2" - 6-1/2"	5 / 100 psi	5000 lbs
6401	Double Convoluted	224C	4-1/2" - 6-1/2"	5 / 100 psi	5000 lbs
7325	Double Convoluted	26C	5" - 7"	5 / 100 psi	5640 lbs
2107	1T Style	1T14C-1	7" - 11"	10 / 100 psi	6400 lbs
5405	1T Style	1T14C-3	8" - 12"	10 / 100 psi	6400 lbs
7076	Reversible Sleeve	70MM	6" - 8"	10 / 100 psi	2000 lbs
9000	Tapered Sleeve	110/70 Tall	7-1/4" - 8-3/4"	10 / 100 psi	3000 lbs
9002	Tapered Sleeve	110/70 Medium	6-3/4" - 8"	10 / 100 psi	3000 lbs
9001	Tapered Sleeve	110/70 Short	5-3/4" - 6-3/4"	10 / 100 psi	3000 lbs

This information is provided for reference purposes only. The bracketry and air springs in the Ride-Rite™ and Sport-Rite™ kits are designed to work with the original suspension and within the manufacture's Gross Vehicle Weight Rating (GVWR) for the intended vehicle. Brackets and air springs should not be interchanged or modified.

TROUBLE SHOOTING GUIDE

Air spring will not inflate

Ensure that the air line tubing is inserted into the air fittings as far as possible.

Clear any dirt or debris from inside the inflation valves.

Inspect the entire length of air line tubing to ensure that it is not kinked, damaged from exhaust heat, or cut due to contact with sharp edges

Air spring will not hold air

Normal pressure loss is no more than 3 - 4 psi per week when the air spring is inflated to 50 psi..

Using the inflation valve cap as a core tool, ensure that the valve core is installed securely.

Apply a solution of soap and water to the air fittings, air line, and air springs to check for leaks. Tighten the air fitting or re-install the tubing in the air fitting to stop the leak. Rinse the soap and water solution from the system when complete.

The vehicle is not level

Check for proper inflation of the air springs on each side of the vehicle.

Check for obstructions in the air system or vehicle components that may be restricting suspension travel.

Finding a stubborn leak

If a leak can not be detected with the soap and water solution, deflate the air springs and remove them from the vehicle. Re-install the tubing and inflation valve on the air spring and inflate the air spring to a maximum of 20 psi. Submerge the air spring in a bucket of water to check for leaks.

Common locations of air leaks

Leaks occur most often at the threaded connection between the air fittings and the air springs. Tighten the fitting to engage the pre-applied orange thread sealant or until the nylon collar makes contact with the air spring, plus 1/4-1/2 turn, depending on which type of fitting is included in your kit. (See air fittings on page 3)

The end of the air line tubing must be cut square and clean to avoid burrs in the connection to the air fittings. The push-to-connect fittings require a square cut to properly seal. The tubing can be removed from the fitting by first releasing the air pressure from the air spring. Push the collar on the fitting toward the body of the fitting. While holding the collar in, pull out the tubing. Cut the tubing squarely and push the tubing into the fitting as far as possible.

WARRANTY QUESTIONS

IS A LEAKING AIR SPRING COVERED UNDER WARRANTY?

An air helper spring with a leak does not necessarily indicate that the air spring is defective. Inspect the air spring for obvious punctures or abrasions. A failure caused by a puncture or abrasion to the air spring would not be covered by the material and workmanship warranty. An air helper spring kit that has not been installed according to the published installation manual will not be covered by the warranty. Warranty consideration will only be given if the kit listed in our published application guide is installed on the proper vehicle.

WHAT DO I DO IF I HAVE A DEFECTIVE PART THAT IS COVERED UNDER WARRANTY?

Call the dealer you purchased your air helper spring kit from to address the warranty claim. If the dealer determines that the warranty claim is questionable, you may need to purchase a replacement part until the warranty claim can be submitted and reviewed by Firestone. If the warranty claim is determined to be a valid warranty claim, a credit for the purchased part will be issued.

Firestone

AIR ACCESSORY SYSTEMS

As an option, Firestone has made a variety of Air Accessory Systems available to use in conjunction with your air helper springs.

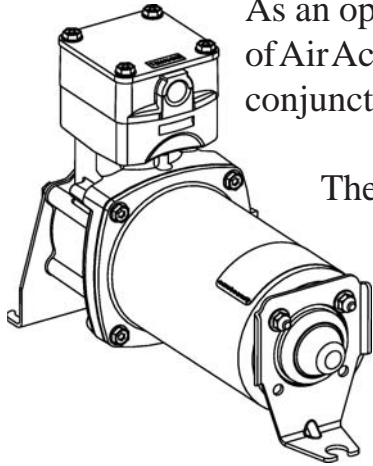

The Air Accessory System provides instant adjustment of your air helper springs. Some of the Air Accessory System options are shown below.

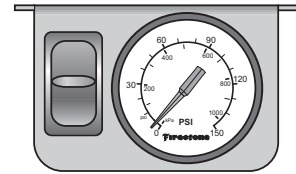

Level Command
WR1-760-2097 (white face gauge)

The *Level Command* kit provides inflation control of the air helper springs from inside the cab and includes a heavy duty air compressor that provides equal inflation for both air springs.

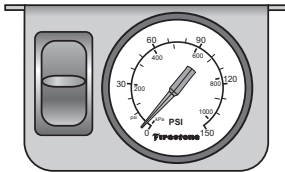

Level Command II
WR1-760-2158 (white face gauge)

The *Level Command II* kit provides inflation control of the air helper springs from inside the cab and includes a standard duty air compressor that provides equal inflation to the air springs.

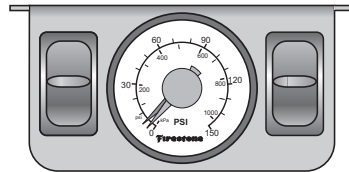

Dual Air Command II
WR1-760-2168 (white face gauge)

The *Dual Air Command II* provides front-to-rear or side-to-side leveling through the use of a dual gauge, heavy duty compressor (9210) and 1/2 gallon air tank. Inflates each air spring individually. (two air springs)

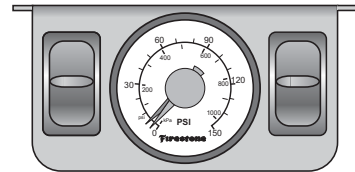

Dual Air Command III
WR1-760-2198 (white face gauge)

The *Dual Air Command III* provides front-to-rear or side-to-side leveling through the use of a dual gauge, super heavy duty compressor (9230) and one gallon air tank. Inflates each air spring individually. (two air springs)

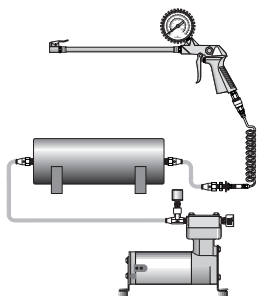

Remote Fill Station
WR1-760-2239

The all new *Remote Fill Station* offers an on-board air source for inflating air springs, tires and other pneumatic components. Ideal for off-road enthusiasts and tow vehicles.

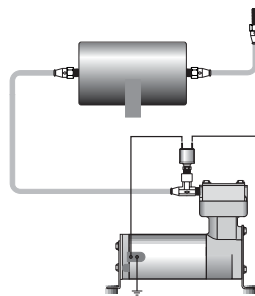

Air Command
WR1-760-2047 (1/2 gallon air tank)
WR1-760-2232 (1 gallon air tank)

The *Air Command* system provides a reliable source of compressed air to inflate your air springs using a heavy duty compressor, 1/2 or 1 gallon air tank, and 25' extension hose.

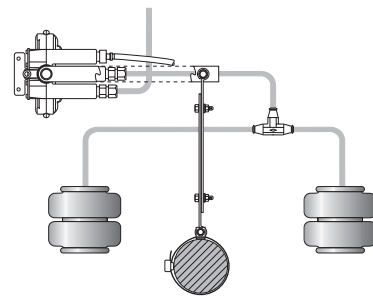

Single Automatic Air Command
WR1-760-2186

The *Single Automatic Air Command* kit inflates both air springs equally through the use of height control valve mounted between the chassis and suspension. (Use in conjunction with 2047, 2232, or 2239)

THANK YOU FOR USING RIDE-RITE™ / SPORT-RITE™ AIR HELPER SPRINGS FROM FIRESTONE.