

## **WARNING!**

Do not inflate this assembly when it is unrestricted. The assembly must be restricted by the suspension or other adequate structure. Do not inflate beyond 100 P.S.I. Improper use or over inflation may cause property damage or severe personal injury.

## **INSTALLATION INSTRUCTIONS**

Congratulations - your new air helper springs are quality products capable of improving the handling and comfort of your vehicle. As with all products, proper installation is the key to obtaining all of the benefits your kit is capable of delivering. Please take a few minutes to read through the instructions to identify the components and learn where and how they are used. It is a good idea to start by comparing the parts in your kit with the parts list below.

The heart of the kit is, of course, the air springs. Remember that the air helper springs must flex and expand during operation, so be sure that there is enough clearance to do so without rubbing against any other part of the vehicle.

Be sure to take all applicable safety precautions during the installation of the kit. The instructions listed in this brochure and the illustrations all show the left, or driver's side of the vehicle. To install the right side assembly simply follow the same procedures.

Your kit includes separate inflation valves and air lines for each air helper spring. This will allow you to level your vehicle from side to side as well as from front to back. If you would rather have a single valve inflation system, your dealer can supply the required "T" fitting.

## **IMPORTANT!**

*For your safety and to prevent possible damage to your vehicle, do not exceed the maximum load recommended by the vehicle manufacturer (GVWR). Although your air helper springs are rated at a maximum inflation pressure of 100 P.S.I., this pressure may allow you to carry too great a load on some vehicles. Check your vehicle owner's manual for maximum loads listed for your vehicle.*

*When inflating your air helper springs, add air pressure in small quantities, checking pressure frequently during inflation. The air spring requires much less air volume than a tire and, therefore, inflates much quicker.*

## **PARTS LIST**

AIR SPRING	6764	2	5/16" -24 X 1" HEX BOLT	2
UPPER BRACKET (LEFT)	5110	1	5/16" -24 FLANGED LOCK NUT	2
UPPER BRACKET (RIGHT)	5111	1	5/16" FLAT WASHER	6
LOWER BRACKET	5156	2	PUSH-TO-CONNECT	
BRACKET STRAP	0530	4	INFLATION VALVE	3032
AIR LINE TUBING - 18 FT	0938	1	PUSH-TO-CONNECT	
HEAT SHIELD	1004	1	STRAIGHT FITTING	3046
3/8"-16 X 3" CARRIAGE BOLT		2	NYLON TIES	6
3/8"-16 X 3-1/2" CARRIAGE BOLT		8	THERMAL SLEVE	2
3/8"-16 FLANGED LOCK NUT		18	CAUTION TAG	2

**FIGURE "A"**

**NOTE:** Both illustrations are of the left, or drivers side, of the vehicle. Reverse any orientations when assembling and installing the right, or passenger, side of the vehicle.

**KIT ASSEMBLY**

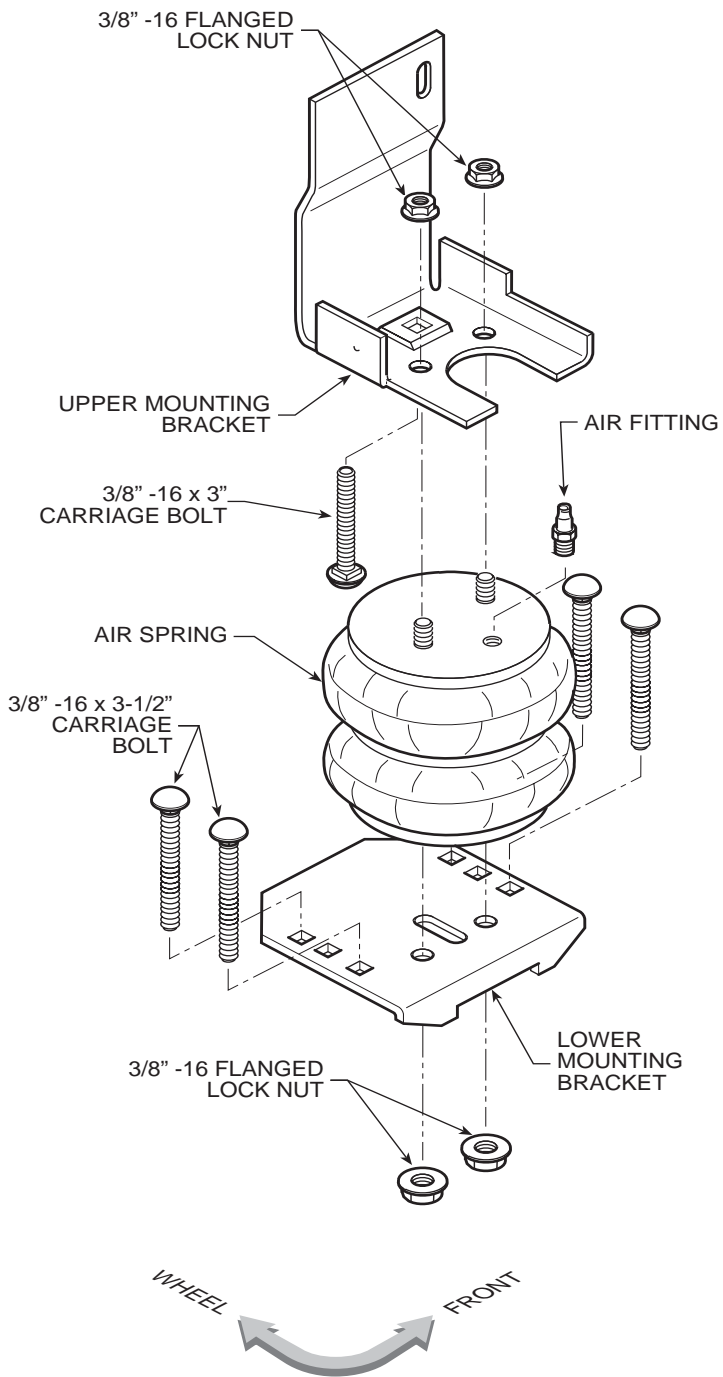

**KIT TO FRAME ASSEMBLY**

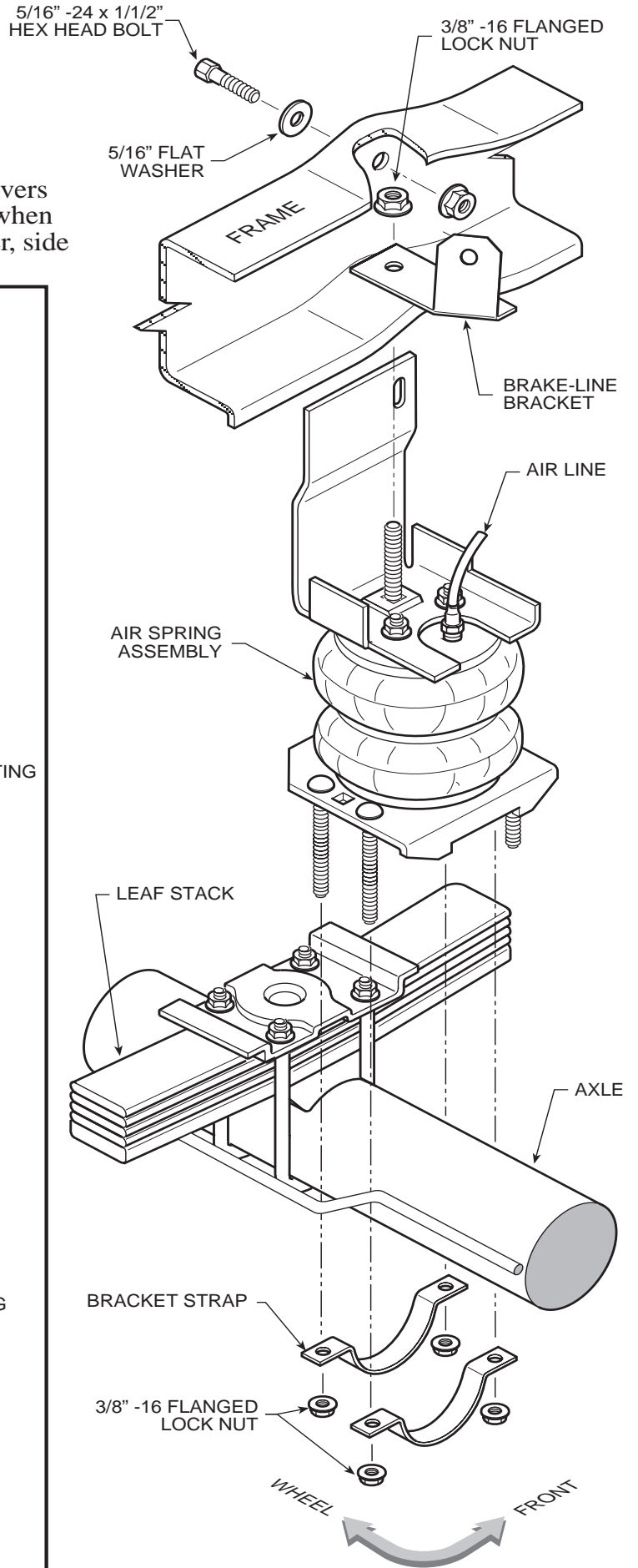

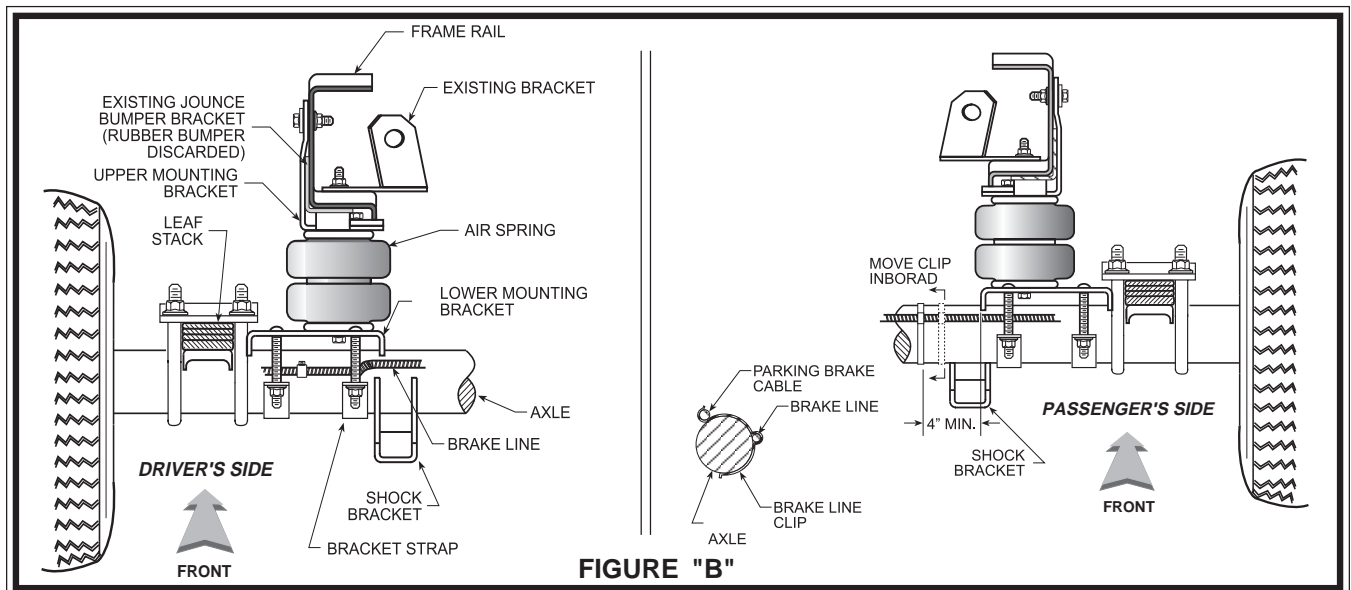

**FIGURE "B"**

### **STEP 1 - PREPARE THE VEHICLE**

Remove the positive battery cable. With the vehicle on a solid, level surface chock the front wheels. Raise the vehicle by the axle and remove the rear wheels. After the removal of the wheels lower the vehicle so the axle rests on jack stands rated to support your vehicles weight.

Your vehicle is equipped with rubber jounce bumpers. The bumpers are attached to the frame directly above the axle. Remove these bumpers by unbolting from the inside of the frame flange. This bumper will not be reused with this kit.

### **STEP 2 - USE OF THE HEAT SHIELD**

Some vehicles may require the use of a heat shield. The shield is used to deflect heat from the air spring. A heat shield should be used if the distance between the exhaust pipe and the air spring is approximately 6" or less. The heat shield is mounted between the upper bracket and the upper plate of the air spring *see Figure "C"*. Position the shield directly between the closest heat source and the air spring. Ensure that the heat shield will not interfere with the normal operation of the air spring or the vehicle's suspension. Do not position the face of the shield directly over the axle, as it may contact the axle on full suspension compression.

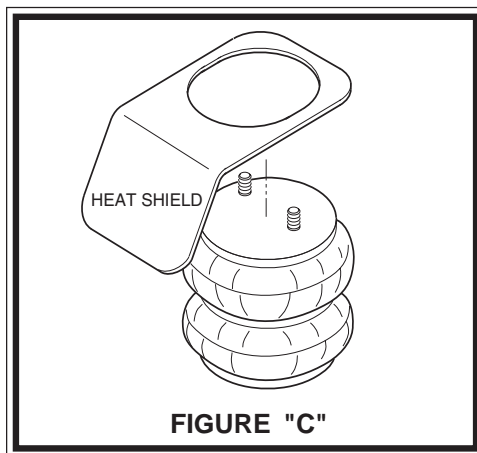

**FIGURE "C"**

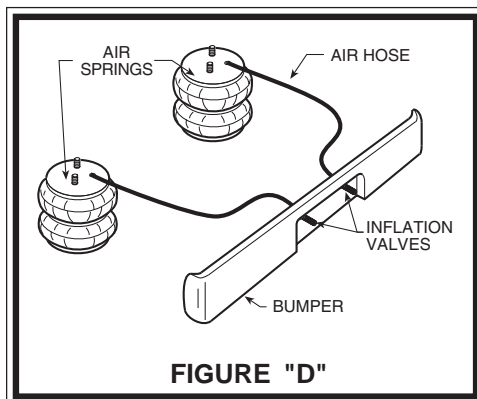

**FIGURE "D"**

### **STEP 3 - BRACKET AND AIR SPRING ASSEMBLY**

This kit contains two different upper brackets, one for the left side and one for the right side. Preassembly will begin with the left (driver's) side of the vehicle. All pictures depict the installation on the left side unless noted otherwise. Start by selecting the upper bracket for the left side *see Figure "A"*. Install one 3/8" -16 x 3" carriage bolt into the upper bracket *see Figure "A"*. Next, select one of the air springs and install the push-to-connect air fitting in the top threaded hole in the air spring and tighten securely. Thread sealant has been pre-applied to the threads of the fitting so no additional sealant is required. Secure the upper bracket to the air spring by using 3/8" -16 flanged lock nuts. Check to make sure that the carriage bolt is still seated properly in the recessed square hole of the upper bracket. Next, select a lower bracket and insert the carriage bolts into the square holes. Secure the lower bracket to the air spring assembly using 3/8" -16 flanged lock nuts *see Figures "A" & "B"*. The lower bracket is the same for the left and right sides. Double-check the orientation of both brackets before attempting installation.

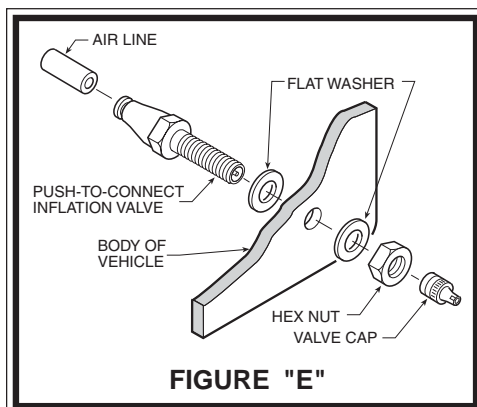

**FIGURE "E"**

#### **STEP 4 - INSTALLATION OF THE ASSEMBLY TO THE VEHICLE**

Compress the air spring to allow for ease of installation. Insert the 3" carriage bolt from the upper bracket assembly through the hole provided by the removal of the jounce bumper. Make sure that the brake-line bracket is inserted over the carriage bolt. Place the lower bracket on top of the axle and position it so that it is flush against the U-bolts that secure the axle. Once properly positioned, fasten the upper bracket to the frame using a 3/8" -16 flanged lock nut with the 3" carriage bolt inserted through the jounce bumper hole. Additionally, insert a 5/16" -24 x 1-1/2" hex bolt and flat washer in the hole on the upper leg of the upper bracket and through the frame. Secure using a 5/16" -24 flanged lock nut *see Figure "A"*. Fasten the lower bracket to the axle housing using the bracket straps and 3/8" -16 flanged lock nuts *see Figures "A" & "B"*. The lower bracket should fit without altering the brake lines. However, if the brake lines are touching the bracket, it may be necessary to reposition the line to avoid contact with the bracket. Once the assembly is in place, make sure that no other carriage component is touching the air spring. You must maintain a minimum of 1/2" clearance around the air spring for proper operation.

#### **STEP 5 - INSTALL THE RIGHT SIDE ASSEMBLY**

Follow the same procedures as outlined in steps 1 through 5 for installing the right side (passenger side) assembly. The brake line clip located on the passenger side of the axle may interfere with the air spring assembly and may need to be repositioned. Slide the clip along the axle *see Figure "B"* to provide at least 4" of clearance between the lower bracket and the clip. In addition, ensure that the heat shield and tubing protectors are installed to provide heat protection.

#### **STEP 6 - INSTALL THE AIR LINE**

Select a location on the vehicle for the inflation valves. The locations can be on the bumper or the body of the vehicle, but be sure that it can be protected so that the valve will not be damaged and will still be accessible for the air chuck *see Figure "D"*. Drill a 5/16" hole and install the inflation valve using two 5/16" flat washers per valve *see Figure "E"*.

Run the tubing from the air spring to the valve. Make sure that all cuts of the tubing are made as square as possible. Route the tubing so that it will be protected from direct heat from the muffler and tail pipe and away from sharp edges. Tubing protectors have been provided for these conditions. The air line tubing should not be bent or curved sharply as it may buckle with age. Secure the tubing in place with the nylon ties provided. Attach the end of the air line tubing to the inflation valve as shown *see Figure "E"*. Push the tubing into the fitting as far as possible. The tubing can be removed from the fitting by pushing the collar back toward the body of the fitting and pulling the tubing out.

#### **STEP 7 - CHECK THE AIR SYSTEM**

Once the inflation valves are installed inflate the air helper springs to 70 P.S.I. and check the fittings for air leaks with an applied solution of soap and water. If a leak is detected at a tubing connection then check to make sure that the tube is cut as square as possible and that it is pushed completely into the fitting. The tubing can easily be removed from the fittings by first releasing the pressure from the air spring followed by pushing the collar towards the body of the fitting and then pulling out the tube. If a leak is detected where the air fitting screws into the spring, remove the tubing by pushing the collar towards the body of the fitting and then pulling out the tube, then screw the air fitting into the air spring one additional turn or until the leak stops. Reinstall the tubing and reinflate the air springs and check for leaks as noted above.

This now completes the installation. Install the wheels and torque the lug nuts to the manufactures specifications. Raise the vehicle by the rear axle and remove the jack stands and lower the vehicle back onto the ground. Re-attach the positive battery cable and remove the wheel chocks from the wheels. Before proceeding, check once again to be sure you have proper clearance around the air springs. With a load on your vehicle and the air helper springs inflated, you must have at least 1/2" clearance around the air springs. As a general rule, the air helper springs will support approximately 40 lbs. of load for each P.S.I. of inflation pressure (per pair). For example, 50 P.S.I. of inflation pressure will support a load of 2000 lbs. per pair of air helper springs. *FORBESTRIDE* use only enough air pressure in the air helper springs to level the vehicle when viewed from the side (front to rear). This amount will vary depending on the load, location of load, condition of existing suspension and personal preference.

#### **NOTE:**

Too much air pressure in the air helper springs will result in a firmer ride, while too little air pressure will allow the air helper spring to bottom out over rough conditions. Too little air pressure will also not provide the improvement in handling that is possible. ***TO PREVENT POSSIBLE DAMAGE MAINTAIN MINIMUM AIR PRESSURE IN THE AIR SPRINGS AT ALL TIMES. Listed below are minimum air pressure requirements.***

**MINIMUM PRESSURES:**      **CLASS "C" MOTORHOMES - 30 p.s.i.**                      **VANS - 5 p.s.i.**

**MAX PRESSURE (ALL) - 100 p.s.i**

#### **NOTE:**

Once the air helper springs are installed, it is recommended that the vehicle not be lifted by the frame, as over-extension may occur, resulting in damage to the air helper springs. However, should it become necessary to raise the vehicle by the frame, deflate both air helper springs completely.

Learn more about performance suspension parts we have.