

Firepower®

Firepower®, a division of Victor Technologies™, is comprised of many of the most respected market leading brands in the welding and metal fabricating industry. Our product lines include: oxy-fuel welding and cutting torches; regulators; plasma arc cutting; MIG, STICK and TIG welding systems; a full line of filler metals; safety equipment and welding accessories.





VICTOR TECHNOLOGIES™ ADVANTAGE

Who We Are:

Victor Technologies, Inc. is a company comprised of strong brands known for their authenticity, innovation and a deep connection with end users. These brands include:

- **Victor®**: With a deep history of safety, performance and reliability, Victor continues to be one of the most demanded gas regulators and torches in the world.
- **Tweco®**: Superior durability and high productivity make Tweco a world leader in MIG guns and consumables.
- **Thermal Dynamics®**: The innovator of manual plasma cutting technology, Thermal Dynamics plasma systems meet and exceed the performance demanded by professionals.
- **Thermal Arc®**: Featuring the latest technology in welding, Thermal Arc welding systems offer unmatched features and usability.
- **TurboTorch®**: The original and #1 brand name in air-fuel torches, TurboTorch is the brand demanded by professionals.
- **Firepower®**: A complete line of cutting and welding equipment and accessories with a heritage of performance, reliability and value.

When you choose our products, expect them to offer unparalleled performance, superior productivity and built-to-last dependability in professional end-user applications, such as Automotive, Construction, Farm and Ranch, Maintenance and Repair, Mechanical Contractors, Metal Art and Jewelry, Vocational Training and Education, and Transportation.

Why Choose Victor Technologies?

- Leading application solutions.
- Victor Technologies' products offer features demanded in today's market, including ease-of use and ergonomic design.
- Victor Technologies' products offer the best warranty in the Industry and is backed by knowledgeable technical support.
- Victor Technologies continues to come to market with new product innovations backed by market research and end-user feedback, providing product features and performance demanded by today's professionals.
- Victor Technologies has a strong history of providing products, programs and promotions, driving sales opportunities year after year.
- Victor Technologies' Firepower brand is long-established in the Automotive Aftermarket, Farm, MRO and Tool and Equipment markets.

Victor Technologies is committed to superior quality products and service. Victor Technologies is ISO 9001:2000 certified and our branded products are tested and certified by independent, accredited agencies including UL, CSA and ETL as applicable.



Machines Chart	2
<i>Section 1 – Gas Equipment and Accessories</i>	
OxyFuel System Solutions	4-5
OxyFuel Outfits	6-7
OxyFuel Regulators	8-9
OxyFuel Singles	10
OxyFuel Accessories Hoses, FBA & Tanks	11
OxyFuel Tips, Nozzles & Welding Rods	12-13
OxyFuel Adapters, Flow Gauge & Air-Fuel Tanks	14
OxyFuel Accessories Eyewear	15
AirFuel Torches	16-17
<i>Section 2 – Manual Plasma Systems, Torches and Accessories</i>	
Plasma Cutting Machines	19-25
Plasma Cutting Consumables & Accessories	26-27
<i>Section 3 – Arc Welding Equipment and Accessories</i>	
MIG/Flux Cored Welders	29-37
MIG Guns, Consumables & Accessories	38-44
STICK/TIG Welders	45-51
Manual Welding Equipment	52-54
<i>Section 4 – Filler Metal</i>	
Electrodes	56-60
Welding Wire	61-62
Welding Rods	63-64
Solder & Flux	65
<i>Section 5 – Accessories</i>	
Safety	67-74
Tools	75-82
Brushes and Abrasives	83-96
<i>Statement of Warranty</i>	98



MACHINES CHART

Machines at a Glance

Gas Equipment

Model	Type	Page
Firepower®	OxyFuel Outfits	6-7
	AirFuel Equipment	16-17

Plasma Systems

Model	Part No.	Page	Weight	Requires Shop Air	Input Voltage	Rated Amps	Rated Cycle Duty	Maximum Thickness
AirCut™ 15C	1-1110-1	19	29 lbs.	No	120V	15 Amps	35%	3/16"
Cutmaster® 42	1-4200	20	26 lbs.	Yes	120-230V	40 Amps	40%	5/8"
Cutmaster 52	1-5130-1	21	43 lbs.	Yes	208-230V	60 Amps	40%	1-1/8"
Cutmaster 82	1-1130-1	22	43 lbs.	Yes	208-230V	80 Amps	40%	1-1/2"
CutSkill® C-20A	1-1625	23	44 lbs.	Yes	120-230V	20 Amps	30%	3/8"
CutSkill C-35A	1-1635-1	24	44 lbs.	Yes	230V	35 Amps	35%	1/2"
Cutskill C-70A	1-1670-1	25	66 lbs.	Yes	230V	70 Amps	35%	1"

TIG • Arc/Stick • GTAW • SMAW • Welders

Model	Part No.	Page	AC	DC	Input Voltage	Rated Amps	Rated Cycle Duty	Maximum Thickness
95 S Inverter	W1003202	45	No	Yes	115V	90 Amps	20%	1/4"
161 S	W1003602	46	No	Yes	11/208-230V	160 Amps	30%	5/8"
201 TS	W1003801	47	No	Yes	115/208-230V	200 Amps	20%	5/8"
FP-100	1443-0412	49	Yes	No	120V	65 Amps	15%	3/16"
FP-235 AC/DC	1443-0416	50	Yes	Yes	230V	200 Amps	20%	1/2"
Thermal Arc® 186 AC/DC	W1006301	51	Yes	Yes	208/230V	200 Amps	20%	1/4"

MIG • GMAW • Flux-Cored • FCAW • Welders

Model	Part No.	Page	Flux Cored	MIG	Input Voltage	Rated Amps	Rated Cycle Duty	Maximum Thickness
Fabricator® 141i	W1003141	29	Yes	Yes	115V	140 Amps	20%	3/16"
Fabricator 181i	W1003181	30, 31	Yes	Yes	230V	180 Amps	20%	1/4"
Fabricator 211i	W1004201	32	Yes	Yes	230V	210 Amps	20%	1/2"
Fabricator 252i	W1004401	33	Yes	Yes	230V	300 Amps	40%	1/2"
FP-95	1444-0322	34	Yes	No	120V	80 Amps	15%	3/16"
FP-125	1444-0324	34	Yes	Yes	120V	88 Amps	20%	1/4"
FP-135	1444-0326	35	Yes	Yes	120V	90 Amps	40%	1/4"
FP-165	1444-0328	36	Yes	Yes	230V	130 Amps	20%	3/8"
FP-260	1444-0312	37	Yes	Yes	230V	200 amps	60%	5/8"



Gas Equipment

Firepower® Products

Victor Technologies™, a leader in metal cutting, gas control and specialty welding solutions, is meeting the needs of people who demand professional-quality results, through a refined portfolio of Firepower branded products. These products represent the leading edge in design, performance, quality and safety, backed by 100 years of proven innovation.

Performance, Value and Ease of Use

The latest Firepower OxyFuel range offers superior performance, excellent value and ease-of-use that helps the craftsman get the job done right the first time. The torch and regulator range is the heart of this new family, with system solutions and components designed for individual needs.

This product range will perform a wide spectrum of tasks, from brazing sheet metal to cutting up to six inch thick steel. Professionals from auto repair, construction, farm/ranch, skilled trades and serious do-it-yourselfers will find the superior solutions they need.

Firepower draws on the heritage and quality of Victor® gas equipment, and has the advantage of utilizing that excellence in product support, service, and application know-how.

CUTTING

ACETYLENE CUTTING TIPS



OxyFuel 350
SERIES 1
or
OxyFuel 250
SERIES 3

NATURAL GAS CUTTING TIPS



OxyFuel 350
SERIES 1
or
OxyFuel 250
SERIES 3

*NOTE: For use with fuel gas other than Acetylene, proper tips, regulators or T-grade hoses may be required.

HEATING



#4 - 0323-0270

#6 - 0323-0271

WELDING

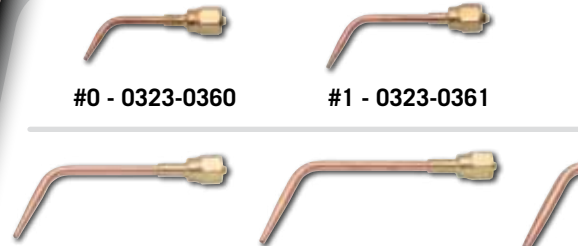

#0 - 0323-0360

#1 - 0323-0361

#3 - 0323-0363

#4 - 0323-0364

OxyFuel Regulators

OXYGEN



0781-9829

ACETYLENE



0781-9830

Full range of Cutting, Heating and Welding products for multiple gas types.

A flexible and versatile platform catered to applications from brazing thin sheet metal to cutting six inch thick steel we have the solution...

PROPYLENE CUTTING TIPS



OxyFuel 350 SERIES 1
or
OxyFuel 250 SERIES 3



0381-0760



0381-0759



#8 - 0323-0272

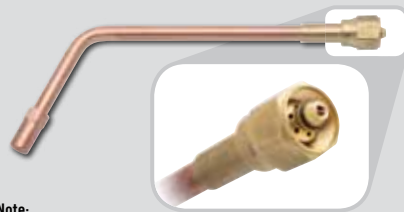

#2 - 0323-0362

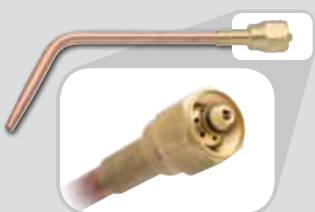

#5 - 0323-0365

Note:

1. "W" Nozzles Fits 7/8" Thread OxyFuel 250-350 Handles
2. "W-1" 5/8" Thread OxyFuel 150 Nozzles Also Available

Note:

1. "W" Nozzles Fits 7/8" Thread OxyFuel 250-350 Handles
2. "W-1" 5/8" Thread OxyFuel 150 Nozzles Also Available
3. Heating Nozzles Are Not Recommended For Use With Tote Outfits, 0916-0032 and 0916-0033 Tanks.



0382-0358
OXYFUEL 250/350 HANDLE



0656-0008
FLASHBACK ARRESTORS

OxyFuel Outfits

250 MEDIUM DUTY



0384-2571 BOX
0384-2572 CLAMSHELL

350 HEAVY DUTY



0384-2682 BOX
0384-2684 CLAMSHELL

OxyFuel 350 Heavy Duty Outfit

Specifications

Part No.	Description	Fuel Gas Type
0384-2682	OxyFuel 350 Heavy Duty Outfit (Box)	Acetylene
0384-2684	OxyFuel 350 Heavy Duty Outfit (Clamshell)	Acetylene



FEATURES

- High performance, complete system that meets or exceeds industry standards
- Superior 350 Series high flow color coded regulators
- Complete handle and cutting attachment optimized for multiple gases
- Up to 6" cutting capacity and 1/2" welding
- Flexible versatile platform
- Includes flashback arrestors
- Two year warranty

APPLICATIONS

The OxyFuel 350 Heavy Duty Outfit contains premium performance components for professional grade use. Optimized for 1" cut and 1/8" weld out of the box. Suitable for medium to heavy duty fusion welding, braze welding, brazing, heating and hand cutting applications.

CONTENTS

Oxygen/Acetylene 350 Series Regulators, 350 Series Cutting Attachment and Handle, Flashback Arrestors, Dual R-Grade Hose 12.5 ft., #1 Cutting Tip, #2 Welding Nozzle, Striker, Protective eyewear and Manual.

OxyFuel 250 Medium Duty Outfit

Specifications

Part No.	Description	Fuel Gas Type
0384-2571	OxyFuel 250 Medium Duty Outfit (Box)	Acetylene
0384-2572	OxyFuel 250 Medium Duty Outfit (Clamshell)	Acetylene



FEATURES

- High performance, complete system that meets or exceeds industry standards
- High performance 250 Series color coded regulators
- Complete handle and cutting attachment optimized for multiple gases
- Up to 5" cutting capacity and 1/2" welding
- Flexible versatile platform
- Two year warranty

APPLICATIONS

The OxyFuel 250 Medium Duty Outfit contains premium performance components for the value driven consumer. Optimized for 1/2" cut and 5/64" weld out of the box. Suitable for light to medium duty fusion welding, braze welding, brazing, heating and hand cutting applications.

CONTENTS

Oxygen/Acetylene 250 Series Regulators, 250 Series Cutting Attachment and Handle, Dual R-Grade Hose 12.5 ft., #0 Cutting Tip, #0 Welding Nozzle, Striker, Protective eyewear and Manual.

OxyFuel 250 Tote

Specifications

Part No.	Description	Fuel Gas Type
0384-0995	OxyFuel 250 Outfit, complete with carry tote and empty tanks*	Acetylene
0384-0996	OxyFuel 250 Outfit, complete with carry tote, no tanks*	Acetylene



FEATURES

- Complete portable system
- Cutting torch and handle are ready for multiple gas options; Oxy-Acetylene, Propane, Butane, Natural & LP Gases, & Propylene
- Simple to use rear-mount regulator with high contrast gauges
- Meets or exceeds industry safety standards
- Cut 1/8" (3.2 mm) to 3" (76.2 mm) steel
- Weld up to 1/4" (6.4 mm) Steel
- Constructed with high strength alloys, heavy duty stainless steel and durable brass
- Two year warranty

NOTE: TANKS ARE FOR EXCHANGE ONLY AND ARE EMPTY

APPLICATIONS

This OxyFuel 250 outfit complete with carry tote and empty tanks is the ideal entry level starter package. Optimized for 1/2" cut and 1/8" weld out of the box. Suitable for light duty fusion welding, braze welding, brazing and hand cutting applications.*

CONTENTS

Oxygen/Acetylene 150 Series Regulators, 250 Series Cutting Attachment and Handle, cylinder wrench with chain, Dual R-Grade Hose 12.5 ft., #0 Cutting Tip, #2 Welding Nozzle, Striker, Protective eyewear, Tote Carry Pak with storage and Manual. (with or without OX-20 cu. ft. Type "R" and AC-MC10 cu. ft. tanks depending on part no.)

*Not Recommended For Use With Heating Nozzles Due To Tank Size.

OxyFuel 250 Replacement Torch Kit

Specifications

Part No.	Description	Fuel Gas Type
0384-2573	OxyFuel 250 Torch Replacement Kit	All



*NOTE: For use with fuel gas other than Acetylene, proper tips, regulators or T-grade hoses may be required.

FEATURES

- Cutting torch and handle are ready for multiple gas options; Oxy-Acetylene, Propane, Butane, Natural & LP Gases, & Propylene
- Ergonomic color coded knobs (Acetylene & Oxygen)
- Meets or exceeds industry safety standards
- Cut 1/8" (3.2 mm) to 5" (127 mm) steel
- Heat using multiple heat nozzles
- Weld up to 1/2" (12.7 mm) steel
- Constructed with high strength alloys and heavy duty stainless steel and durable brass
- Two year warranty

APPLICATIONS

This OxyFuel 250 replacement torch kit delivers the latest generation of Victor® professional torch and handle design and operating platform.

CONTENTS

250 Series Cutting Attachment and Handle, #0 Cutting Tip, #0 Welding Nozzle, and Manual.

OXYFUEL REGULATORS

Acetylene, Oxygen & Argon CO₂

OxyFuel Acetylene Regulator

Specifications

Part No.	Description	Fuel Gas Type
0781-9827	OxyFuel 250 Acetylene Regulator, 510 CGA	Acetylene
0781-9830	OxyFuel 350 Acetylene Regulator, 510 CGA	Acetylene



FEATURES

- High performance single stage regulator with precise pressure and flow control
- Large clear gauges enable both inlet and delivery pressures to be read at a glance
- Clear color coding for the correct gas usage
- Forged brass body and high strength alloy bonnet
- Meets or exceeds industry standards
- 9/16" -18 outlet connection (LH)
- Two year warranty

APPLICATIONS

The OxyFuel 250 and 350 Acetylene regulators are suitable for a wide range of cutting, heating and welding applications using Acetylene fuel gas only.*

OxyFuel Oxygen Regulator

Specifications

Part No.	Description	Fuel Gas Type
0781-9826	OxyFuel 250 Oxygen Regulator, 540 CGA	Oxygen
0781-9829	OxyFuel 350 Oxygen Regulator, 540 CGA	Oxygen



FEATURES

- High performance single stage regulator with precise pressure and flow control
- Large clear gauges enable both inlet and delivery pressures to be read at a glance
- Clear color coding for the correct gas usage
- Forged brass body and high strength alloy bonnet
- Meets or exceeds industry standards
- 9/16" -18 outlet connection (RH)
- Two year warranty

APPLICATIONS

The OxyFuel 250 and 350 Oxygen regulators are suitable for a wide range of cutting, heating and welding applications using Oxygen gas only.

Argon/CO₂ Mixes Flowgauge Regulator

Specifications

Part No.	Description	Fuel Gas Type
0781-9832	Argon/CO ₂ Flowgauge Regulator, 580 CGA	Argon/CO ₂



FEATURES

- High performance single stage regulator with precise pressure and flow control
- Large clear gauges enable both inlet and delivery pressures to be read at a glance
- Clear color coding for the correct gas usage
- Forged brass body and high strength alloy bonnet
- Meets or exceeds industry standards
- 9/16" -18 outlet connection (RH)
- Two year warranty

APPLICATIONS

The Argon/CO₂ Flowgauge Regulator is suitable for MIG and TIG welding applications using Argon and Argon/CO₂ gas mixtures.

OxyFuel 150 Tote Regulators

Specifications

Part No.	Description	Fuel Gas Type
0781-8965	OxyFuel 150 Tote Acetylene Regulator, 200 CGA	Acetylene
0781-8966	OxyFuel 150 Tote Oxygen Regulator, 540 CGA	Oxygen



FEATURES

- High performance single stage regulator with precise pressure and flow control
- Large clear gauges enable both inlet and delivery pressures to be read at a glance
- Forged brass body and high strength alloy bonnet
- Meets or exceeds industry standards
- 9/16" -18 outlet connection (LH)
- Standard CGA, rear mount gas connections for Oxygen tote kits
- Two year warranty

APPLICATIONS

The Oxyfuel 150 Tote Regulators are suitable for a wide range of cutting, heating, and welding applications.

High Pressure Regulators

Specifications

Part No.	Description	Fuel Gas Type
0781-9726	1500 High Pressure Regulator, 580 CGA	Helium, Argon, Nitrogen
0781-9727	3000 High Pressure Regulator, 680 CGA	Helium, Argon, Nitrogen



FEATURES

- 0-4000 PSI cylinder gauge
- Max Inlet 3000
- 2-1/2" diameter gauges
- Brass construction, single stage regulator
- Two year warranty

APPLICATIONS

Heavy Duty, high pressure piston regulator.

Inert Regulator

Specifications

Part No.	Description	Fuel Gas Type
0781-9828	250 Inert Flow Regulator, 580 CGA	Inert



FEATURES

- High performance single stage regulator with precise pressure and flow control
- Large clear gauges enable both inlet and delivery pressures to be read at a glance
- Clear color coding for the correct gas usage
- Forged brass body and high strength alloy bonnet
- Meets or exceeds industry standards
- 9/16" -18 outlet connection (RH)
- Two year warranty

APPLICATIONS

The Inert Flowgauge Regulator is designed specifically for use with Nitrogen and Helium gases.

OxyFuel Cutting Attachments

Specifications

Part No.	Description	Fuel Gas Type
0381-0759	OxyFuel 250 Cutting Attachment	All
0381-0760	OxyFuel 350 Cutting Attachment	All

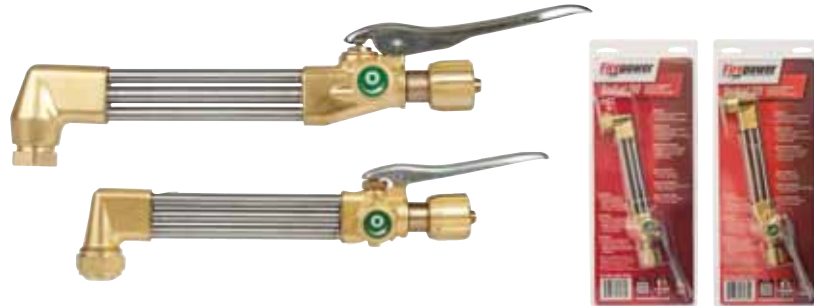

FEATURES

- Meets or exceeds Industry Standards
- Attaches quickly and easily to OxyFuel handle (no tools required)
- Cutting oxygen lever securely fitted to the body for ease of operation
- High strength triple stainless steel tube construction with good cutting visibility
- Multi gas operation: Oxy-Acetylene, Propane, Butane, Natural & LP Gases, & Propylene
- Cutting capacity up to 6" (350), up to 5" (250)
- Two year warranty

APPLICATIONS

Suitable for the following processes: hand cutting.

OxyFuel Cutting/Welding Handle

Specifications

Part No.	Description	Fuel Gas Type
0382-0358	OxyFuel 250-350 Torch Handle	All



NOTE: For use with Fuel Gas other than Acetylene. Proper Tips, Regulators or T-Grade Hoses may be required.



FEATURES

- Meets or exceeds Industry Standards
- High strength durable brass and alloy handle
- High precision valves for sensitive control for delicate welding jobs
- Easy light up for high flow heating applications
- Multi gas operation: Oxy-Acetylene, Propane, Butane, Natural & LP Gases, & Propylene
- Left and right hand threads prevent incorrect hose connection
- Color coded control knobs are fitted for maximum safety and ease of use, even when wearing gloves
- Two year warranty

APPLICATIONS

The OxyFuel Cutting and Welding Handle connects to Oxyfuel Cutting attachments and a complete line of Heating and Welding nozzles. Suitable for the following processes: Fusion welding, braze welding, brazing, soldering, heating, hand cutting.

OxyFuel Straight Cutting Torch

Specifications

Part No.	Description	Fuel Gas Type
0381-0751	350 OxyFuel ST900 Straight Cutting Torch	All



FEATURES

- Cutting torch and handle are ready for multiple gas options; Oxy-Acetylene, Propane, Butane, Natural & LP Gases, & Propylene
- Labeled knobs (Acetylene & Oxygen)
- Meets or exceeds industry safety standards
- Cut 1/8" (3.2 mm) to 6" (152.4 mm) steel
- Constructed with high strength alloys, heavy duty stainless steel and durable brass
- Two year warranty

APPLICATIONS

Suitable for the following processes: hand cutting.

OxyFuel Hoses

Specifications

Part No.	Description	Fuel Gas Type
1412-0012	3/16" x 12.5 ft. Dual R-Grade	Acetylene
1412-0020	3/16" x 25 ft. Dual R-Grade	Acetylene
1412-0021	1/4" x 25 ft. Dual R-Grade	Acetylene
1412-0022	1/4" x 50 ft. Dual R-Grade	Acetylene
1412-0081	3/16" x 12.5 ft. Dual T-Grade	All
1412-0185	3/16" x 25 ft. Dual T-Grade	All
1412-0189	1/4" x 25 ft. Dual T-Grade	All



FEATURES

- Premium quality hose that meets or exceeds the requirements of RMA and CGA
- Secure, specifically designed hose fittings ensure operator safety
- Color coded for easy identification
- Precut to length with fitted connections
- 12.5 ft., 25 ft. and 50 ft. lengths in 3/16" and 1/4" bore diameter
- R-Grade hose recommended for use with Acetylene

KEY INFORMATION

It is important to use the correct type of hose for the required gas(es) to be used. Any non-standard application should always be checked and approved before being put into operation.

Pressure drops will occur through hoses and hose fittings, therefore allowances must be made to compensate for this when setting up equipment and adjusting regulators.

Color coding of hoses and different threads for fuel and Oxygen prevents incorrect connections of hoses to the wrong gas type. Dual hoses help to keep the work area tidy, which reduces the risk of hose damage.



OxyFuel hoses are Grade "R" recommended for Oxygen and Acetylene, available in pre fitted lengths from 12.5 ft. to 50 ft. Compatible with all the OxyFuel range and suitable for light to heavy duty fusion welding, braze welding, brazing, heating and hand cutting applications.

OxyFuel Flashback Arrestors

Specifications

Part No.	Description	Fuel Gas Type
0656-0008	OxyFuel 250-350 FBT-2 Torch Flashback arrestors set with check valves	All
0656-0000	KC-1 Kwik Connect™ Pair Pak (Oxygen and Fuel)	All
0656-0016	OxyFuel 250-350 FPRA Regulator Flashback arrestor set with check valves	All



FEATURES

- Provide ultimate protection against "Flashback" and premature failure of system components
- High flow capacity
- Non-return valve
- Large cylindrical stainless steel flame arrestor

APPLICATIONS

Designed for connection to the inlet of the torch handle and used for all cutting, heating and welding applications.



OxyFuel Tanks & Totes

Specifications

Part No.	Description	Fuel Gas Type
0916-0033	OX-20 Type "R" Oxygen Cylinder, 20 cu. ft. Capacity*	Oxygen
0916-0032	AC-MC Type "MC" Acetylene Cylinder, 10 cu. ft. Capacity* ISO/DOT/TC	Acetylene
1421-0085	Cylinder Tote Only	All
0916-0028	NT-40 Nitrogen Cylinder, 40 cu. ft. (For Nitrogen Purging) ISO/DOT/TC	Nitrogen
0386-1226	TK Tank Key	-



FEATURES AC-MC*

- Type "MC" Acetylene Cylinder, 10 cu. ft. Capacity
- CGA 200 Connection
- DOT, TC Certified

FEATURES NT-40

- 40 cu. ft. Nitrogen Cylinder
- CGA 580 Connection
- DOT, TC Certified

FEATURES OX-20*

- Type "R" Oxygen Cylinder, 20 cu. ft. Capacity
- CGA 540 Connection
- DOT, TC Certified

APPLICATIONS

Tote and small tanks designed for smaller cutting and welding jobs allowing easy transport with this highly portable system.



*Not Recommended To Use Heating Nozzles With The 0916-0033 and 0916-0032 Tanks.

OxyFuel Cutting Tips

Refer to Table Below



ACETYLENE

NATURAL GAS

PROPYLENE



Type 101



Type GPN



Type GPP

*NOTE: For use with fuel gas other than Acetylene, proper tips, regulators or T-grade hoses may be required.

FEATURES

- Longer Nozzle life – high grade copper and advanced manufacturing techniques give the Firepower OxyFuel superior cutting life.
- Better quality cutting – the mirror smooth finish of the gas ports assures stable gas flow and superior cutting oxygen stream. Cuts are clean and smooth with the narrowest kerf.
- Less slag adhesion – copper content conducts heat away from the nozzle face. The nozzle keeps cooler and slag adherence to the nozzle face is reduced.
- Consistent manufacture batch testing ensures OxyFuel nozzles will consistently deliver the highest quality performance

APPLICATIONS

Used for cutting steel 1/8" to 6" thick.



- ACETYLENE TYPE CUTTING TIPS (TYPE 101)



TIP SIZE	PLATE THICKNESS	OXYFUEL 250 SERIES 3 - PART NO.	OXYFUEL 350 SERIES 1 - PART NO.	FUEL GAS FLOW (SCFH)	FUEL GAS PRESSURE (PSIG)	OXYGEN FLOW (TOTAL SCFH)	CUTTING OXYGEN PRESSURE (PSIG)
000	1/8" - 3 mm	6700-2438	6700-2408	3/5	3/5	20/25	20/25
00	1/4" - 6 mm	6700-2439	6700-2409	4/6	3/5	30/35	20/25
0	1/2" - 13 mm	6700-2440	6700-2410	6/10	3/5	60/65	30/35
1	3/4" - 19 mm	6700-2441	6700-2411	8/13	3/5	80/85	30/35
2	1" - 25 mm	6700-2442	6700-2412	10/16	3/6	140/150	35/40
3	2" - 51 mm	6700-2443	6700-2413	14/22	4/9	210/225	40/45
4	3" - 76 mm	6700-2444	6700-2414	18/30	5/10	270/320	40/50
5	5" - 127 mm	6700-2445	6700-2415	26/38	5/13	425/450	50/55
6	6" - 152 mm	-	6700-2416	30/44	7/13	500/600	45/40



- NATURAL GAS TYPE CUTTING TIPS (TYPE GPN)



*NOTE: To use these GPN tips, a T-grade hose and GPN regulators are required.

TIP SIZE	PLATE THICKNESS	OXYFUEL 250 SERIES 3 - PART NO.	OXYFUEL 350 SERIES 1 - PART NO.	FUEL GAS FLOW (SCFH)	FUEL GAS PRESSURE (PSIG)	OXYGEN FLOW (TOTAL SCFH)	CUTTING OXYGEN PRESSURE (PSIG)
000	1/8" - 3 mm	6700-2498	6700-2468	5/6	3/5	12/14	20/25
00	1/4" - 6 mm	6700-2499	6700-2469	5/7	3/5	22/26	20/25
0	1/2" - 13 mm	6700-2500	6700-2470	8/10	3/5	50/55	30/35
1	3/4" - 19 mm	6700-2501	6700-2471	10/12	4/6	70/80	30/35
2	1" - 25 mm	6700-2502	6700-2472	12/15	4/8	115/125	35/40
3	2" - 51 mm	6700-2503	6700-2473	14/18	5/9	150/175	40/45
4	3" - 76 mm	6700-2504	6700-2474	16/20	8/12	210/250	45/50
5	5" - 127 mm	6700-2505	6700-2475	20/30	8/12	330-360	50/55
6	6" - 152 mm	-	6700-2476	25/35	10/15	400/500	45/55



- PROPYLENE GAS TYPE CUTTING TIPS (TYPE GPP)



*NOTE: To use these GPP tips, a T-grade hose and GPP regulators are required.

TIP SIZE	PLATE THICKNESS	OXYFUEL 250 SERIES 3 - PART NO.	OXYFUEL 350 SERIES 1 - PART NO.	FUEL GAS FLOW (SCFH)	FUEL GAS PRESSURE (PSIG)	OXYGEN FLOW (TOTAL SCFH)	CUTTING OXYGEN PRESSURE (PSIG)
000	1/8" - 3 mm	6700-2618	6700-2588	5/6	3/5	12/14	20/25
00	1/4" - 6 mm	6700-2619	6700-2589	5/7	3/5	22/26	20/25
0	1/2" - 13 mm	6700-2620	6700-2590	8/10	3/5	50/55	30/35
1	3/4" - 19 mm	6700-2621	6700-2591	10/12	4/6	70/80	30/35
2	1" - 25 mm	6700-2622	6700-2592	12/15	4/8	115/125	35/40
3	2" - 51 mm	6700-2623	6700-2593	14/18	5/9	150/175	40/50
4	3" - 76 mm	6700-2624	6700-2594	16/20	8/12	210/250	45/50
5	5" - 127 mm	-	6700-2595	20/30	8/12	330/360	50/55
6	6" - 152 mm	-	6700-2596	25/35	10/15	400/500	45/55

OxyFuel Heating Nozzles

Specifications

Part No.	Description	Fuel Gas Type	Size	Oxygen Pressure (PSIG)	Acetylene Pressure (PSIG)	Oxygen Consumption (SCFH)	Acetylene Consumption (SCFH)
0387-0060	250-350 Series Multi-flame Nozzle (Clamshell)	Acetylene	4	8/12	6/10	7/22	6/20
0324-0143	150 Series Multi-flame Nozzle (Clamshell)	Acetylene	4	8/12	6/10	7/22	6/20
0387-0061	250-350 Series Multi-flame Nozzle (Clamshell)	Acetylene	6	10/15	8/12	15/44	14/40
0324-0146	150 Series Multi-flame Nozzle (Clamshell)	Acetylene	6	10/15	8/12	15/44	14/40
0387-0062	250-350 Series Multi-flame Nozzle (Clamshell)	Acetylene	8	20/30	10/15	33/88	30/80
0324-0112	150 Series Multi-flame Nozzle (Clamshell)	Acetylene	8	20/30	10/15	33/88	30/80



FEATURES

- Concentrated high temperature flame
- Wide range for different applications
- Connects directly to the OxyFuel torch handle platform*

APPLICATIONS

Used for concentrated heating of steel and other materials.

*Heating Nozzles Are Not Recommended For Use With Tote Outfits, 0916-0032 and 0916-0033 Tanks.



OxyFuel Welding Nozzles

Specifications

Part No.	Description	Fuel Gas Type	Metal Inches	Thickness Mm	Drill Size	Oxygen (PSIG)	Acetylene (PSIG)	Acetylene (SCFH)
0323-0360	#0 Acetylene Welding Nozzle	Acetylene	5/64"	1.9	65 (0.035)	3/5	3/5	2/4
0324-0150	#0 Acetylene 150 Welding Nozzle	Acetylene	5/64"	1.9	65 (0.035)	3/5	3/5	2/4
0323-0361	#1 Acetylene Welding Nozzle	Acetylene	3/32"	2.4	60 (0.040)	3/5	3/5	3/6
0324-0151	#1 Acetylene 150 Welding Nozzle	Acetylene	3/32"	2.4	60 (0.040)	3/5	3/5	3/6
0323-0362	#2 Acetylene Welding Nozzle	Acetylene	1/8"	3.2	56 (0.046)	3/5	3/5	5/10
0324-0152	#2 Acetylene 150 Welding Nozzle	Acetylene	1/8"	3.2	56 (0.046)	3/5	3/5	5/10
0323-0363	#3 Acetylene Welding Nozzle	Acetylene	1/16"	4.8	53 (0.060)	4/7	3/6	8/18
0324-0153	#3 Acetylene 150 Welding Nozzle	Acetylene	1/16"	4.8	53 (0.060)	4/7	3/6	8/18
0323-0364	#4 Acetylene Welding Nozzle	Acetylene	1/4"	6.4	49 (0.073)	5/10	4/7	10/25
0324-0154	#4 Acetylene 150 Welding Nozzle	Acetylene	1/4"	6.4	49 (0.073)	5/10	4/7	10/25
0323-0365	#5 Acetylene Welding Nozzle	Acetylene	1/2"	12.7	43 (0.089)	6/12	5/8	15/35
0324-0155	#5 Acetylene 150 Welding Nozzle	Acetylene	1/2"	12.7	43 (0.089)	6/12	5/8	15/35



FEATURES

- Concentrated high temperature flame
- Wide range for different applications
- Connects directly to the OxyFuel torch handle platform

APPLICATIONS

Used for fusion welding, braze welding, brazing, and soldering of thin steel and other weldable materials.

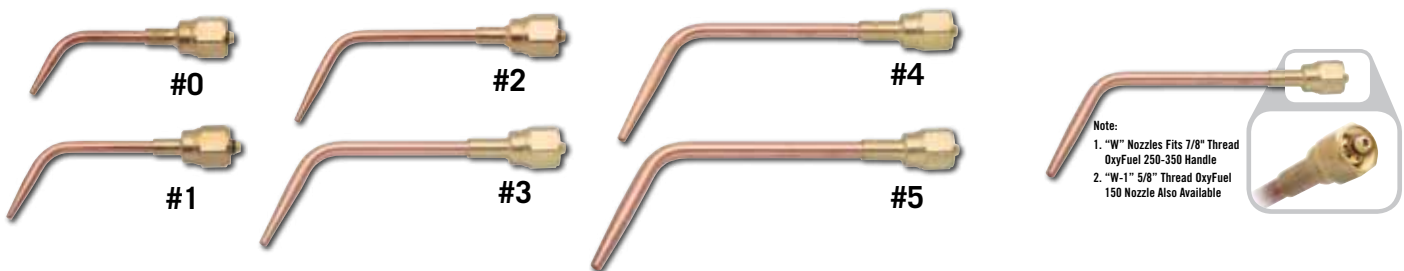

OxyFuel Welding Rods

Specifications

Part No.	Description	Dimensions	Weight
1440-0442	Oxygen/Acetylene Mild Steel (Copper Coated)	1/16" x 18"	5 lbs.
1440-0427	MANGANESE Bronze Bare Gas Rods	3/32" x 36"	5 lbs.
1440-0428	MANGANESE Bronze Bare Gas Rods	1/8" x 36"	5 lbs.
1440-0431	MANGANESE Bronze Flux Coated Gas Rods	3/32" x 36"	1 lb.
1440-0429	MANGANESE Bronze Flux Coated Gas Rods	3/32" x 36"	5 lbs.
1440-0430	MANGANESE Bronze Flux Coated Gas Rods	1/8" x 36"	5 lbs.

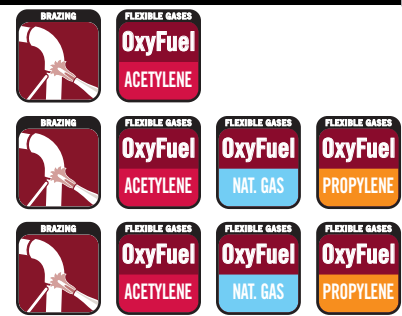

Adapters

Specifications

Part No.	Description	Fuel Gas Type
0387-0490	FP Adapter CGA 300Tank/510Reg.	ALL
0387-0492	FP Adapter CGA 510Tank/300Reg.	ALL
0387-0488	FP Adapter CGA 510Tank/520Reg.	ALL
0387-0491	FP Adapter CGA 520Tank/200Reg.	ALL
0387-0489	FP Adapter CGA 520Tank/510Reg.	ALL



FEATURES

- Adapts different sized cylinders to the regulator
- Forged brass body

APPLICATIONS

FP Adapter CGA 300Tank/510Reg. - Allows the connection between a CGA 300 Tank to a 510 Regulator.
 FP Adapter CGA 510Tank/300Reg. - Allows the connection between a CGA 510 Tank to a 300 Regulator.
 FP Adapter CGA 510Tank/520Reg. - Allows the connection between a CGA 510 Tank to a 520 Regulator.
 FP Adapter CGA 520Tank/200Reg. - Allows the connection between a CGA 520 Tank to a 200 Regulator.
 FP Adapter CGA 520Tank/510Reg. - Allows the connection between a CGA 520 Tank to a 510 Regulator.

AirFuel Tanks

Specifications

Part No.	Description	Fuel Gas Type
0387-0436	Firepower FP 1 lb. Propane Tank	Propane
0916-0122	MAP//Pro™, 600 CGA	MAP//Pro



FEATURES

- Contains 14.1 oz. propane

APPLICATIONS

Replacement tank for use with all Firepower hand torches.

Welding Flow Gauge

Specifications

Part No.	Description	Fuel Gas Type
0781-2733	HRF 1480-580FPH clamshell, with hose, 580 CGA	Argon/CO ₂



FEATURES

- Maximum inlet pressure 3,000 PSIG, outlet pressure is present for 80 PSIG
- Flow range is 10-50/Argon gas, 580 CGA male threaded connection
- Model includes 10" gas hose
- Easy to read flow tube for accurate adjustments
- Specifically designed for MIG, TIG and other inert gas welding applications
- Two year warranty

APPLICATIONS

The Flowmeter Regulator is used with most MIG or TIG welding applications.

GAS EQUIPMENT

Protective Eyewear

Specifications

Part No.	Description	FEATURES	ANSI Z87.1	SAFETY
1423-4182	Clear Protective Eyewear 	<ul style="list-style-type: none"> ■ Rubber arm tips assure comfort and non-slip use; Ultra-light frames allow comfortable protection and long hours of wearability ■ Hard-coated polycarbonate lens ■ Tilting arms allow improved spark and debris protection above and below eyes; Contoured frame and built-in nose bridge fits any shape of face ■ Complies with ANSI Z87.1 and CSA Z94.3 standards 	STANDARD ANSI Z87.1	SAFETY C SP US
1423-0020	Clear Safety Goggle, with Clear Lens 	<ul style="list-style-type: none"> ■ Furnished with tough polycarbonate clear lens ■ For protection against flying particles and dust ■ Soft vinyl frame fits snugly and can be worn for extended periods with comfort ■ Transparent frame allows vision in all directions ■ Hooded vents prevent fogging and offers excellent ventilation ■ Adjustable elastic headband ■ Meets or exceeds ANSI Z87.1 and various International Standards 	STANDARD ANSI Z87.1	
1441-3408	Symetrix – Wrap-a-Round Visitor Glasses 	<ul style="list-style-type: none"> ■ Meets or exceeds ANSI Z87.1 and various International Standards 	STANDARD ANSI Z87.1	
1423-4181	Shade 5 Protective Eyewear 	<ul style="list-style-type: none"> ■ Rubber arm tips assure comfort and non-slip use; Ultra-light frames allow comfortable protection and long hours of wearability ■ Hard-coated polycarbonate lens; Eliminates 99.9% of ultraviolet light ■ Tilting arms allow improved spark and debris protection above and below eyes; Contoured frame and built-in nose bridge fits any shape of face ■ Complies with ANSI Z87.1 and CSA Z94.3 standards 	SHADE #5	STANDARD ANSI Z87.1 SAFETY C SP US
1423-4177	Luxur – Fashion Safety Glasses, One-piece Lens, Adjustable Templates 	<ul style="list-style-type: none"> ■ Meets or exceeds ANSI Z87.1 and various International Standards 	SHADE #5	STANDARD ANSI Z87.1
1423-0017	Fixed Front, Welder's Goggle Soft Frame 	<ul style="list-style-type: none"> ■ Furnished with filter lens (Shade 5) ■ Soft vinyl frame fits easily over corrective glasses ■ Hooded vents prevent fogging and offers excellent ventilation ■ Adjustable elastic headband ■ Meets or exceeds ANSI Z87.1 and various International Standards 	SHADE #5	STANDARD ANSI Z87.1 SAFETY C SP US STANDARD CE
1423-0018	Lift Front, Welder's Goggle Soft Frame 	<ul style="list-style-type: none"> ■ Filter lens frame raises easily for on-the-job versatility (Lift Front Type) ■ Furnished with filter lens (Shade 5) ■ Soft vinyl frame fits easily over corrective glasses ■ Hooded vents prevent fogging and offers excellent ventilation ■ Adjustable elastic headband ■ Meets or exceeds ANSI Z87.1 and various International Standards 	SHADE #5	STANDARD ANSI Z87.1 STANDARD CE
1423-0019	Cup-Type Goggle, 50 mm 	<ul style="list-style-type: none"> ■ Hard Plastic ■ Comes with tough polycarbonate lens (Shade 5) ■ Adjustable elastic headband and nose piece ■ Meets or exceeds ANSI Z87.1 and various International Standards 	SHADE #5	STANDARD ANSI Z87.1 SAFETY C SP US STANDARD CE

AirFuel Pencil Tip Torch & Kit

Specifications

Part No.	Description	Fuel Gas Type
0387-0470	Firepower P-10 Pencil Tip Propane Torch	Propane
0387-0471	Firepower FP PK-10 Pencil Tip Propane	Propane



FEATURES

- For use with 14.1 oz. or 16 oz.
- Solid Brass burn tube construction.
- Two year warranty

APPLICATIONS

The Manual Light Propane Pencil Tip Torch is suitable for Brazing, Heating and Soldering.

AirFuel Hand Torch Kit

Specifications

Part No.	Description	Fuel Gas Type
0387-0400	Firepower AirFuel Manual Light Hand Torch	Propane, MAP//PRO™



FEATURES

- Silver solder copper tubing or Bronze braze steel pip
- Swirl combustion tip maximizes heat and reduces brazing time by 30%. 360
- For 14.1 oz. or 16 oz. disposable Propane or MAP//Pro
- Two year warranty

APPLICATIONS

The Manual Light Hand Torch is suitable for Brazing, Heating and Soldering.

AirFuel Vers-A-Flame Torch Kits

Specifications

Part No.	Description	Fuel Gas Type
0384-1280	Firepower Vers-A-Flame 350K BTU 1 Ea	Propane
0384-1260	Firepower Vers-A-Flame 500K BTU 1 Ea	Propane



FEATURES

- Durable Brass Control Knob
- Tough 10' Hose
- Meets or exceeds Industry Safety Standards
- For use with L.P. Tanks 20 lbs. or Larger
- Two year warranty

APPLICATIONS

The Vers-A-Flame is suitable for a wide range of uses.
Auto/Farm & Home use: Burns weeds, removes paint and melts ice.
Construction uses: Preheat asphalt & tar, remove road markings and reheat large castings for welding.

GAS EQUIPMENT

AirFuel Hand Torch

Specifications

Part No.	Description	Fuel Gas Type
0387-0463	Firepower AirFuel SMP-31 Hand Torch	Propane, MAP//Pro



FEATURES

- Auto Igniter for Instant Flame
- Trigger lock on button
- For 14.1 oz. or 16 oz. disposable Propane or MAP//Pro
- Two year warranty

APPLICATIONS

The Auto Igniting Hand Torch is suitable for Brazing, Heating and Soldering.

AirFuel Torch Kit

Specifications

Part No.	Description	Fuel Gas Type
0387-0464	Firepower AirFuel SMPK-31 Torch Kit	Propane, MAP//Pro



FEATURES

- Auto Igniter for Instant Flame
- Trigger lock on button
- For 14.1 oz. or 16 oz. disposable Propane or MAP//Pro
- Two year warranty

APPLICATIONS

The Auto Igniting Hand Torch is suitable for Brazing, Heating and Soldering.

AirFuel Hand Torch

Specifications

Part No.	Description	Fuel Gas Type
0387-0465	Firepower AirFuel SMP-41 Hand Torch	Propane, MAP//Pro



FEATURES

- Auto Igniter for Instant Flame
- Trigger lock on button
- For 14.1 oz. or 16 oz. disposable Propane or MAP//Pro
- Two year warranty

APPLICATIONS

The Auto Igniting Hand Torch is suitable for Brazing, Heating and Soldering.



Manual Plasma

AirCut™ 15C Part No. 1-1110-1 **Available in USA only*
Portable Plasma Cutting System with Built-In Air Compressor

Internal Air Compressor. This unit comes standard with a built-in air compressor.

Lightweight. Weighs only 29 lbs. (13.2kg), almost 50% lighter than the competition.

Superior Cutting Capacity. 1/8" (3mm) Recommended Cut, 3/16" (5mm) maximum capability.

Easy to Use. 120V, 15 Amp plug standard. Plug it in anywhere!

Faster Cut Speeds. 25% more cutting power provides 25% faster cut speeds than the competition.

Specifications

- Cut Capacity:** 1/8" (3mm) Recommended Cut
- Output Current:** 15 Amps Fixed
- Input Power:** 120V (± 10%), Single Phase, 60Hz., 12 Amps
- Duty Cycle:** 35% @ 15A
- Dimensions:** Length 18" (457mm)
Width 6.5" (165mm)
Height 9.5" (241mm)
- Weight:** 29 lbs. (13.2 kg)
- Ship Weight:** 38 lbs. (17.2 kg)
(includes Unit, Power Cable, Torch and Leads)
- Work Cable:** 19.5 ft. (5.9m)
- Input Cable:** 8.5 ft. (2.6m)
- Gas Type:** Air from Built-In Air Compressor
- Pilot:** CD Start
- Control:** Hand Torch Switch
- Torch:** PCH-10
- Torch Configuration:** Hand 70°, 20' (6.1m) Leads



MANUAL PLASMA

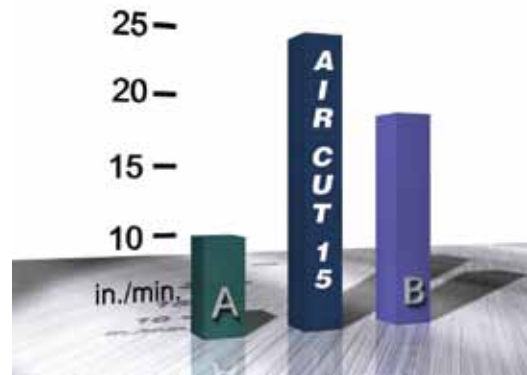

Cut Speed Comparison 1/8" (3mm)

Cutmaster® 42 Part No. 1-4200

The Thermal Dynamics® TRUE™ Series Cutmaster 42 is one of the most affordable, highest quality 1/4" (6 mm) plasma systems on the market. As part of the TRUE Series, you can rely on the Cutmaster 42 to cut all day at its recommended cutting capacity and to pack more punch when you need it.

The Cutmaster 42 incorporates Vent2Shield™ technology allowing the use of a considerably smaller compressor (less weight to carry, can be used with 120V) compared to similar 40A units.

Applications include:

- Auto Body/Marine Repair
- Plumbing & HVAC
- Home Shop
- Metal Building & Roofing Construction
- Rental Fleets



FOUR YEAR **4** WARRANTY

VENT **2** SHIELD TECHNOLOGY

Max Amperage Output - (Amps)	27 @ 120V 40 @ 230V
Output Power - (Kw)	3.8
Recommended Cut - Inches (mm)	1/4" (6)
Max Cut - Inches (mm)	5/8" (15)
Pierce Rating - Inches (mm)	1/4" (6)
Input Voltage - (Volts, Phase, Hz)	120-230V, 1 Phase, 50/60Hz
Duty Cycle (@40°C)	40% @ 40A @ 230V
Amperage Draw	29A @ 120V 15A @ 230V
Dimensions (H x W x L) Inches (mm)	9 x 7 x 18.5 (228 x 117 x 470)
Weight - lbs (kg)	26 (11.8)
Torch Model	SL40™
Air Pressure - psi (bar)	75 (5.2)
Flow - Cfm (l/m)	3.2 (91)
Warranty (Unit/Torch) Parts and Labor	4/1

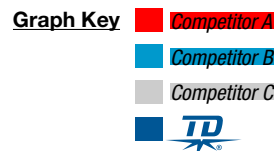
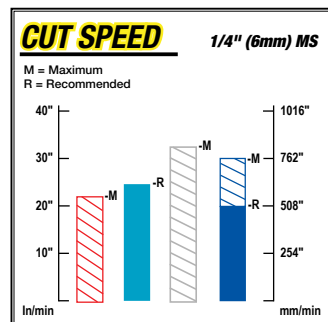
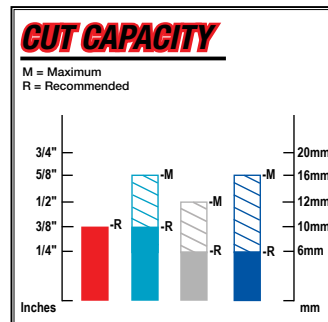

CUTMASTER TRUE SERIES

42

RECOMMENDED CUT
1/4"

MAXIMUM CUT
5/8"

150%
MORE PUNCH
WHEN YOU NEED IT.

MANUAL PLASMA

Cutmaster® 52 Part No. 1-5130-1

The Cutmaster 52 is the most powerful and lightest weight 1/2" (12mm) machine on the market today. The Cutmaster TRUE™ Series are the only systems that offer the precision of the TRUE Cut Drag Tip Series. The 60 Amp tip allows the system to drag cut up to 1/4" (6mm) with ease. Giving the absolute best cut quality possible.

This unit cuts through mild, stainless, or aluminum up to 1.125" (30mm) thick. The Cutmaster 52 combines power with the well known performance and features of the industry-leading 1Torch®.

Applications include:

- Construction
- Maintenance/Repair
- Fabrication



MANUAL PLASMA

FOUR YEAR **4** WARRANTY

CUTMASTER TRUE SERIES

52

RECOMMENDED CUT

1/2"

MAXIMUM CUT

1 1/8"

125% MORE PUNCH

WHEN YOU NEED IT.

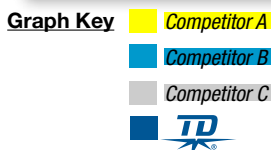
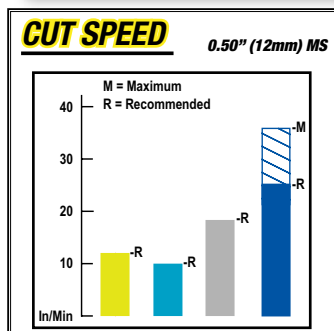
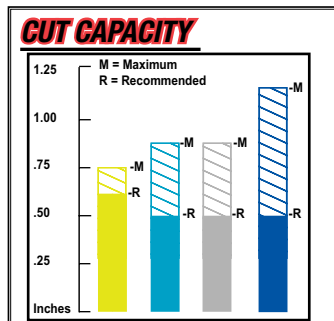

Max Amperage Output - (Amps)	60
Output Power - (Kw)	6.2
Recommended Cut - Inches (mm)	0.500 (12)
Max Cut - Inches (mm)	1.125 (30)
Pierce Rating - Inches (mm)	0.500 (12)
Input Voltage - (Volts, Phase, Hz)	<ul style="list-style-type: none"> • 208/230 - 460 1/3 Phase 50/60Hz • 400V 3 Phase 50Hz • 600V 3 Phase 50/60Hz
Duty Cycle (@40°C)	40% @ 60A, 60% @ 55A, 100% @ 50A
Amperage Draw	<ul style="list-style-type: none"> 45 (230V, 1 ph) 24 (230V, 3 ph) 16 (460V, 3 ph)
Dimensions (H x W x L) Inches (mm)	15 x 12 x 24 (381 x 305 x 610)
Weight - lbs (kg)	43 (19.5)
Torch Model	SL60 Hand SL100 Mechanized
Air Pressure - psi (bar)	75 (5.2)
Flow - Cfm (l/m)	6.7 (190)
Warranty (Unit/Torch) Parts and Labor	4/1

Cutmaster® 82 Part No. 1-1130-1

The Cutmaster 82 weighs in at a mere 43 lbs. (19.5kg) almost 50% less than its leading competitor, while still offering superior cutting power.

Don't let the size of this unit fool you, it's more than capable of cutting 3/4" (20mm) with a maximum capability of 1 1/2" (40mm). This unit, like all other TRUE™ Cutmasters, is equipped with the 1Torch®.

Applications include:

- Heavy Fabrication
- Manufacturing
- Contractors



MANUAL PLASMA

FOUR YEAR **4** **WARRANTY**

Max Amperage Output - (Amps)	80
Output Power - (Kw)	9
Recommended Cut - Inches (mm)	0.750 (20)
Max Cut - Inches (mm)	1.500 (40)
Pierce Rating - Inches (mm)	0.625 (15)
Input Voltage - (Volts, Phase, Hz)	<ul style="list-style-type: none"> • 208/230 - 460 • 1/3 Phase 50/60Hz • 400V 3 Phase 50Hz • 600V 3 Phase 50/60Hz
Duty Cycle (@40°C)	40% @ 80A, 60% @ 65A 100% @ 55A
Amperage Draw	72 (230V, 1 ph) 39 (230V, 3 ph) 21 (460V, 3 ph)
Dimensions (H x W x L) Inches (mm)	15 x 12 x 24 (381 x 305 x 610)
Weight - lbs (kg)	43 (19.5)
Torch Model	SL60 Hand SL100 Mech & Auto
Air Pressure - psi (bar)	70 (4.8)
Flow - Cfm (l/m)	6.7 (190)
Warranty (Unit/Torch) Parts and Labor	4/1

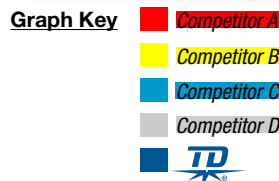
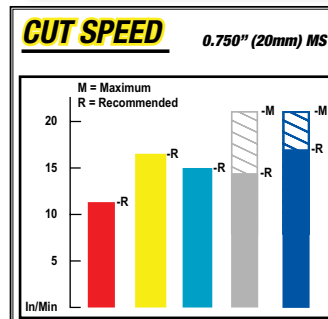
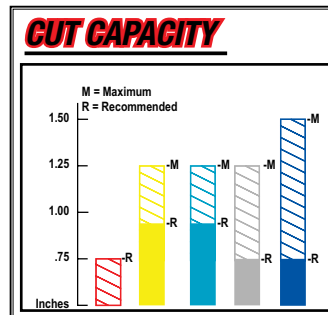

CUTMASTER TRUE SERIES

82

RECOMMENDED CUT

3/4"

MAXIMUM CUT

1 1/2"

100% MORE PUNCH WHEN YOU NEED IT.

CutSkill® C-20A Part No. 1-1625 **Available in USA only*

Fast, Easy Cuts on Most Metals. A favorite for HVAC installations, sheet metal fabrication, metal art, and home projects, this machine delivers clean cuts on most metals including stainless steel, aluminum, mild steel copper or brass, with minimum heat input & distortion of metal. It also cuts through rusted, painted or coated surfaces without prior surface preparation.

Portable and Powerful. This inverter based power supply automatically links the unit to primary voltage from 115 to 230 Volts, single phase, 50 or 60 Hz, typically found in most homes and maintenance shops. Weighing just 44 lbs. (20 kg), the C-20A is easy to move from location to location. Connect to an air compressor, and this simple-to-use system is ready to cut.

More Torch, Less Money. The SL60™ 1Torch® provides state-of-the-art technology and the performance you would expect with a higher priced torch. Compare these important features:

- Precision-engineered consumable parts are easy to change and require no tools
- Easy-to-use torch trigger release and ergonomic handle provide comfort during long cutting sessions
- Latch feature allows the cutting arc to remain active without constantly depressing the torch switch
- Starts without high-frequency so it won't interfere with controls or computers
- SureLok® electrode eliminates tip wobble found in some blow-apart torch designs, resulting in a cleaner arc and longer parts life
- Protective interlock circuitry disables the power supply if torch consumable parts are incorrectly assembled
- Light-weight, flexible 20 ft. (6.1m) torch leads
- Full 1-year warranty on repair parts and labor



MANUAL PLASMA

Cut Capacity	Input	Output	Duty Cycle	Panel Indicators	Dimensions	Weight
3/8" (10mm)	115V +/-10%, 1 ph, 50/60 Hz, 20A 230V +/-10%, 1 ph, 50/60 Hz, 14A	20A @ 115VAC 25A @ 230VAC	30% @ 20 Amps	AC, Over Temp, Air, Latch	H: 14.8" (375mm) W: 8.3" (210mm) L: 20.0" (510mm)	Net: 44 lbs. (20 kg) Ship: 53 lbs. (24 kg)

CutSkill® C-35A Part No. 1-1635-1 **Available in USA only*

Clean Cuts with Little or No Dross. Designed for the 1/2" (12mm) cutting market, this economical plasma cutter is a favorite for auto body repair, light duty maintenance, and sheet metal fabrication, and it is also very useful around the farm or ranch. It cuts quickly through stainless steel, aluminum, mild steel copper or brass, with minimum heat input & distortion of metal and it also cuts through rusted, painted or coated surfaces without prior surface preparation.

Portable and Powerful. This inverter-based system operates on standard 230 VAC single phase input power and provides adjustable current from 15 to 35 amps. Weighing just 44 lbs. (20 kg), this lightweight power source is easy to move from location to location. Simply connect to an air compressor or other air source and you are ready to cut.



See What You Cut . . . While You Cut. Precise, reliable cutting is what you can expect from the SL60® 1Torch®, and the excellent front end parts visibility lets you see what you cut, while you cut. Important features & benefits include:

- Precision-engineered consumable parts are easy to change and require no tools
- Easy-to-use torch trigger release and ergonomic handle provide comfort during long cutting sessions
- Two modes of operation available – standoff cutting or drag cutting
- Light-weight, flexible 20 ft. (6.1m) torch leads
- Latch feature allows the cutting arc to remain active without constantly depressing the torch switch
- Starts without high-frequency so it won't interfere with controls or computers
- SureLok® electrode eliminates tip wobble found in some blow-apart torch designs, resulting in a cleaner arc and longer parts life
- Protective interlock circuitry disables the power supply if torch consumable parts are incorrectly assembled
- Full 1-year warranty on repair parts and labor

Cut Capacity	Input	Output	Duty Cycle	Panel Indicators	Dimensions	Weight
1/2" (12mm)	230V +/-10%, 1 ph, 50/60 Hz, 32A	15-35 Amps, Continuously Adjustable	35% @ 35 Amps	AC, Over Temp, Air, Latch	H: 14.8" (375mm) W: 8.3" (210mm) L: 20.0" (510mm)	Net: 44 lbs. (20 kg) Ship: 53 lbs. (24 kg)

CutSkill® C-70A Part No. 1-1670-1 *Available in USA only

Great for Fabrication or Scrapping. A favorite for use in heavy maintenance, fabrication and scrap metal, this machine delivers clean cuts on most 1" (25mm) metals including stainless steel, aluminum, mild steel, copper or brass, with minimum heat input & distortion of metal. It also cuts through rusted, painted or coated surfaces without prior surface preparation.

Reliable, Powerful Power Supply. This inverter based power supply operates on standard 230 Volt, single or 3-phase power. (CE model only available at 3 ph.) Simply connect to an air compressor or other air source, and this system is ready to cut.

1Torch® for Excellent Cutting Results. This state-of-the-art torch provides the level of performance and features you would expect from a more expensive torch. Compare these important features:

- Precision-engineered consumable parts are easy to change and require no tools.
- Easy-to-use torch trigger release and ergonomic handle provide comfort during long cutting sessions
- Two modes of operation available – standoff cutting or drag cutting
- Latch feature allows the cutting arc to remain active without constantly depressing the torch switch
- Starts without high-frequency so it won't interfere with controls or computers
 - Protective interlock circuitry disables the power supply if torch consumable parts are incorrectly assembled
 - SureLok® electrode eliminates tip wobble found in some blow-apart torch designs, resulting in a cleaner arc and longer parts life
 - Light-weight, flexible 20 ft. (6.1m) torch leads
- Full 1-year warranty on repair parts and labor



MANUAL PLASMA

Cut Capacity	Input	Output	Duty Cycle	Panel Indicators	Dimensions	Weight
1" (25mm)	230V +/-10%, 1 ph, 50/60 Hz, 67A 230V +/-10%, 1 ph, 50/60 Hz, 37A 400V +/-10%, 3 ph, 50/60 Hz, 23A 400V +/-10%, CE, 3 ph, 50/60 Hz, 23A	25-70 Amps, Continuously Adjustable	35% @ 70 Amps	AC, Over Temp, Air, Latch	H: 16.5" (420mm) W: 9.7" (245mm) L: 21.7" (550mm)	Net: 66 lbs. (30 kg) Ship: 75 lbs. (34 kg)

AirCut™ 15C Parts and Accessories

Accessories

	Part No.
PCH-10 70° Torch / 20' (6.1m) Leads	2-1020
Cutting Guide Kit	7-8910
20 ft. (6.1m) Leather Leads Cover	9-1260
Shield Cup	9-6003
Tip	9-6099
Gas Distributor	9-6007
Electrode	9-6006



Multi-Purpose Cart Part No. 7-8888

Designed for most portable manual cutting systems such as the Cutmaster® 39, 52, 82 or any other similar sized systems.

This rugged steel cart has easy rolling 8" (203mm) diameter wheels along with 3" (76mm) front mounted casters. This cart also serves as an excellent showroom display stand.



CUTMASTER® 42 / 52 / 82 Parts and Accessories



Current Range	Mode Of Operation	Amps	Electrode	Start Cartridge	Tip	Shield Cup	Shield Cup Body	Drag Shield Cap	Deflector	Gouging Shield Cap		
SL40™ Consumables (for use with Cutmaster® 42)												
10-40 Amps	Standoff Cutting	40A	9-0096	9-0097	9-0094	9-0098						
	Drag Tip / Cutting	20A			9-0091							
	Drag Tip / Cutting	40A			9-0093							
SL60® and SL100® Consumables												
20-40 Amps	Drag Tip / Cutting	20A	9-8215	9-8213	9-8205	9-8218						
		30A			9-8206	9-8218						
		40A			9-8207	9-8218						
		20A			9-8205	9-8237					9-8243	
		30A			9-8206	9-8237					9-8243	
		40A			9-8207	9-8237					9-8243	
	Standoff Cutting	40A			9-8208	9-8218					9-8241	
		40A			9-8208	9-8237					9-8243	
	Gouging	Tip A			9-8225	9-8237						
50-60 Amps	Drag Tip / Cutting	60A	9-8215	9-8213	9-8252	9-8218						
		50-55A			9-8209	9-8218						
	Standoff Cutting	60A			9-8210	9-8218						
		50-55A			9-8209	9-8237						9-8243
		60A			9-8210	9-8237						9-8243
	Drag Shield Cutting	50-55A			9-8209	9-8237	9-8235					
		60A			9-8210	9-8237	9-8235					
	Gouging	Tip B			9-8226	9-8237						9-8241
		Tip C			9-8227	9-8237						9-8241
		Tip D			9-8228	9-8237						9-8241
70-100 Amps	Standoff Cutting	70A	9-8215	9-8213	9-8231	9-8218						
		80A			9-8211	9-8218						
		90-100A			9-8212	9-8218						
		70A			9-8231	9-8237					9-8243	
		80A			9-8211	9-8237					9-8243	
		90-100A			9-8212	9-8237					9-8243	
	Drag Shield Cutting	70A			9-8231	9-8237	9-8236					
		80A			9-8211	9-8237	9-8236					
		90-100A			9-8212	9-8237	9-8236					
	Gouging	Tip B			9-8226	9-8237						9-8241
		Tip C			9-8227	9-8237						9-8241
		Tip D			9-8228	9-8237						9-8241
120 Amps	Standoff Cutting	120A	9-8215	9-8213	9-8253		9-8237	9-8258	9-8243			
	Drag Shield Cutting	120A			9-8253	9-8237	9-8258	9-8243				
	Gouging	Tip E			9-8254	9-8237		9-8243	9-8241			

MANUAL PLASMA

CutSkill® C-20A Parts and Accessories

Accessories	Part No.
TORCH	
SL60, 20 ft. (6.1m) Leads	7-5200
Shield Cup	9-8218
Tip (pkg. of 5)	9-8206
Start Cartridge	9-8213
Electrode (pkg. of 5)	9-8215
O-Ring	8-3487
O-Ring	8-3486

Accessories	Part No.
Cutting Guide Kit	7-8910
Single Stage Air Filter	7-7507
20 ft. (6.1m) Leather Leads Cover	9-1260



Single Stage Air Filter
Part No. 7-7507



Cutting Guide Kit
Part No. 7-8910



Leather Leads Cover
Part No. 9-1260

CutSkill C-35A Parts and Accessories

Accessories	Part No.
TORCH	
SL60, 20 ft. (6.1m) Leads	7-5200
Shield Cup	9-8218
Tip - 40A (pkg. of 5)	9-8207
Start Cartridge	9-8213
Electrode (pkg. of 5)	9-8215
O-Ring	8-3487
O-Ring	8-3486

Accessories	Part No.
Cutting Guide Kit	7-7501
Single Stage Air Filter	7-7507
20 ft. (6.1m) Leather Leads Cover	9-1260
Standoff Guide	9-8251



Standoff Guide
Part No. 9-8251



Single Stage Air Filter
Part No. 7-7507



Cutting Guide Kit
Part No. 7-7501



Leather Leads Cover
Part No. 9-1260

CutSkill C-70A Parts and Accessories

Accessories	Part No.
TORCH	
SL100, 20 ft. (6.1m) Leads	7-5202
Shield Cup	9-8218
Tip - 70A (pkg. of 5)	9-8231
Start Cartridge	9-8213
Electrode (pkg. of 5)	9-8215
O-Ring	8-3487
O-Ring	8-3486

Accessories	Part No.
Cutting Guide Kit	7-7501
Single Stage Air Filter	7-7507
20 ft. (6.1m) Leather Leads Cover	9-1260
Standoff Guide	9-8281



Standoff Guide
Part No. 9-8281



Single Stage Air Filter
Part No. 7-7507



Cutting Guide Kit
Part No. 7-7501



Leather Leads Cover
Part No. 9-1260



Arc Welding

MIG/FLUX CORED WELDERS

Tweco Fabricator 141i



Fabricator® 141i Part No. W1003141 3-in-1 Welding System

ARC WELDING

Machine Specifications

Maximum output	140 Amp
MIG (GMAW/FCAW) Welding	140A / 19V @ 15% Duty Cycle
Output @104°F (40°C)	90A / 18.5V @ 20% Duty Cycle
STICK (SMAW) Welding	90A / 23V @ 15% Duty Cycle
Output @104°F (40°C)	80A / 23.2V @ 35% Duty Cycle
TIG (GMAW) Welding	140A / 15.6V @ 15% Duty Cycle
Output @104°F (40°C)	100A / 14V @ 20% Duty Cycle
Current range	10A - 140 Amp
MIG Welding Voltage Range	14.5V - 19V
Wire Diameter Range	Solid: .023" - .030" (0.6 - 0.8 mm)
	Stainless steel: .023" - .030" (0.6 - 0.8 mm)
	Flux cored: .030" - .035" (0.8 - 0.9 mm)
Wirefeed Speed Range	100 - 600 IPM (2.5 - 15.2 m/min)
Dimensions (H x W x D)	16.14" x 8.27" x 17.72" (410 x 210 x 450mm)
Weight	32.2 lbs. (14.6 kg)

The Tweco® Fabricator 141i is the only product of its kind. It features MIG, Stick and TIG processes – complete in one unit. It's the lightweight system that has changed the game.

This portable powerhouse is designed to take on any MIG, Stick or TIG job it meets. It delivers up to 140 Amps of welding power and weighs less than 33 lbs.

The compact 141i delivers the flexibility you need in the field, including applications like:

- Automotive Repair & Customization
- Farm and Ranch
- Training Institutions
- Maintenance & Repair
- Sheet Metal & Light Fabrication
- On-site & Portable Welding Applications
- Home Hobbyists (DIY)

3-processes. One machine. There's never been a portable power system like this before.



Primary Power

Primary voltage	115VAC
Supply plug	NEMA 5-20P
Lead cord length	10 ft. (3 m)
Max input current	41.5 Amps
Rated kVA	5 kVA

Package Options

• Fabricator 141i package	W1003141
• Fabricator 141i package w/ Cart	W1003142

Part No.

MIG/FLUX CORED WELDERS

Thermal Arc Fabricator 181i



Fabricator® 181i Part No. W1003181 3-in-1 Welding System

ARC WELDING

Machine Specifications

Maximum output	180 Amp
MIG (GMAW/FCAW) Welding	180A / 23V @ 20% Duty Cycle
Output @104°F (40°C)	145A / 22.5V @ 30% Duty Cycle
STICK (SMAW) Welding	175A / 27V @ 20% Duty Cycle
Output @104°F (40°C)	140A / 25.6V @ 30% Duty Cycle
TIG (GMAW) Welding	175A / 17V @ 25% Duty Cycle
Output @104°F (40°C)	160A / 16.4V @ 30% Duty Cycle
Current range	10 - 180 Amp
MIG Welding Voltage Range	10 - 25 Volt
Wire Diameter Range	Mild steel: .023" - .035" (0.6 - 0.9mm)
	Stainless steel: .023" - .035" (0.6 - 0.9mm)
	Aluminum: .030" - .035" (0.8 - 0.9mm)
	Flux cored: .030" - .045" (0.8 - 1.2mm)
Fitted feed roll suits MIG wire	.023" - .030" / .035" (0.6 - 0.8 / 0.9mm)
Dimensions (H x W x D)	16.14" x 8.27" x 17.72" (410 x 210 x 450mm)
Weight	32.2 lbs. (14.6 kg)

The Thermal Arc® Fabricator 181i is the only product of its kind. It features MIG, Stick and TIG processes – complete in one unit. It's the lightweight system that has changed the game.

This portable powerhouse is designed to take on any MIG, Stick or TIG job it meets. It delivers up to 180 Amps of welding power and weighs less than 33 lbs.

The compact 181i delivers the flexibility you need in the field, including applications like:

- Automotive
- Farm and Ranch
- Light Fab Professionals
- Technical Hobbyists
- Welders
- Do-It-Yourselfers
- Construction
- Manufacturing
- Maintenance & Repair
- Educational Institutions

3-processes. One machine. There's never been a portable power system like this before.



Primary Power

Primary voltage	208/230 VAC
Supply plug	NEMA 6-50P
Lead cord length	9 ft. (2.75m)
Maximum input current @ 140 Amp	37 Amp
Rated kVA @ 90 Amps	9 kVA

Package Options

Package Options	Part No.
• Fabricator 181i package	W1003181
• Fabricator 181i package w/ Cart	W1003182

Fabricator® 181i Part No. W1003188 Auto-Pak™ 3-in-1 Welding System

Complete Welding Package for Automotive*

Package Includes:

- Fabricator® 181i 3-in-1™ Welding System

PLUS:

- E70S-6 Welding Wire, .023", 2 lbs.
- E70S-6 Welding Wire, .030", 2 lbs.
- Welding Gloves
- Tweco® 11-23 Tips, .023", (25 qty)
- Tweco 11-30 Tips, .030", (25 qty)
- Welper MIG Pliers
- Auto-Darkening Helmet**

*TIG Torch sold separately.

**Welding helmet ships separately.



ARC WELDING

Fabricator® 181i Part No. W1003189 Farm-Pak™ 3-in-1 Welding System

Complete Welding Package for Farm & Ranch*

Package Includes:

- Fabricator 181i 3-in-1 Welding System

PLUS:

- E6013 Electrodes, 1/8", 1 lb.
- E6018 Electrodes, 1/8", 1 lb.
- Welding Gloves
- E71T-GS, .035", 2 lbs.
- Tweco 11-35 Tips, .035", (25 qty)
- Chipping Hammer
- Wire Brush
- Auto-Darkening Helmet**

*TIG Torch sold separately.

**Welding helmet ships separately.



MIG/FLUX CORED WELDERS

Thermal Arc Fabricator 211i



Fabricator® 211i Part No. W1004201 3-in-1 Welding System

ARC WELDING

Machine Specifications

Maximum output	210 Amp
MIG (GMAW/FCAW) Welding	110A / 19.5V @ 45% Duty Cycle (115V)
Output @104°F (40°C)	210A / 23.5V @ 20% Duty Cycle (230V)
STICK (SMAW) Welding	110A / 24.8V @ 35% Duty Cycle (115V)
Output @104°F (40°C)	200A / 25V @ 25% Duty Cycle (230V)
TIG (GMAW) Welding	150A / 16V @ 35% Duty Cycle (115V)
Output @104°F (40°C)	200A / 18V @ 25% Duty Cycle (230V)
Current range	5 - 150 Amp (115V), 5 - 210 Amp (230V)
MIG Welding Voltage Range	14 - 30 Volt
Wire Diameter Range	Mild steel: .023"- .035" (0.6 - 0.9 mm)
	Stainless steel: .023"- .035" (0.6 - 0.9 mm)
	Aluminum: .030"- 3/64" (0.8 - 1.2 mm)
	Flux cored: .030"- .045" (0.8 - 1.2 mm)
Wirefeed Speed Range	100 - 600 IPM (2.5 - 15.2 m/min) @ 230V
	100 - 400 IPM (2.5 - 10.2 m/min) @ 115V
Dimensions (H x W x D)	H 17.32" x W 10.23" x D 23.62" (440 mm x 260 mm x 600 mm)
Weight	57.3 lbs. (26 kg)

The Thermal Arc® Fabricator 211i features MIG, Stick and TIG processes – complete in one unit. It's the system that has changed the game.

This portable powerhouse is designed to take on any MIG, Stick or TIG job it meets. It delivers up to 210 Amps of welding power and weighs less than 58 lbs.

The 211i delivers the flexibility you need in the field, including applications like:

- Automotive Repair & Customization
- Farm and Ranch
- Training Institutions
- Maintenance & Repair
- Sheet Metal & Light Fabrication
- On-site & Portable Welding Applications
- Home Hobbyists (DIY)

3-processes. One machine. There's never been a portable power system like this before.



Primary Power

Primary voltage	115VAC, 208/230VAC
Supply plug	NEMA 6-50P
Lead cord length	9 ft. (2.75m)
Max input current	36.7 Amp (115V), 30 Amps (230V)
Rated kVA	4.5 kVA (115V), 7 kVA (230V)

Package Options

Package Options	Part No.
• Fabricator 211i package	W1004201
• Fabricator 211i package w/ Cart	W1004202
• Fabricator 211i package w/ single cylinder cart	W1004201

MIG/FLUX CORED WELDERS

Thermal Arc Fabricator 252i



Fabricator® 252i Part No. W1004401 3-in-1 Welding System

ARC WELDING

Machine Specifications

Maximum output	300 Amp
MIG (GMAW/FCAW) Welding Output @104°F (40°C)	250A / 26.5V @ 40% Duty Cycle 200A / 24V @ 60% Duty cycle 150A / 21.5V @ 100% Duty Cycle
STICK (SMAW) Welding Output @104°F (40°C)	230A / 29.2V @ 40% Duty Cycle 200A / 28V @ 60% Duty cycle 150A / 26V @ 100% Duty Cycle
TIG (GMAW) Welding Output @104°F (40°C)	250A / 20V @ 40% Duty Cycle 200A / 18V @ 60% Duty cycle 150A / 16V @ 100% Duty Cycle
Current range	5-300 A
MIG Welding Voltage Range	14 - 30 Volt
Wire Diameter Range	Mild steel: .023" - .045" (0.6 - 1.2 mm) Stainless steel: .023" - .035" (0.6 - 0.9 mm) Aluminum: .030" - 3/64" (0.8 - 1.2 mm) Flux cored: .030" - .045" (0.8 - 1.2 mm)
Wirefeed Speed Range	67-700 ipm (1.7 – 17.8 m/min)
Dimensions (H x W x D)	H 17.32" x W 10.23" x D 23.62" (440 mm x 260 mm x 600 mm)
Weight	65.3 lbs. (29.6 kg)

The Thermal Arc® Fabricator 252i features MIG, Stick and TIG processes – complete in one unit. It's the system that has changed the game.

This powerhouse is designed to take on any MIG, Stick or TIG job it meets. It delivers up to 300 Amps of welding power and weighs less than 66 lbs.

The 252i delivers the flexibility you need in the field, including applications like:

- Light Industrial Manufacturing
- Mechanical Contractors
- On-Site & Portable Welding Applications
- Automotive Repairs & Customization
- Farms & Ranches
- Training Institutions
- Maintenance & Repairs

3-processes. One machine. There's never been a portable power system like this before.



Primary Power

Primary voltage	Nominal 208/230 VAC
Supply plug	NEMA 6-50P
Lead cord length	9 ft. (2.75m)
Max input current	39.5 Amps
Rated kVA	8.2 kVA

Package Options

Package Options	Part No.
• Fabricator 252i package	W1004401
• Fabricator 252i package w/ single cart	W1004202
• Fabricator 252i package w/ dual cart	W1004403

MIG/FLUX CORED WELDERS

Thermal Arc® FP-95
Thermal Arc® FP-125

ARC WELDING

FP-95 Part No. 1444-0322 Flux Cored Welding System

Machine Specifications

Maximum output	90 Amp
Duty cycle @ 104°F	15% @ 80 Amp at 17.5V
Current range	20-90 Amp
Number of voltage settings	2
Maximum plate thickness	3/16" (4.8mm)
Wire diameter range	.030" - .035" (0.8 - 0.9mm)
Dimensions (HxWxD)	11" x 7.75" x 14.5" (340x195x370mm)
Weight	45 lbs. (20.6kg)

The portable FP-95 flux-cored wire welder delivers a basic yet effective welding performance. With its simple operation and key set up chart even the novice can achieve high quality, professional results. This system is designed to operate from a standard household outlet and delivers a maximum output of 90 amps. Requiring no shielding gas, it's ideal for outside use. The ready to weld system comes complete with Tweco® WeldSkill® gun, return cable & clamp, input power cored & plug, spool of flux cored wire and an operating manual. Optional cart also available.



Applications Include:

- Home DIY Hobbyist
- Farm / Ranch
- Maintenance & repairs

Primary Power

Primary voltage	120 Volt
Supply plug	NEMA 5-15P
Lead cord length	4 ft. (1.2m)
Rated kVA @ 90 Amps	2.5 kVA

FP-125 Part No. 1444-0324 MIG/Flux Cored Welding System

Machine Specifications

Maximum output	110 Amp
Duty cycle @ 104°F	20% @ 88 Amp at 18V
Current range	20-125 Amp
Number of voltage settings	4
Maximum plate thickness	1/4" (6mm)
Wire diameter range	.023" - .035" (0.6 - 0.9mm)
Dimensions (HxWxD)	12.75" x 9.75" x 17.35" (375x250x440mm)
Weight	51 lbs. (23.5kg)

The FP-125 dual-purpose MIG welder offers maximum versatility. The unit features quick-change internal polarity adjustment that makes changing from MIG (GMAW) to flux cored (FCAW) welding quick and easy. With a standard 115 volt household current, it is suitable to use for home projects, but its versatility and 20% duty cycle also makes it ideal for medium duty general repair work and light industrial applications.



Applications include:

- Maintenance & repairs
- Farm/Ranch
- Home DIY Hobbyist

Primary Power

Primary voltage	120 Volt
Supply plug	NEMA 5-15P
Lead cord length	6 ft. (1.8m)
Rated kVA @ 90 Amps	2.8 kVA

FP-135 Part No. 1444-0326 MIG/Flux Cored Welding System

ARC WELDING

Machine Specifications

Maximum output	135 Amp
Duty cycle @ 104°F	40% @ 90 Amp at 18V
Current range	20-135 Amp
Number of voltage settings	4
Maximum plate thickness	1/4" (6mm)
Wire diameter range	.023" - .035" (0.6 - 0.9mm)
Dimensions (HxWxD)	12.75" x 9.75" x 17.35" (375x250x440mm)
Weight	56 lbs. (25.5kg)

The portable FP-135 dual purpose wire welder delivers a very versatile and effective welding performance. With its simple operation and key set up chart even the novice can achieve high quality, professional results. This system features a quick change internal polarity adjustment to change between MIG (GMAW) and flux cored (FCAW) welding. Designed to operate from a standard household outlet and delivers a high maximum output of 135 amps. The ready to weld system comes complete with Tweco® WeldSkill® gun, return cable & clamp, input power cord & plug, spool of flux cored wire, regulator and an operating manual. FP-135's high output and duty cycle makes this a great all round package. Optional cart also available.

Applications Include:

- Home DIY Hobbyist
- Farm / Ranch
- Maintenance and repairs
- General light duty fabrication & repair

Primary Power

Primary voltage	120 Volt
Supply plug	NEMA 5-15P
Lead cord length	6 ft. (1.8m)
Rated kVA @ 90 Amps	2.8 kVA



FP-135 Welding Kit Part No. 1444-0346

Package Includes:

- FP135 MIG Welder
- MIG Welder Cart
- Wire Brush
- Auto-Darkening Helmet
- Chipping Hammer
- Regulator

FP-165 Part No. 1444-0328 MIG/Flux Cored Welding System

Machine Specifications

Maximum output	165 Amp
Duty cycle @ 104°F	20% @ 130 Amp at 30V
Current range	20-165 Amp
Number of voltage settings	4
Maximum plate thickness	3/8" (9mm)
Wire diameter range	.023" - .035" (0.6 - 0.9mm)
Dimensions (HxWxD)	12.75" x 9.75" x 17.35" (375x250x440mm)
Weight	60 lbs. (27.3kg)

The portable FP-165 dual purpose wire welder delivers a very versatile and effective welding performance. With its simple operation and key set up chart even the novice can achieve high quality, professional results. This system features a quick change internal polarity adjustment to change between MIG (GMAW) and flux cored (FCAW) welding. Designed to operate from a standard 230V outlet and delivers a high maximum output of 165 amps. The ready to weld system comes complete with Tweco® WeldSkill® gun, return cable & clamp, input power cord & plug, spool of flux cored wire, regulator and an operating manual. Optional cart available.

Applications Include:

- Home DIY Hobbyist
- Farm / Ranch
- Maintenance and repairs
- General light duty fabrication & repair



Primary Power

Primary voltage	230 Volt
Supply plug	NEMA 6-50P
Lead cord length	6 ft. (1.8m)
Rated kVA @ 90 Amps	2.8 kVA



FP-165 Welding Kit Part No. 1444-0348

Package Includes:

- FP165 MIG Welder
- MIG Welder Cart
- Wire Brush
- Auto Darkening Helmet
- Chipping Hammer
- Regulator

FP-260 Part No. 1444-0312 Welding System

ARC WELDING

Machine Specifications

Maximum output	270 Amp
Duty cycle @ 104°F	60% @ 200 Amp at 30V
Current range	20-270 Amp
Number of voltage settings	7
Maximum plate thickness	5/8" (16mm)
Wire diameter range	.023" - .045" (0.6 - 1.2mm)
Dimensions (HxWxD)	31" x 19.5" x 33" (375x250x440mm)
Weight	60 lbs. (27.3kg)

The FP-260 dual purpose wire welder delivers a very versatile and effective welding performance. This system features a quick change internal polarity adjustment to change between MIG (GMAW) and flux cored (FCAW) welding. Designed to operate from a standard 230V outlet and delivers a high maximum output of 270 amps. The ready to weld system comes complete with Tweco® WeldSkill® gun, return cable & clamp, input power cord & plug and an operating manual. This system offers industrial grade performance at an affordable price. A spool gun option for welding aluminum is also available.

Applications Include:

- Home DIY Hobbyist
- Farm / Ranch
- Maintenance and repairs
- General light duty fabrication & repair
- Light industrial



Primary Power

Primary voltage	230 Volt
Supply plug	NEMA 6-50P
Lead cord length	10 ft. (3m)
Rated kVA @ 190 Amps	11.2 kVA

Tweco® Fusion MIG Guns

(For part numbers see chart on next page.)



Tweco Fusion™ 140, 180 & 220

140 Amps @ 20% Duty Cycle • 180 Amps @ 40% Duty Cycle • 220 Amps @ 40% Duty Cycle

- Typical applications: light fabrication, welding of HVAC, architectural metal work, DIY, hobby, farm and autobody
- Operator appeal with ergonomic handle with diamond pattern for better grip
- Uses new high performance Velocity™ consumables
- Long-life microswitch trigger design
- Rugged with steel spring strain relief

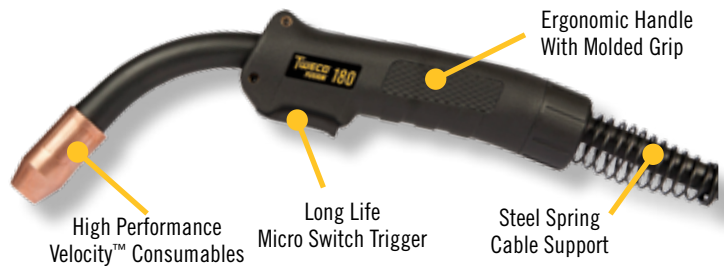

Tweco Fusion 250

250 Amps @ 80% Duty Cycle

- Typical applications: general light fabrication, production welding, auto-body, RV/campers, farm equipment
- Operator appeal with ergonomic handle with extended trigger length
- Uses new high performance Velocity™ consumables
- High output / high duty cycle
- Rugged with steel spring strain relief



Tweco Velocity™ MIG Welding Consumables

Tweco Fusion™ MIG Guns come standard with Velocity™ Consumables

- Solid copper conductor path with fewer connections
- Optimized electrical surface contact
- Optimized wire feedability with centered liner
- Fewer consumable parts to replace – lower cost of ownership
- Easy to change Velocity tips – No threads, no tools required
- Tips can be rotated to optimize life requiring fewer changes
- Superior welding performance from a smooth, stable arc



VELOCITY™ CONSUMABLES	
Velocity™ Nozzles	Velocity™ Contact Tips
VNS-50F	VTS-23
VNS-50	VTS-30
VNS-37F	VTS-35
VNS-37	VTS-40
VNS-62F	VTS-45
VNS-62	VTS-364
VNS-75FAS	V TSA-364
VNS-FC	VTS-52
VNS-FCI*	VTS-116
	V TSA-116
	VTS-564

*Insulator for the flux-cored tip holder

Tweco® Fusion MIG Guns

TWECO FUSION™ MIG GUNS SELECTION CHART						
Amps	MIG Gun	DIY/Hobby	Farm	MRO	Autobody	Light Fab
≤ 150 Amps	Best Fit: Tweco Fusion 140 Alternate Fit: Tweco Fusion 180	Best	Good	Good	Best	
150 – 200 Amps	Best Fit: Tweco Fusion 180 Alternate Fit: Tweco Fusion 220	Best	Best	Best	Best	
200 – 250 Amps	Best Fit: Tweco Fusion 220 Alternate Fit: Tweco Fusion 250	Good	Best	Best	Best	Best
≥ 250 Amps	Best Fit: Tweco Fusion 250		Best	Best	Best	Best

TWECO FUSION™ MIG GUNS				
Rear Connection	Tweco Fusion™ 140 Part Number	Tweco Fusion™ 180 Part Number	Tweco Fusion™ 220 Part Number	Tweco Fusion™ 250 Part Number
Thermal Arc® (8 Pin)	1017-1321	1017-1332	1023-1261	1023-1097
Tweco® (4 Pin)	1017-1320	1017-1331	1023-1260	1023-1061
Miller®	1017-1319	1017-1330	1023-1259	1023-1069
Lincoln®	1017-1318	1017-1329	1023-1258	1023-1085
Euro-Kwik	1017-1323	1017-1334	1023-1263	1023-1091

POWER SUPPLY COMPATIBILITY				
Thermal Arc® Connector (8 Pin)	Tweco® Connector (4 Pin)	Miller® Connector	Lincoln® Connector	Euro-Kwik Connector
Thermal Arc® Fabricator 141i, 181i, 211i & 252i	Thermal Arc® Fabricator 190, 210, 251 & 281 Lincoln® SP100, SP100T, SP125 Plus, SP130, SP170T & SP170 Plus Hobart® Beta Mig 170	Millermatic® 130, 130 XP, 135, 140, 150, 155, 175, 180, 185, 200, 210, 211, 212 Hobart® Handler 130XL, 210, Trek 180, Ironman™ 210	Lincoln® SP140T, SP180T, PowerMIG® 140C & 180C, Easy-Core™ 125, Pro-Core™ 125, Easy-MIG® 140, Weld-Pak 125HD, 140HD & 180HD, MIG-Pak™ 140 & 180, Easy-MIG® 180, Pro-MIG™ 140 & 180	ESAB® MigMaster® 160 & 173

ESAB and MigMaster are registered trademarks of ESAB AB. Ironman is a trademark and Hobart, Miller, and Millermatic are a registered trademarks of Illinois Tool Works, Inc. Easy-Core, MIG-Pak, Pro-Core, and Pro-MIG are trademarks and Lincoln, Easy-MIG and Power-MIG are registered trademarks of Lincoln Electric Company. The aforementioned trademarks and their respective owners are in no way affiliated with Victor Technologies International, Inc. Tweco Fusion and Velocity are trademarks and Tweco and Thermal Arc are registered trademarks of Victor Technologies International, Inc.

Tweco® MINI-MIG Gun

The 160 amp, air-cooled Tweco Mini MIG gun is ideal for light-duty, hobby-style do-it-yourself welding applications.

Duty cycle rating

- 60% duty cycle with CO₂ gas at 160 amps

Benefits & features

Reduces operator fatigue

- Light-duty hobby gun

Easy to use

- Designed for do-it-yourself application

Out-of-the-box welding

- Fully assembled, ready to use MIG gun

Included features

- Air-cooled MIG gun
- Wire size capacity .030" - .035" (0,8mm - 0,9mm)
- Gun lengths in 10 ft. (3M) and 12 ft. (4M)

Optional kits

- Kits for Miller® rear connection and Lincoln® rear connection

Part No. 1000-1131; 10 ft. (3M)

Part No. 1000-1132; 12 ft. (4M)

Part No. 1000-1101; MIG Hobby Kit for Miller rear connection

Part No. 1000-1100; MIG Hobby Kit for Lincoln rear connection



Tweco Spray Master® 250 MIG Gun

The 250 amp, air-cooled Tweco Spray Master is the coolest MIG gun for spray transfer welding applications.

Duty cycle rating

- 80% duty cycle with Argon mixed gas at 250 amps

Benefits & features

Reduces operator fatigue

- With its ergonomic handle design

Ease of installation and ease of use

- With its simplified direct rear plug

Easy to repair and maintain

Improves welding productivity

- By using spray and pulse transfer welding with Argon mixed gases
- Reduces spatter build-up and thereby reduces spatter clean-up time

Out-of-the-box welding

- Fully assembled, ready to use MIG gun

Included features

- Air-cooled MIG gun
- Wire size capacity .030" - .045" (0,9mm - 1,2mm)
- Gun lengths in 12 ft. (4M) and 15 ft. (5M)

Part No. 1023-1101; 12 ft. (4M)

Part No. 1023-1102; 15 ft. (5M)



Miller is a registered trademark of Illinois Tool Works, Inc. Lincoln is a registered trademark of Lincoln Electric Co. The afore mention registered trademarks are in no way affiliated with Tweco or Victor Technologies Industries, Inc.

Tweco® Classic #2 MIG Gun

The 200 amp, air-cooled Tweco #2 MIG gun is professional's choice for air-cooled 200 amp MIG welding application.

Duty cycle rating

- 60% duty cycle with CO₂ gas at 200 amps

Benefits & features

Most preferred gun style

- Industry's most popular handle design

Enhanced toughness

- Higher impact resistant materials
- Improved structural design

Improved durability

- Higher strength interlocking handle design

Higher performance

- Refined ergonomics with angled trigger

Included features

- Air-cooled MIG gun
- Wire size capacity .030" - .035" (0,8mm - 0,9mm)
- Gun lengths in 10 ft. (3M), 12 ft. (4M), and 15 ft. (5M)

Part No. 1020-1111; 10 ft. (3M)

Part No. 1020-1112; 12 ft. (4M)



Tweco® WeldSkill® Spool Guns

Benefits & features

- Excellent service and ease of operation
- Comfortable handle design
- Quick disconnect conductor tube
- Adapts to most welding machines
- Easy to use
- Designed for do-it-yourself application

160 Amp 20% Duty Cycle

Part No. 1027-1390

(for use on Thermal Arc 141i, 181i, 211i)

- Gun length 15 ft. (5M)

200 Amp 60% Duty Cycle

Part No. 1027-1391

(10 Pin Amphenol style connector)

- Gun length 25 ft. (8M)

200 Amp 60% Duty Cycle

Part No. 1027-1392

(use only on Thermal Arc 252i power supplies)

- Gun length 25 ft. (8M)



WELDING SYSTEM REPLACEMENT MIG GUNS

ARC WELDING



1444-0406

REPLACEMENT MIG GUNS

Part No.	Description
1444-0406	FP-300 MIG Gun Fits FP 200, FP 260 Welders Euro Connect Maximum Output Amps 230/270
1444-0413	FP-200 MIG Gun Fits FP 120, FP 130, FP 160 Welders Maximum Output Amps 120/155 Requires adaptor
1444-0740	Max output amps 180
1444-0741	Max output amps 180
1444-0417	Adaptor for use with Model 1444-0413. Adaptor is required only when replacing a Tweco® style MIG gun with a Helvi gun

180 AMP SPOOL GUN



Spool gun assembly with 19 ft. cable, 180 Amp @ 30%. No interface kit required, just plug and play. **Part No. W4011100**

MIG NOZZLE INSULATORS



MIG NOZZLE INSULATORS

Part No.	Description
1444-0075	FP-32 Insulator for 250 amp gun (2 pk)
1444-0261	FP-34A Insulator for 400 amp gun (2 pk)

GAS DIFFUSERS



GAS DIFFUSERS

Part No.	Description
1444-0080	FP-51 Diffuser for 180 amp gun (2 pk)
1444-0165	FP-52 Diffuser for 250 amp gun (2 pk)
1444-0265	FP-54A Diffuser for 400 amp gun (2 pk)
1444-0082	FP-35-50 Male Thread diffuser for Tweco style gun
1444-0489	FP-35 Female Thread diffuser for Tweco style gun

Fabricator® MIG Consumables

CONTACT TIPS

Part No.	Description
Fabricator 140, 180, 190	
1110-1100	11-23; .023" (0.6mm)
1110-1101	11-30; .030" (0.8mm)
1110-1102	11-35; .035" (0.9mm)
1110-1103	11-40; .040" (1.0mm)
1110-1104	11-45; .045" (1.2mm)
Fabricator 210	
1140-1100	14-23; .023" (0.6mm)
1140-1101	14-30; .030" (0.8mm)
1140-1102	14-35; .035" (0.9mm)
1140-1103	14-40; .040" (1.0mm)
1140-1104	14-45; .045" (1.2mm)
Fabricator 251 and 281	
1140-1100	14-23; .023" (0.6mm)
1140-1101	14-30; .030" (0.8mm)
1140-1102	14-35; .035" (0.9mm)
1140-1103	14-40; .040" (1.0mm)
1140-1104	14-45; .045" (1.2mm)



11-23

NOZZLES

Part No.	Description
Fabricator 140, 180, 190	
1210-1100	21-37; 3/8" (9.5mm)
1210-1110	21-50; 1/2" (12.7mm)
1210-1120	21-62; 5/8" (16mm)
Fabricator 210	
1220-1101	22-37; 3/8" (9.5mm)
1220-1110	22-50; 1/2" (12.7mm)
1220-1120	22-62; 5/8" (16mm)
Fabricator 251 and 281	
1240-1101	24A-37-SS; 3/8" (9.5mm)
1240-1110	24A-50; 1/2" (12.7mm)
1240-1120	24A-62; 5/8" (16mm)
1240-1130	24A-75; 3/4" (19mm)



24A-50

CONDUITS

Part No.	Description
Fabricator 140, 180, 190 and 210	
1420-1103	42-23-15; .023", 15ft (7.6m)
1420-1113	42-3035-15; .030"-.035", 15ft (4.5m)
1420-1123	42-4045-15; .040"-.045", 15ft (4.5m)
Fabricator 251 and 281	
1420-1103	42-23-15; .023", 15ft (7.6m)
1420-1113	42-3035-15; .030"-.035", 15ft (4.5m)
1440-1103	44-3545-15; .035"-.045", 15ft (4.5m)
1440-1003	44N-3545-15; .035"-3/64", 15ft (4.5m)



42-3035-15

FABRICATOR MIG GUN OPTIONS:

MIG gun options	Fabricator 190	Fabricator 210	Fabricator 251 / 281
Tweco® MINI-MIG gun	YES	YES	–
Tweco Spray Master® 250	YES	YES	YES
Tweco Professional #2	YES	YES	–
Tweco Professional #4	–	–	YES
Tweco WeldSkill® Spool Gun	–	YES	YES
Single Cylinder Rack	–	YES	YES

180 AMP MIG GUN CONTACT TIPS



180 Amp MIG Gun Contact Tips

Part No.	Description
A 1444-0025	FP11-23, .023 wire, Tip ID .031 (10 pk)
B 1444-0026	FP11-30, .030 wire, Tip ID .038 (10 pk)
C 1444-0027	FP11-35, .035 wire, Tip ID .044 (10 pk)
D 1444-0028	FP11-40, .040 wire, Tip ID .048 (10 pk)
E 1444-0029	FP11-45, .045 wire, Tip ID .054 (10 pk)

FP = Firepower®

250 & 400 AMP MIG GUN CONTACT TIPS

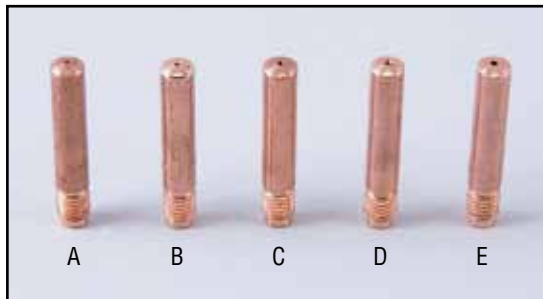

250 & 400 Amp MIG Gun Contact Tips

Part No.	Description
A 1444-0220	FP14-23, .023 wire, Tip ID .031 (10 pk)
B 1444-0221	FP14-30, .030 wire, Tip ID .038 (10 pk)
C 1444-0222	FP14-35, .035 wire, Tip ID .044 (10 pk)
D 1444-0223	FP14-40, .040 wire, Tip ID .048 (10 pk)
E 1444-0224	FP14-45, .045 wire, Tip ID .054 (10 pk)

MIG GUN NOZZLES

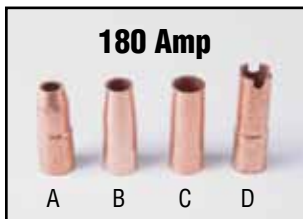

Nozzles - 180 Amp Guns

Part No.	Description
A 1444-0050	FP21-37, 3/8" Bore (1pk)
B 1444-0051	FP21-50, 1/2" Bore (1pk)
C 1444-0052	FP21-62, 5/8" Bore (1pk)
D 1444-0053	FP21-62-FAS, 5/8" Bore, Arc Spot (1pk)

Nozzles - 250 Amp Guns

Part No.	Description
A 1444-0140	FP22-50, 1/2" Bore (1pk)
B 1444-0141	FP22-62, 5/8" Bore (1pk)
C 1444-0142	FP22-62-FAS, 5/8" Bore, Arc Spot (1pk)

Nozzles - 400 Amp Guns

Part No.	Description
A 1444-0240	FP24A-50, 1/2" Bore (1pk)
B 1444-0241	FP24A-62, 5/8" Bore (1pk)
C 1444-0242	FP24A-62-FAS, 5/8" Bore, Arc Spot (1pk)

Thermal Arc® 95 S Inverter Part No. W1003202 Stick/Lift TIG Welding System

Machine Specifications

Input voltage	115 VAC 1 Phase 50/60Hz
Rated output	Stick 90 Amp / 23.6V @ 20% TIG 95 Amp / 13.8V @ 20%
Nominal OCV	60 Volt
SMAW Electrode Range	1/16" - 3/32"
GTAW DC Tungsten Range	.040" - 3/32"
Dimensions (HxWxD)	13" x 5.1" x 9.0" (330x130x230mm)
Weight	9.7 lbs. (4.4kg)

The Thermal Arc 95 S Inverter is a versatile multi-process machine with stick and lift TIG capability. With up to 95 amps of welding power it delivers excellent performance on a wide variety of materials. In DC Lift TIG mode the 95 S provides 95 amps of welding power suitable for a wide range of materials from Chrome-Moly and steel tubing to general fabrication of mild and stainless steels. Delivering a superior smooth and stable arc performance down to 5 amps for the thinnest of materials. Extremely lightweight and portable yet designed to handle the toughest jobs.

Applications include:

- Maintenance and repairs
- Sheet metal fabrication
- Farm/Ranch
- Auto body repair
- Home DIY Hobbyist



Above: 95S Stick (SMAW) package option - part no. W1003203

Primary Power

Primary voltage	115 Volt
Supply plug	NEMA 5-15P
Lead cord length	6 ft. (1.8m)
Maximum input current @ 140 Amp	24 Amp
Rated kVA @ 190 Amps	2.8 kVA

Package Options

Package Options	Part No.
• 95S Stick (SMAW) package	W1003202
• 95S TIG (GTAW) package	W1003203

Thermal Arc® 161 S Stick/Lift TIG Welding System Part No. W1003602

ARC WELDING

Machine Specifications

Input Voltage	115/208-230 VAC, 1 PH, 50/60 Hz
Rated Output 115V	Stick 100A/ 24V @35%, TIG 110A/ 14.4V @30%
Rated Output 230V	Stick 160A/ 26.4V @30%, TIG 160A/ 16.4V @30%
Nominal OCV	71V
Max OCV	65
Dimensions (HxWxD)	9.0" (229mm) x 5.3" (135mm) x 15.5" (394mm)
Weight	17.4 lbs. (7.9kg)

The Thermal Arc 161 S Portable DC Welder is designed for Stick & Lift TIG welding operations and provides a greater range of output for the advanced hobbyist or light industrial applications. It is capable of delivering 110 Amps on 115 Volt circuits for Stick & TIG welding. When used on 208-230 Volt circuits, maximum output is 160 Amps for either welding process. This welder features optimized hot start and arc-force circuits delivering superior arc starting and control when stick welding.

Applications include:

- Home Hobbyists
- Farm and ranch
- Educational institutions
- Maintenance and Repair



Primary Power

Primary voltage	115/208-230V
Hertz	50/60 Hz
Phase	1 PH
Designed to	IP23S
Approvals EN	60974-1

Package Options

- 161 S TIG (GTAW) package

Part No.

W1003603

Above: 161 S Stick (SMAW) package option - part no. W1003602

Thermal Arc® 201 TS Stick/Lift TIG Welding System Part No. W1003801

ARC WELDING

Machine Specifications

Rated Output:	
Stick 115V, 15A	22.8V @ 70%
TIG 115V, 15A	14V @ 60%
Stick 115V, 20A	24.4V @ 30%
TIG 115V, 20A	16.4V @ 30%
Stick 230V 200A	28.0V @ 20% TIG 230V 200A / 18.0V @ 20%
Nominal OCV	71V
Dimensions (HxWxD)	9.0" (229mm) x 5.3" (135mm) x 17.7" (450mm)
Weight	21.6 lbs. (9.7kg)

The Thermal Arc 201 TS Portable DC Welder packs a serious punch and is ideal for tradesmen or welders with more demanding requirements. Powerful yet compact and portable, the 201TS can deliver 125 Amps on 115 Volt circuits for Stick welding and 160 Amps for TIG. When used on 208-230 Volt circuits, maximum output is 200 Amps for either welding process. The 201 TS features optimized hot start and user adjustable arc-force circuits delivering superior arc starting and control when Stick welding. The power source has High Frequency or Lift TIG circuitry for TIG welding and includes a trigger hold function (2T/4T), down slope timer, gas solenoid for flow through gas and the ability to use torch switch or foot control accessories. The TIG torch included in the package has an integrated amperage control dial and on/off switch, which allows for the ultimate in welding control and simplicity.



Applications include:

- Home Hobbyists
- Farm and ranch
- Educational institutions
- Maintenance and Repair

Primary Power

Primary voltage	115/208-230V
Hertz	50/60 Hz
Phase	1 PH
Designed to	IP23S
Approvals EN	60974-1

Package Options

- | Package Options | Part No. |
|---------------------------------|----------|
| • 201 TS Stick/Lift TIG package | W1003801 |

Thermal Arc® 95 S, 161 S and 201 TS Consumables

ARC WELDING



Consumable/Replacement Parts	
Part No.	Description
1442-0002	Backcap
1442-0003	Collet .040
1442-0004	Collet 1/16"
1442-0005	Collet 3/32"
1442-0006	Collet Body .040
1442-0007	Collet Body 1/16"
1442-0008	Collet Body 3/32"
1442-0009	Cup Alumina 4
1442-0010	Cup Alumina 5
1442-0011	Cup Alumina 6
1442-0012	TIG Accessory Kit
1442-0013	Tungsten .042 2% Thoriated
1442-0014	Tungsten 1/16" 2% Thoriated
1442-0015	Tungsten 3/32" 2% Thoriated
W4012500	17V TIG Torch, Complete, 25mm Connection



Thermal Arc TIG Torches & Accessories

Part No. W4013802 (for 181i)

17V, 13 ft, 8 pin and accessory kit with: 1/16", 3/32", 1/8" thoriated tungstens; 1/16", 3/32", 1/8" collets; 1/16", 3/32", 1/8" collet bodies; No. 5, 6, 7 Alumina nozzle; short back cap; long back cap.

Part No. W4012500 (for 95 S)

17V, 25mm Dinse connection

Part No. W4012600 (for 161 S)

17V, 50mm Dinse connection

Part No. W4014603 (for 211i)

26V, 50mm Dinse connection

Part No. W4013600 (for 252i, 201 TS, 186 AC/DC)

26V, 50mm Dinse connection



FP-100 Part No. 1443-0412 Welding System

ARC WELDING

Machine Specifications

Output range	5-85 amps (120V)
Rated Output @ Duty Cycle	65A @ 15% Duty Cycle (120V)
Max OCV	65
Consumable Size	1/16" to 3/32" STICK electrode
Dimensions (HxWxD)	11.5" x 9" x 13.3" (290x225x338mm)
Weight	27 lbs. (12kg)

Enjoy the convenience of arc welding repairs at an affordable price. The FP-100 operates on standard 120 volt household current and is designed to be simple to operate. The FP-100 portable arc welding system features AC welding output as well as infinite amperage control making it easy for even novice welders to obtain professional results. The rugged easy grip handle and its light weight make this unit both practical and portable. The FP-100 is ideal for home, farm and light maintenance repairs.

Applications include:

- Home DIY hobbyist
- Farm/ranch
- Maintenance & repairs
- General fabrication



Primary Power

Primary voltage	120 Volt
Supply plug	NEMA 5-15P
Lead cord length	6 ft. (1.8m)
Rated kVA @ 85 Amps	2.5 kVA

FP-235 AC/DC Part No. 1443-0416 Welding System

ARC WELDING

Machine Specifications

Output range	20-235 amps (230V)
Rated Output @ Duty Cycle	200A @ 20% AC Duty Cycle 135A @ 20% DC Duty Cycle
Max OCV	65
Consumable Size	1/16" - 5/32" STICK electrode
Dimensions (HxWxD)	23" x 17.5" x 14" (597x441x360mm)
Weight	113 lbs. (51kg)

The FP-235 AC/DC provides powerful 235 Amp AC/185 Amp DC Arc (SMAW) welding performance at an affordable price. DC output produces better visual welds, with more control and less splatter. Its the preferred method for overhead out of position welding. The FP-235 features infinite amperage adjustment, which provides precise welding control. This versatile unit is ideal for both light and heavy-duty repairs. The FP-235's rugged, portable design delivers the reliability and performance to make it an ideal unit for general fabrication as well as farm, ranch, automotive and light maintenance repairs.

Applications include:

- Home DIY hobbyist
- Farm/ranch
- Maintenance & repairs
- General fabrication



Primary Power

Primary voltage	230V
Supply plug	NEMA 6-50P
Lead cord length	6 ft. (1.8m)

Thermal Arc® 186 AC/DC Part No. W1006301 Portable AC/DC HF TIG System

ARC WELDING

Machine Specifications

Maximum output	200 Amp
STICK (SMAW) Welding Output @104°F (40°C)	170A / 26.6V @ 16% Duty Cycle 150A / 26V @ 25% Duty cycle 150A / 26V @ 100% Duty Cycle
TIG (GMAW) Welding Output @104°F (40°C)	200A / 18V @ 20% Duty Cycle 180A / 17.2V @ 25% Duty cycle 150A / 16V @ 35% Duty Cycle
Current range	10-200 Amps
Dimensions (H x W x D)	H 15.75" x W 9.45" x D 18.7" (400 mm x 240 mm x 475 mm)
Weight	48.4 lbs. (22 kg)

The Thermal Arc 186 AC/DC is a multi-process, complete Stick & TIG system solution ready for any application. Fully featured professional performance capability made easy to use. High output duty cycle, and ready to perform.

Features:

- HF TIG (GTAW)
- Lift TIG (GTAW)
- STICK (SMAW)

Applications include:

- Aluminum Fabricators
- Training Institutions
- Maintenance & Repair
- On-Site & Portable Welding Applications
- Automotive, Boats & Trailers



Primary Power

Primary voltage	Nominal 208/230 VAC
Supply plug	NEMA 6-50P
Lead cord length	9 ft. (2.75m)
Max input current	35.6 Amps
Rated kVA	9.5 kVA

Package Options

	Part No.
• Thermal Arc 186 AC/DC System	W1006301
• Thermal Arc 186 AC/DC System with Foot Pedal	W1006303
• Thermal Arc 186 AC/DC System with Foot Pedal & Cart	W1006304

Welding Carts

Benefits & features

Rugged and durable MIG Welding cart holds welding machine on top tray and a single cylinder rack in the bottom tray and the gas bottle can be securely tied down with chains

Part No. 1444-0407 MIG Welding Cart for FP125, FP135, FP165

Welding Cart



Small Cart with Running Gear/Cylinder Rack

Sturdy construction. For gas cylinders no larger than 7" (178mm) diameter, maximum weight 75 lbs. (34 kg).

Part No. W4011500



FP-2000 Firepower® Air-Carbon Arc Gouging Torch

The Firepower Arc Gouging Torch is the perfect tool for metal removal applications on the farm, in metal shops and much more. The arc gouging process melts the metal with an electric arc and then blows it away with ordinary compressed air in a single pass!

Benefits & features

Reduces operator fatigue

- Natural 15° torch angle and 360° swivel cable provide comfort and operator ease
- Torch weight is only 3.6 lbs. (1.6 kg)

Applications

- Bead removal on welded joints
- Back gouging, edge preparation
- Defect repair

Included features

- Length: 7 ft.
- Rugged construction for the harsh environment

Operating parameters

- Carbon specs: 1/8" (3,2 mm) to 1/4" (6.5mm) round carbon electrodes and is rated up to 450 amps
- Operates with compressed air from 40 PSI (2.8 kg/cm²) to 60 PSI (4.2 kg/cm²)
- Requires a minimum of a 300 amp 3 Phase, arc welding machine. AC or DC; DC preferred

Part No. 1443-0042



Firepower® Electrode Holder

The industry standard for your stick electrode welding applications with 200 amp capacity.

Benefits & features

Long lasting

- Heavy duty, shock-proof nylon handle
- Ball point cable connection

Ease of use and ease of installation

- Reversible top and bottom insulators

Included features

- 6-position jaw pattern to hold welding electrode in place
- Fully insulated
- Supplied with an Allen wrench and cable connection ferrule assuring efficient connection and minimizing cable strand breakage at the connection

Part No. 1443-0015



Tweco® “HOLD-TITE” Electrode Holder

Provides a unique style, with Tweco-style head provides the gripping force to hold the stick electrode in place. It has 400 amp capacity for heavy duty welding applications.

Benefits & features

Long lasting

- Rugged and reliable design
- Ball point cable connection

Ease of use and ease of installation

Included features

- Fully insulated
- Supplied with an Allen wrench and cable connection ferrule assuring efficient connection and minimizing cable strand breakage at the connection

Part No. 9120-1010



Cable Connectors

Part No.	Description	Cable Capacity	Standard Package
9425-1125	1-WPC Complete Set of Connectors	4, 2, 1	1
9425-1225	2-WPC Complete Set of Connectors	1/0, 2/0, 3/0	1



Tweco® Welding Ground Clamps – Steel levers

Comes in 300 amp and 500 amp capacities. These can be used in stick welding, submerged arc welding, gas metal arc welding, gas tungsten arc welding applications for light and medium duty metal fabrication.

Benefits & features

Long lasting

- Heavy duty spring
- Ball point screw to secure the welding cable to the ground clamp

Included features

- Steel upper and lower levers
- Heavy duty spring providing clamping force to the work surface
- Connector body with ball point screw
- Overall length 9"
- Cable connection capacity of 1/2" stud connection

Ease of use and ease of installation with large jaw opening of 2" with jaw opening depth of 1.75"

Part No. 9205-1230 – 300 amp capacity

Part No. 9205-1250 – 500 amp capacity



Tweco Welding Ground Clamps - Copper

Comes in 200 amp and 300 amp capacities. These can be used in stick welding, submerged arc welding, gas metal arc welding, gas tungsten arc welding applications for light and medium duty metal fabrication.

Benefits & features

Long lasting

- Rugged and reliable in design
- Ball point screw to secure the welding cable to the ground clamp

Included features

- Copper cast upper and lower jaws
- Heavy duty spring providing clamping force to the work surface
- Overall length 6" (200 amp) and 8.5" (300 amp)

Ease of use and ease of installation with large jaw opening of depth of 3" (200 amp) and 4" (300 amp)

Part No. 9205-1120 – 200 amp capacity

Part No. 9205-1130 – 300 amp capacity



Tweco Switchable Magnetic Ground Clamps

Can be used as a ground clamp device around pipe and flat applications, or with any large magnetic base metal. It is used to lay the ground clamp magnetically attached to the metal being welded, thus providing the electrical ground.

Benefits & features

Long lasting - rugged and reliable in design

Included features

- 200 amp and 300 amp capacities

Very easy to use and easy to install

- Get a very secure grip by turning the knob and release the grip by turning it back
- These are switchable, meaning that the ground clamp can easily be removed by turning "off" the magnetic function thereby releasing the ground clamp from the base metal structure

Part No. 9255-1060 – 200 amp capacity

Part No. 9255-1061 – 300 amp capacity





Filler Metal



Firepower® Arc Welding Electrodes

Type 6010	1 lb. Box	5 lb. Box	10 lb. Box	50 lb. Box
Rod Size	Part No.	Part No.	Part No.	Part No.
3/32"	N/A	1440-0474	N/A	N/A
1/8"	N/A	1440-0473	N/A	N/A
5/32"	N/A	1440-0475	N/A	N/A

Type 6011	1 lb. Box	5 lb. Box	10 lb. Box	50 lb. Box
Rod Size	Part No.	Part No.	Part No.	Part No.
3/32"	1440-0115	1440-0116	1440-0117	1440-0118
1/8"	1440-0105	1440-0106	1440-0107	1440-0108
5/32"	1440-0095	1440-0096	1440-0097	1440-0098

Type 6013	1 lb. Box	5 lb. Box	10 lb. Box	50 lb. Box
Rod Size	Part No.	Part No.	Part No.	Part No.
3/32"	1440-0145	1440-0146	1440-0147	1440-0148
1/8"	1440-0134	1440-0135	1440-0136	1440-0137
5/32"	1440-0124	1440-0125	1440-0126	1440-0127

Type 7014	1 lb. Box	5 lb. Box	10 lb. Box	50 lb. Box
Rod Size	Part No.	Part No.	Part No.	Part No.
3/32"	1440-0205	1440-0206	1440-0207	1440-0208
1/8"	1440-0200	1440-0201	1440-0202	1440-0203
5/32"	1440-0150	1440-0151	1440-0152	1440-0153

Type 7018	1 lb. Box	5 lb. Box	10 lb. Box	50 lb. Box
Rod Size	Part No.	Part No.	Part No.	Part No.
3/32"	1440-0195	1440-0196	1440-0197	1440-0198
1/8"	1440-0185	1440-0186	1440-0187	1440-0188
5/32"	1440-0180	1440-0181	1440-0182	1440-0183

Features:

Type 6010

- Premium AWS Class E-6010
- Mild steel type
- Deep penetration, welds through rust, scale, oil and dirt
- Excellent for pipe welding, root
- DC, reverse polarity
- 60,000 PSI tensile strength
- All position electrode

Type 6011

- Premium AWS Class E-6011
- Mild steel type
- Deep penetration, welds through rust, scale, oil and dirt
- Use when you are unable to prepared the welding surface
- AC or DC, reverse polarity
- 60,000 PSI tensile strength
- All position electrode

Type 6013

- Premium AWS Class E-6013
- Mild steel type
- Designed for General Purpose
- Excellent for low heat applications
- Best used with clean or prepared welding surface
- AC or DC, reverse polarity
- 60,000 PSI tensile strength
- All position electrode

Type 7014

- Premium AWS Class E-7014
- Iron powder type
- Designed for high deposition and high electrode travel speed
- Medium to low penetration
- Best used with clean or prepared welding surface
- AC or DC, reverse polarity
- 70,000 PSI tensile strength
- All position electrode

Type 7018

- Premium AWS Class E-7018
- Low Hydrogen Type
- Designed to produce X-Ray quality welds
- Medium penetration
- Best used with clean or prepared welding surface
- AC or DC, either polarity
- 70,000 PSI tensile strength
- All position electrode

ELECTRODES, WIRE, & SOLDER

Firepower® Job Packs



FIREPOWER JOB PACKS

Part No.	Description	No. Rods
1440-0400	Bronze Flux Coated Brazing Rods, 3/32" diameter x 14" long No brazing flux needed	4
1440-0401	Bronze Bare Brazing Rods, 3/32" diameter x 14" long Requires brazing flux	4
1440-0402	E4043 Aluminum Welding Electrodes, 1/8" diameter x 14" long Use with ANY Aluminum Application	3
1440-0403	Cutting Electrodes, 1/8" diameter x 14" long Use your Electric Welder as a cutting Torch	3
1440-0405	6013 General Purpose Electrodes, 1/16" x 10" long	4
1440-0406	6013 General Purpose Electrodes, 3/32" diameter x 14" long Excellent for use with all types of Arc Welders	4
1440-0409	6011 Welding Electrodes, 1/8" diameter x 14" long Excellent for Maintenance & Repair Applications	3
1440-0411	Nickel 55 Welding Electrodes, 1/8" diameter x 14" long For ALL Cast-Iron Welding Applications	4
1440-0423	ENiCl Pure Nickel Electrode 3/32" diameter x 14" long	5
1440-0424	ENiCl Pure Nickel Electrode 1/8" diameter x 14" long	3
1440-0440	Cast Iron (60% Nickel) 3/32" diameter x 14" long	3
1440-0441	6011 Mild Steel 3/32" diameter x 14" long	4

Mild Steel Electrodes



E6024 Quick Start Electrodes

Mild steel type electrode has a special quick start tip. Stable arc and automatic action that makes it easy to use on thin metals requiring low amperage. Features self-cleaning action that works well in all positions. Tensile Strength 60,000 PSI.

Current: AC/DC

Amperage Recommendations:	AMPS	DIA.
	25-90	1/16"

E6024 - QUICK START

Part No.	Description
1440-0412	1/16" 1 lb.
1440-0413	1/16" 5 lbs.

Maintenance Rod

Mild steel type electrode designed for general purpose. Excellent for low heat applications and best used with a clean or prepared surface. This electrode has a 60,000 PSI tensile strength and can be used on AC or DC, reverse polarity.

Part No.	Description
1440-0454	1/16" 1 lb.

Stainless Steel Electrodes



1440-0165

308 Stainless Steel Electrodes

- For welding all 200 and 300 series stainless up to and including 308
- Provides equal or better corrosion resistance than the base metal
- Can be used for fabricating and repairing austenitic manganese steel

308 STAINLESS STEEL

Part No.	Pack Size	Electrode Description
1440-0165	1 lb. Box	3/32" x 14" Electrodes
1440-0155	1 lb. Box	1/8" x 14" Electrodes
1440-0156	5 lbs. Box	1/8" x 14" Electrodes



1440-0155/1440-0156

E-309L

- For welding/joining of 300 series stainless to mild steel.
- Provides equal or better corrosion resistance than the base metal

Part No.	Pack Size	Electrode Description
1440-0497	1 lb. Box	3/32" x 14" Electrodes
1440-0496	1 lb. Box	1/8" x 14" Electrodes

ELECTRODES, WIRE, & SOLDER

Nickel Base Electrodes

ESt Cast Iron Electrodes (Non-Machinable, Steel Core)



This cast iron electrode is specifically developed for dirty and oil soaked cast iron applications. It is also ideal for heat affected cast iron repairs. This electrode offers the least expensive method of repairing cast iron. Great for repairing castings, transmission housings, etc. Non-Machinable.

Current: AC/DC - DC+ recommended

Amperage Recommendations: 70-125 Amps

CAST IRON

Part No.	Description
1440-0449	1/8" 1 lb.
1440-0443	1/8" 5 lbs.

Tensile strength 62,000 PSI. Elongation 20%

ENiFeCl Nickel 55 Cast Iron Electrodes (Machinable)



The most versatile cast iron electrode. The best solution for repairing cast iron, heavy cast iron sections. The smooth arc characteristics produce strong, sound welds at low amps. Repairs cylinder blocks, exhaust manifold, and machine bases.

Current: AC/DC - DC+ recommended

Amperage Recommendations:	AMPS	DIA.
	70-90	3/32"
	80-120	1/8"

NICKEL 55 CAST IRON

Part No.	Description
1440-0440	3/32" Job pack (3 rods)
1440-0083	1/8" 1 lb.

Tensile strength 70,000 PSI. Elongation 12%

ENiCl Pure Nickel 99% Cast Iron Electrodes (Machinable)



The highest quality nickel electrode available. Welds well in all positions. The high (99%) nickel content has a natural attraction to cast iron giving it superior performance when welding cast iron material. Nickel 99 can be used on cast iron parts that are subject to heating and cooling, such as engine blocks, cylinder heads, exhaust manifolds, etc. Excellent machinability.

Current: AC/DC - DC+ recommended

Amperage Recommendations:	AMPS	DIA.
	70-90	3/32"
	70-110	1/8"

PURE NICKEL 99% CAST IRON

Part No.	Description
1440-0423	3/32" Job pack (5 rods)
1440-0424	1/8" Job pack (3 rods)
1440-0425	1/8" 1 lb.
1440-0374	1/8" 5 lbs.

Tensile strength 55,000 PSI. Elongation 10%

Aluminum Electrodes

E4043 Aluminum Arc Electrodes



This flux coated aluminum electrode is designed to give a weld with strength ductility and corrosion resistance equal to parent metal. Applications include aluminum, sheet metal, plates, castings, tanks and piping. Tensile strength 34,000 PSI. Elongation 18%.

ALUMINUM ARC

Part No.	Description
1440-0419	1/8" 1 lb.
1440-0420	1/8" 5 lbs.

Current: DC+

Amperage Recommendations:	AMPS	DIA.
	70-120	1/8"

Hardfacing Electrodes

Specialty Electrodes - Hardfacing Electrodes



This high quality, all purpose electrode produces outstanding impact and abrasion resistance. The high deposition rate prolongs surface life of new and worn parts. Ideal for repairing all types of agriculture, construction equipment, auger, buckets, concrete mixers, etc.

Amperage Recommendations:	AMPS	DIA.
	110-140	1/8"

HARDFACING ELECTRODES

Part No.	Pack Size	Electrode Description
1440-0080	1 lb. tube	1/8" #35 High Abrasion/Hardfacing
1440-0081	5 lbs. Box	1/8" #35 High Abrasion/Hardfacing

1440-0080/1440-0081

Cutting Electrodes



A special heavy duty coating produces 7000° heat at high-arc velocity. Use this electrode for a fast, low-cost means of cutting cast iron and stainless steel without special equipment.

CUTTING

Part No.	Description
1440-0426	1/8" 1 lb.

Current: AC

ELECTRODES, WIRE, & SOLDER

Mild Steel Solid Wire

ER70S-6 MIG Wire Solid



- Premium AWS CLASS ER70S-6
- For general purpose MIG welding
- Designed to be used on mild steel
- Best used with clean or prepared welding surface
- Requires a shielding gas
- DC reverse polarity

SOLID WIRE

Part No.	Spool Size	Wire Size
1440-0210	2 lbs.	.023"
1440-0211	11 lbs.	.023"
1440-0212	33 lbs.	.023"
1440-0215	2 lbs.	.030"
1440-0216	11 lbs.	.030"
1440-0217	33 lbs.	.030"
1440-0220	2 lbs.	.035"
1440-0221	11 lbs.	.035"
1440-0222	33 lbs.	.035"
1440-0447	33 lbs.	.045"

Stainless Steel Solid Wire

ER 308L MIG Wire Stainless Steel



- Premium AWS CLASS ER308L
- For stainless steel MIG welding
- Best when used with a clean or prepared welding surface
- Requires a shielding gas
- DC reverse polarity

STAINLESS STEEL

Part No.	Spool Size	Wire Size
1440-0245	2 lbs.	.030"
1440-0489	10 lbs.	.030"

Aluminum Solid Wire

ER5356 MIG Wire Aluminum



- For aluminum MIG welding
- Best when used with a clean or prepared welding surface
- Requires a shielding gas
- DC reverse polarity

ALUMINUM

Part No.	Spool Size	Wire Size	AWS Class
1440-0240	1 lb.	.030"	ER 5356
1440-0241	1 lb.	.035"	ER 5356
1440-0445	3 lbs.	.035"	ER 5356
1440-0456	1 lb.	.030"	ER 4043

Flux Cored Wire

E71T-GS Fluxed Cored



- Premium AWS CLASS E 71T-GS
- Also called “Self-Shielding” or “Gasless”
- For general purpose MIG welders
- Designed to be used on mild steel
- Best used with clean or prepared welding surface
- Requires no shielding gas
- DC straight polarity

FLUX CORED WIRE

Part No.	Spool Size	Wire Size
1440-0230	2 lbs.	.030"
1440-0231	10 lbs.	.030"
1440-0235	2 lbs.	.035"
1440-0236	10 lbs.	.035"

Gas Welding Rods



Low carbon steel rod manufactured to the highest quality standards. Copper coating prevents rusting and improves corrosion resistance. A great rod for shop, home, commercial and maintenance repairs. 65,000 PSI tensile strength.

OXYGEN/ACETYLENE MILD STEEL (Copper Coated)

Part No.	Description
1440-0442	1/16" x 18" 5 lbs.

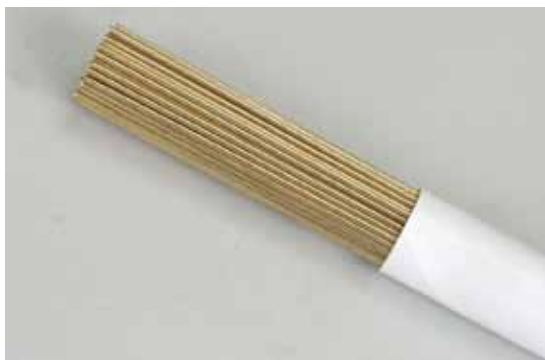

Bare brazing rod low fuming highest quality. Balanced zinc and copper alloy. Excellent for brazing fenders, radiators, water tanks and sheet metal. 63,000 PSI tensile strength.

MANGANESE BRONZE BARE GAS RODS

Part No.	Description
1440-0427	3/32" x 36" 5 lbs.
1440-0428	1/8" x 36" 5 lbs.



Flux coated, low fuming brazing rod. Provides all properties for best tensile strength and ductility. Rod fuses well with cast iron, malleable iron, galvanized iron, steel, brass and copper. 65,000 PSI tensile strength.

MANGANESE BRONZE FLUX COATED GAS RODS

Part No.	Description
1440-0431	3/32" x 36" 1 lb.
1440-0429	3/32" x 36" 5 lbs.
1440-0430	1/8" x 36" 5 lbs.

Brazing & Silverflow Rods



1440-0025

- Lead-free, 0% Silver, 7.1 Phosphorus, balance copper
Known as “poor man’s” silver
- Free flowing/very fluid, no flux required
- Not for ferrous material, use only with copper base alloys
- Use flame torch

SILVERFLOW BRAZING ALLOY

Part No.	Pack Size	Electrode Description
1440-0025	.5 lb. tube	1/16" x 1/8" x 18" long flat rods, 16 pieces per tube



1440-0026

- Low fuming, flux coated bronze, 59%
- For brazing iron based materials (except stainless steel)
- Also used for brazing steel to copper or brass
- Use flame torch

BRONZEFLOW BRAZING ALLOY

Part No.	Pack Size	Electrode Description
1440-0026	.5 lb. tube	3/32" x 18" round rods, 12 pieces per tube



Aluminum rod is excellent for all types of sheet or cast aluminum. This product greatly simplifies the process and requires no flux. Applications include aluminum boats, lawn equipment, outboard motors and castings.

EASY-FLO ALUMINUM BRAZING ROD

Part No.	Description
1440-0434	1/8" x 18" 1 lb.

Solders and Fluxes

Lead Free Solder:

Used for non-electrical applications. Applications include Plumbing and Refrigeration systems. (95% Tin, 5% Antimony)

Lead Free Solder

Part No.	Description	Weight
1423-1115	Lead Free, 95/5	1/8" x 1 lb.
1423-1117	Lead Free, 95/5	1/8" x 1 lb.
1423-1116	Lead Free, 95/5	1/8" x .5 lb.

Acid Flux Core Solder:

Is used for non-electrical applications. Applications include, Sheet Metal joint and fitting connections, works well on many types of metals (Copper, Brass, Nickel and Galvanized Steel).

Acid Flux Core Solder

Part No.	Description	Weight
1423-1102	Acid Flux Core, Comm.	1/8" x 1 lb.
1423-1109	Acid Flux Core, 30/70	1/8" x 1/2 lb.
1423-1108	Acid Flux Core, 40/60	1/8" x 1/4 lb.

Rosin Flux Core Solder:

Used for electrical applications. Completely non-corrosive and electrically non-conductive.

Rosin Flux Core Solder

Part No.	Description	Weight
1423-1114	Rosin Flux Core, 40/60	1/8" x 1 lb.
1423-1113	Rosin Flux Core, 30/70	3/32" x 1/2 lb.
1423-1110	Rosin Flux Core, 40/60	1/16" x 1/4 lb.
1423-1112	Rosin Flux Core, 40/60	3/32" x 1/4 lb.

Soft Silver Solder Kit with Flux

Part No.	Size
1423-1119	1/16" x 36"

Cast Iron, Copper and Brass Brazing Flux

Part No.	Weight
1440-0467	1 lb.

Aluminum Brazing Flux Powder

Part No.	Size
1423-1118	4 oz.

Soldering Flux and Paste

Soft Soldering/Tinning Flux that is active between 200°F and 600°F. Very effective on copper and repairing automotive radiators.

Part No.	Description
1423-1111	2 oz. Soldering Flux
1423-1101	2 oz. Soldering Paste

Anti-Spatter Nozzle Shield

- Prevents spatter adhesion on surface - reduces clean-up time
- Non-flammable - contains no silicones

Part No.	Description
1440-0296	Anti-Spatter Spray, 16 oz.



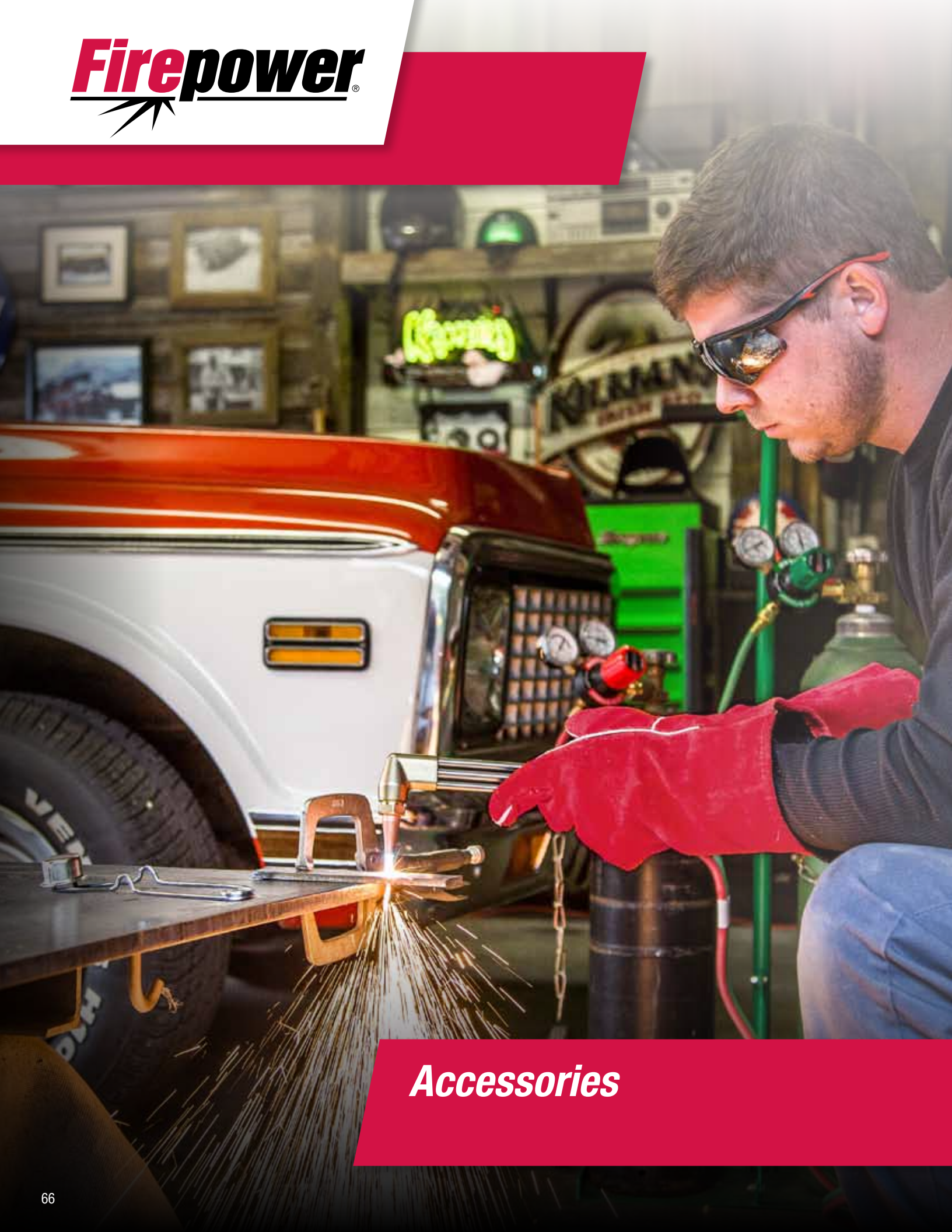

Accessories

Welder's Gloves

Part No. 1423-0051 – Welder's Gloves

- Durable Suede Leather
- Wing Thumb
- Partially Weltded Seams
- Full Sock Lining
- 14" Flared Gauntlet Cuff
- Self Hem
- Size: L



Part No. 1423-4133 – Premium Welder's Glove

- Sturdy Suede Leather
- Wing Thumb
- Fully Weltded Seams
- 100% Cotton Lining
- 14" Flared Gauntlet Cuff
- Self Hem
- Size: L



Welding Protective Blanket and Equipment Cover

Part No. 1423-1404 – Welding Blanket (38" x 24")

- Use our exclusive fabric to protect personnel and equipment during welding, cutting, grinding and other potentially hazardous operations
- Service range up to 1000° F / 538° C, 20% higher than conventional welding fabrics
- Resistant to abrasion
- Fabric can be draped over equipment or used as a curtain to isolate hazardous operations
- Grommets (36"-Centers) for versatility



Welder's Safety and Chemical Splash Goggles

Part No. 1423-0019 – Welder's Cup-Type Goggle, 50mm

- Lightweight, hard plastic goggles (50mm)
- Comes with tough polycarbonate lens (Shade No. 5)
- Adjustable elastic headband and nose piece
- Meets/Exceeds ANSI Z87.1 and various International Standards



Part No. 1423-0017 - Fixed Front, Welders Goggle Soft Frame, 2" x 4.25"

- Furnished with filter lens (Shade No. 5)
- Soft vinyl frame fits easily over corrective glasses
- Hooded vents prevent fogging and offers excellent ventilation
- Adjustable elastic headband
- Meets/Exceeds ANSI Z87.1 and various International Standards



Part No. 1423-0018 – Lift Front, Welder's Goggle Soft Frame, 2" x 4.25"

- Filter lens frame raises easily for on-the-job versatility (Lift Front Type)
- Furnished with filter lens (Shade No. 5)
- Soft vinyl frame fits easily over corrective glasses
- Hooded vents prevent fogging and offers excellent ventilation
- Adjustable elastic headband
- Meets/Exceeds ANSI Z87.1 and various International Standards



Part No. 1423-0020 – Clear Safety Goggle, with Clear Lens

- Furnished with tough polycarbonate clear lens
- For protection against flying particles and dust
- Soft vinyl frame fits snugly and can be worn for extended periods with comfort
- Transparent frame allows vision in all directions
- Hooded vents prevent fogging and offers ventilation
- Adjustable elastic headband
- Meets/Exceeds ANSI Z87.1 and various International Standards



Part No. 1423-4173 – Chemical Splash Goggle, 4 Vents

- Dust, splash and light impact resistant
- Indirect ventilation through four screened vents for added protection
- Clear polycarbonate lens
- Clear frame allows wide angle vision
- Soft vinyl frame fits snugly and can be worn for extended periods with comfort
- Adjustable elastic headband
- Meets/Exceeds ANSI Z87.1 and various International Standards



Grinding Shield

Part No. 1423-4175 – Grinding Shield

- Complete with Clear Visor, 8" x 12" x .040"
- Ratchet quickly adjusts headband to various sizes
- Meets/Exceeds ANSI Z87.1 and various International Standards



Replacement Visors

Part No. 1441-0015 – Replacement Visor

- Clear visor for face shield, 8" x 12" x .040"
- High grade PETG, for excellent protection against paints & mild chemicals
- Wide flare for maximum protection
- Universal hole pattern fits most brand name headgear



Caution: Use PETG visors for protection against lower level impacts only

Safety Glasses

Optimax™ – 58 mm, Safety Glasses

- Meets or Exceeds ANSI Z87.1 and various International Standards

Part No.	Lens Shade
1423-4120	Shade 5



Luxur™ – Fashion Safety Glasses, One-piece Lens, Adjustable Templates

- Meets or Exceeds ANSI Z87.1 and various International Standards

Part No.	Lens Shade
1423-4177	Shade 5



Regal™ – Safety Glasses, 48 mm

- Meets or Exceeds ANSI Z87.1 and various International Standards

Part No.	Lens Shade
1423-4126	Clear
1423-4127	Dark Green



Symetrix™ – Wrap-a Round Visitor Glasses

- Meets or Exceeds ANSI Z87.1 and various International Standards

Part No.	Lens Shade
1441-3408	Symetrix, Clear



Thermal Arc® Auto-Darkening Welding Helmets

Welding Helmet Features

Thermal Arc Professional Auto-Darkening Welding Helmet is designed to meet the needs of the professional user. The helmet offers the latest safety features while providing maximum performance and comfort.

AUTO DARKENING

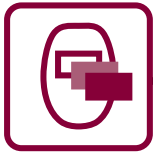

Variable Shade This welding helmet is fitted with an auto-darkening filter lens that has variable adjustment from Shade 9 to Shade 13.

IMPACT RATING



High Impact Rating This welding helmet complies to ANSI Z87.1 high impact requirements (high mass and velocity impact).

WARRANTY



2 Year Warranty This product is manufactured to stringent Thermal Arc quality standards and is covered by a conditional Two Year warranty.

Auto-Darkening Filter Lens features

- Variable shade from 9–13
- Battery powered with solar assist for extended battery life
- 1/20,000 second reaction time
- Fully adjustable sensitivity and delay controls
- Low battery indicator



USA Helmet
Part No. W4011700



Canada Helmet
Part No. W4011800



Black Helmet
Part No. W4012000



Claret Helmet
Part No. W4011900

ACCESSORIES

Part No.	Description	Part No.	Description	Part No.	Description
454332	Helmet Shell, USA	454320	Auto-Darkening Filter Lens	454302TA	Product Bag – Welding Helmet
454333	Helmet Shell, Canada	454299	Rear Cover Lens	454321	Magnifying Lens – 1.00
454334	Helmet Shell, Claret	454330	Cover Lens Holder Button	454322	Magnifying Lens – 1.50
454335	Helmet Shell, Black	454300	Harness Assembly Complete	454323	Magnifying Lens – 2.00
454298TA	Front Cover Lens	454301	Sweat Band	454331	Battery - Type CR2032

NEW Firepower® Auto-Darkening Welding Helmets



Firepower Pinstripes Helmet
Part No. 1441-0085



Firepower Piston & Plug Helmet
Part No. 1441-0086



Firepower Stars & Stripes Helmet
Part No. 1441-0087



Firepower Fire & Skull Helmet
Part No. 1441-0088

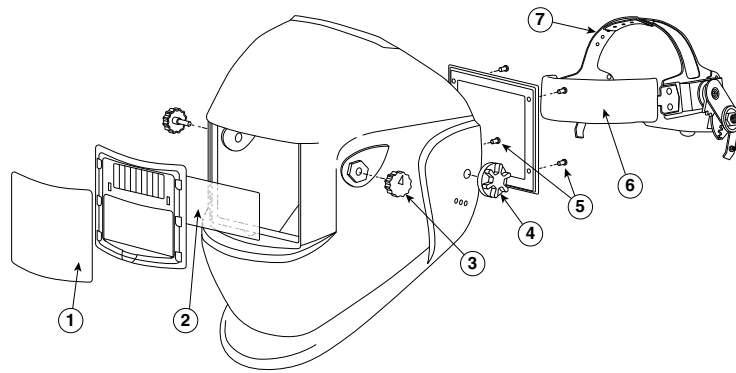

AUTO DARKENING WELDING HELMET SPARE PARTS

Item No.	Part No.	Description	Qty
1	WH41001FL	Front Cover Lens	1
2	WH41001ADF	Auto-darkening filter cartridge	1
3	WH410011L	Inside cover lens	1
4	WH41001KB	Shade knob / Sensitivity knob	1
5	WH41001SN	Shade nut	2
6	WH41001SB	Shade box / Sensitivity box	1
7	WH41001SP	Shade scale plate / Sensitivity scale plate	2
8	WH41001BN	Block nut	2
9	WH41001FHS	Shell, carbon fiber	1
9	WH41001EHS	Shell, eagle	1
9	WH41001CHS	Shell, chopper	1
9	WH41001SHS	Shell, skull & fire	1
10	WH41001FF	Filter setting frame	1
11	WH41001FS	Filter setting screw	4
12	WH41001HB	Front headband	1
13	WH41001LW	Adjustable limitation washer	2
14	WH41001SC	Screw	1
15	WH41001HG	Adjustable headband	1
NS	WH41001HH	Hard hat fixture	1
NS	WH41001ML	Magnifying lens	1

Tweco® WeldSkill® Auto-Darkening Welding Helmets



Tweco Carbon Fiber Helmet
Part No. 4100-1001



Tweco USA Helmet
Part No. 4100-1002



Tweco Flames Helmet
Part No. 4100-1004



Tweco Chopper Helmet
Part No. 4100-1003

Eclipse Welding Helmets

- Extended head, face, neck and ear coverage protects against sparks and slag - preventing burns and harmful Ultra-violet and Infra-red rays
- Channels smoke and fumes away from the welder making breathing easier and unique shape that allows room for respirators
- Built-in magnifier holder is adjustable to multiple positions
- Adaptable to most Auto-darkening Filters
- Helmet includes Shade 10 filter plate and adjustable locking headgear with sweatband
- Meets or Exceeds: ANSI Z87-1 & CE Standards

Part No.	Item
1441-0024	Fixed Front Helmet, 2" x 4.25"
1441-0026	Fixed Front Helmet, 5.25" x 4.5"
1441-0025	Lift Front Helmet, 2" x 4.25"
1441-0059	Auto Darkening Helmet, 2" x 4.25" Fixed Shade #10, 4.9" View
1423-4110*	Headgear for Eclipse™ Helmet

* not shown



1441-0024



1441-0026



1441-0025



1441-0059

Eclipse Welding Helmets

- Streamlined, compact design allows welders to get into tight places
- Meets or Exceeds: ANSI Z87-1, CE and various International Standards

Part No.	Item
1441-0042	Adjustable Ratchet Headgear
1441-0023	Fixed Front Helmet, 2" x 4.25" Economy, Black
1441-0038	Fixed Front Helmet, 4.5" x 5.25" Economy, Black
1441-0004	Lift/Fixed Front Combo Helmet, 4.5" x 5.25", Black
1423-4100	Hand Welding Shield, 2" x 4.25"

1441-0042



1441-0023



1441-0038



1441-0004



1423-4100

Glass Filter Plates

- Hardened glass is heat-treated for strength.
- Meets or Exceeds: ANSI Z87-1, all current applicable Federal Specs., CSA Z94.3, CE and various International Standards.

Part No.	Shade
Filter Plate 2" x 4.25"	
1423-4124	Shade #5
1441-0047	Shade #10
Filter Plate 4.5" x 5.25"	
1441-0049	Shade #10

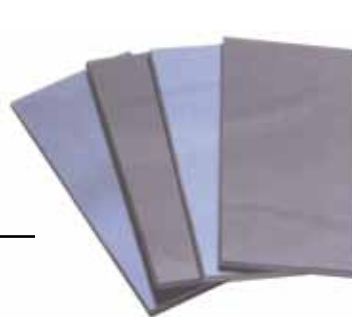

2" x 4-1/4"



4-1/2" x 5-1/4"

Polycarbonate Cover and Safety Plates

- Polycarbonate clear safety or cover plates, as components of welding goggles or helmets exceed the high velocity and high impact requirements of the ANSI Z87.1-1989 and Canadian CSA Z94.3 Standards
- Functions as either cover or safety plate
- Eliminates the accidental use of a cover plate in instances where a safety plate is necessary

Part No.	Size
Polycarbonate Cover/Safety Plate	
1441-0048	2" x 4.25"
1423-4107	2" x 4.25", 3 pc./Pk.
1441-0050	4.5" x 5.25"



1441-0048



1441-0050

Hose Repair Dealer Kit

- Streamlined, compact design allows welders to get into tight places
- Meets or Exceeds: ANSI Z87-1, CE and various International Standards

Part No.	Description
1420-0296	DK-FP; Complete Dealer Kit*

*Includes: "A" and "B" size hose fitting with K12B vise-grip type crimping tool. Contains nuts, nipples, couplers, splicers and ferrules for 1/4" and 3/16" I.D. hose.



Crimper™, Heavy Duty Lug/Splicer Crimping Tool

- Durable spring loaded mechanism holds Terminal/Lug in place
- Delivers 1400-1800 lbs. pull-out resistance (Terminal To Cable)

Part No.	Jaw Opening	Cable Capacity
1423-1209	Up to 1"	6-4/0



Welper® MIG Pliers (8 tools in one!)

- Designed for hammering, wire cutting, insulator bushing removal and installation and drawing out wire
- Perfect for removal and installation of contact tips and nozzles

Part No.	Description
1423-1428	Welper, MIG Pliers

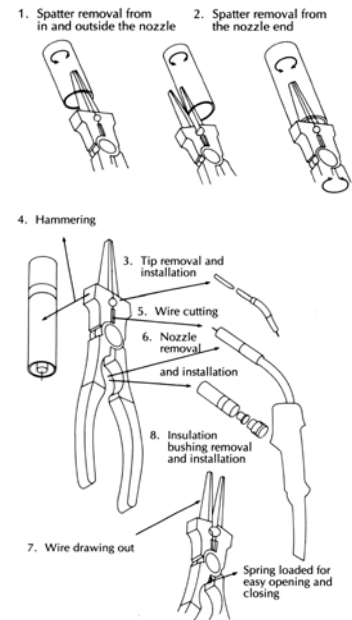

Lightnin' Bug® Torch Lighter

- Tested to 300,000 Strikes !
- Easy and accurate ignition insured by multi-spark discharge
- Zinc Plated body resists rust and corrosion

Part No.	Description
1423-1423	Lightnin' Bug, Torch Lighter



Single Flint, Triple Flint and Flint Replacements

- Tested to 300,000 Strikes !
- Easy and accurate ignition insured by multi-spark discharge
- Zinc Plated body resists rust and corrosion

Part No.	Description
Single Flint	
1423-0026	Single Flint Spark Lighter
1423-0032	Flints for Single Flint Spark Lighter 1 Holder/pk. (5 pcs)
Triple Flint	
1423-0050	Triple Flint Spark Lighter
1423-0052	Flints for Triple Flint Spark Lighter 2 per Pack



1423-0026



1423-0052



1423-0050



1423-0032

Tip Cleaners

Standard

Set of 13 cleaners with file.
 Sizes #6 through #26 for cleaning Drill Size 77-49.

King Size

Set of 13 cleaners Extra Long with file.
 Sizes #6 through #26 for cleaning Drill Size 77-49.



Part No.	Description
1423-0016	Standard Tip Cleaner
0387-0487	King Size Tip Cleaner

Standard

Gage	Wire Dia.	Ridge Dia.	Cleans Hole	
			Diameter Inch	Drill Size
6	0.014	0.016	.018-.020	77-76
7	0.018	0.020	.021-.022	75-74
8	0.021	0.023	.024-.026	73-71
10	0.024	0.026	.028-.031	70-68
12	0.028	0.030	.032-.035	67-65
14	0.032	0.034	.036-.038	64-62
15	0.035	0.038	.039-.040	61-60
16	0.037	0.040	.041-.042	59-58
17	0.039	0.042	.043-.046	57
18	0.042	0.044	.046-.051	56
22	0.048	0.050	.052-.055	55-54
24	0.055	0.057	.060-.064	53-52
26	0.062	0.065	.067-.073	51-49

Tip Drill Cleaner Kit (12 piece)

- Cleans and Trues most Standard Orifices
- Contains most commonly used 12 drills (#57-74) in assorted sizes
- Complete with Built-in Chuck and Pocket Clip

Part No.	Description
1423-1408	Tip Drill Kit, 12 pc. Drill sizes: #52-74



Tip Drill Cleaner

Soapstone

Part No.	Description
1423-0095	Flat Soapstone, 6 pcs./pk
1423-0094	Round Soapstone, 6 pcs./pk



Soapstone Holder

Part No.	Description
1423-0097	Flat Soapstone Holder
1423-0096	Round Soapstone Holder



Handyguard™ , Welding Rod Storage Tube

Weld rod storage tubes provide great storage for all your welding electrodes, rods and filler metals. Chloride-free and features a threaded cap with long lasting neoprene seal to keep electrodes airtight-preventing them from being contaminated with atmospheric moisture.

- Holds up to 10 lbs. of 12" or 14" Electrodes

Part No.	Description
1421-0062	Handy Guard, Weld Rod Storage Tube



Chipping Hammer

- Hammer heads are hardened to precisely controlled temperatures for durability and strength
- Wide-blade design removes slag faster and adds to life of the tool
- Holds up to 10 lbs. of 12" or 14" Electrodes

Part No.	Description	Length	Weight
1423-0086	Cone and Chisel	12"	14 oz.



MasterGage™ Fillet Weld Gage

- High quality stainless steel (SUS 304) blades to resist rust for longer life
- Permits quick and accurate measuring of most popular weld fillet sizes in inches and metric: 1/8"-1" (3.2mm - 25.4mm)
- Set of seven blades come in a handy, vinyl pocket case with snap lock

Part No.	Description
1423-1464	MasterGage, Fillet Weld Gage

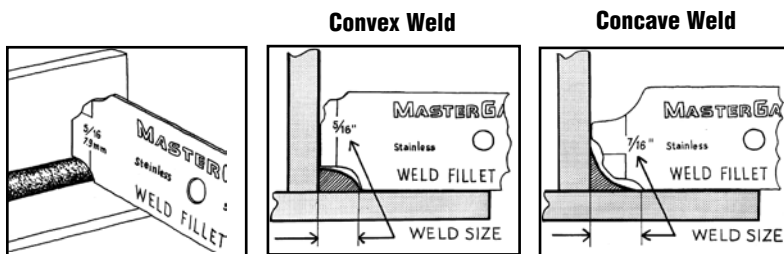

Fillet Weld Gage by MasterGage™

Rap-Around Measuring Tape (For Pipe Measurement)

- An inexpensive tool for marking straight lines around pipe, or for use as a straight edge
- Double-ruled: It's never upside down
- Printed in scale inches, pitch chart, tangent chart and other useful markings
- Packaged in a clear plastic tube for easy identification and protection between jobs

Part No.	Description
1423-1405	Rap-Around Tape, 4" x 72"



4-Way Pick Set

- Knurled 5" aluminum handle
- Four tempered steel picks 3" long – screw into handle

Part No.	Description
1423-1435	4-Way Pick Set



Locking Pliers/Clamps

Part No.	Description
1423-1432	Locking Pliers, 11"



Steel Ground Clamps

- Large contact area assures positive grounding
- Zinc plated
- Large hex screw cable connection assures safe cable connection every time
- Pure copper braided shunts on 1443-0027 allows both jaws to carry welding current

Part No.	Amperage Capacity	Jaw Opening	Cable Capacity	Length
1443-0025	200	Up to 1"	1/0	6"
1443-0026	300	Up to 2"	2-1	8"
1443-0027	500	Up to 2"	1/0-4/0	10"



1443-0025



1443-0026



1443-0027



1443-0002

1443-0003

1443-0004

1443-0005

Cable Lugs

Part No.	Cable Capacity	Amperage	Stud Hole	ID of Socket	Pack
1443-0002	6-8	75	21/64"	10/32"	2 pc./pk.
1443-0003	4-6	100	21/64"	11/32"	2 pc./pk.
1443-0004	6-2	150	17/32"	1/2"	2 pc./pk.
1443-0005	1-2/0	200	17/32"	35/64"	2 pc./pk.

Mag Tool™ Multi-Purpose Magnetic Holders

- Mag Tool will hold both sheet and tube at angles of 45°, 90° and 135°

Part No.	1423-1425	1423-1426
Size	Medium	Large
Dimensions	4.7" x 3.4" x 0.56"	6.3" x 4" x 0.63"

Magnet: Anisotropic Ferrite

** In contact with ferrous objects of adequate thickness and smooth surface finish



1423-1425

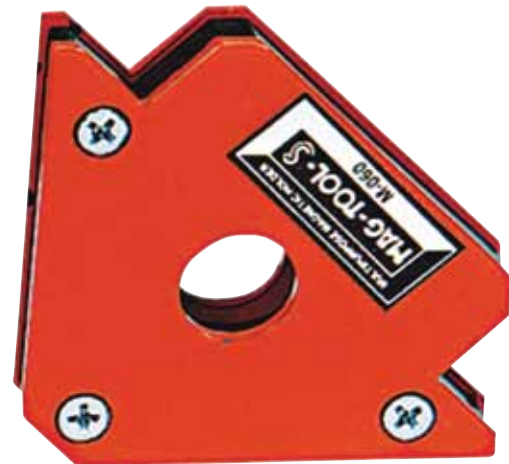

1423-1426

C-Clamps / Malleable Iron

- Steel spindles are copper plated for splatter protection
- Swivel pads adjust freely to bear evenly on clamped parts
- Lacquered Finish

Part No.	Size	Throat Capacity	Depth	Spindle Diameter
1423-1419	4"	0"-4"	2-1/4"	7/16"



Scratch Brushes

Curved Long Handle Brushes

Part No.	Wire	No. of Rows	Trim Length
1423-0087	Carbon Steel	3 x 19	1.1875"
1423-0082	Stainless Steel	3 x 19	1.1875"

Shoe Handle Brushes

Part No.	Wire	No. of Rows	Trim Length
1423-0083	Carbon Steel	4 x 16	1.1875"
1423-1442	Stainless Steel	4 x 16	1.1875"

Welders Toothbrush Style

Part No.	Wire	No. of Rows	Trim Length
1423-0081	Stainless Steel Tinning	3 x 7	1/2"
1423-0084	Brass	3 x 7	1/2"
1423-1400	Brass	2 x 9	1/2"



1423-0081



1423-0084



Flux Brush

Part No.	Trim Width	Trim Length	Total Length	Pack
1423-0093	1/2"	3/4"	5.75"	3 pc./Pk.



Parts Cleaning Brush

Part No.	Handle	Length
1423-1402	Plastic	10.5"



Power Brushes: End Brushes

Firepower® small diameter wire brushes are designed for use in restricted or hard-to-reach areas. They are excellent for deburring, blending and cleaning of surfaces. Small diameter brushes are especially designed for use on portable air and electric tools. Applications include deburring, blending, removal of rust, cleaning. End brushes are great for cylinder heads, pistons and valve ports, rubber and plastic flash removal, removal of rust, paint scale, tool polishing, and weld cleaning.



Part No.	Wheel Diameter	Type	Wire Size	Max. RPM
Circular Type		1/4" Shank		
<i>Carbon Steel Wire</i>				
1423-2100	1.5"	Coarse	.014"	4,500
1423-2101	2"	Coarse	.014"	4,500
1423-2102	3"	Coarse	.014"	4,500
1423-2103	3"	Fine	.008"	4,500
Crimp Type		1/4" Shank		
<i>Carbon Steel Wire</i>				
1423-2104	3/4"	Coarse	.014"	4,500
1423-2117	1"	Coarse	.014"	4,500
Knot Type		1/4" Shank		
<i>Carbon Steel Wire</i>				
1423-2105	3/4"	–	.020"	20,000
1423-2118	1.5"	–	.020"	20,000

Safety First - Always Grind Safely

Warning! Failure to Observe Safety Procedures May Result in Serious Injury:

Complies with Safety Standards of the Industrial Division of the American Brush Manufacturers Association and the American National Standards Institute ANSI B165.1-1985 "Safety Requirements for the Design, Care and Use of Power Driven Brushing Tools".

Always Wear Protective Equipment:

Impact resistant Safety Glasses or Goggles, Full Face Shield, Safety shoes, Arm Guards, Leather Gloves, Apron and other appropriate protective clothing must be worn by all operators and other employees working in the area of power brush operations. Always wear a respirator to avoid inhalation of dust particles.

Machine Guards Must Be Used:

Power brushes should be used only on machines that are equipped with Safety Guards, and they must be in place at all times.

Check Specifications On Mounting Brushes:

Check appropriate RPM before mounting any brush on a power tool. Arbor hole and spindle diameter should be a free fit. Spindle length should be sufficient to accept a full-nut mounting. Direction of spindle nut thread should be opposite to the direction of the spindle rotation so that the nut will tighten as the spindle revolves.

Always Inspect Before Use:

Carefully check all brushes in the original carton. Do Not Use if they are rusty or damaged. Brushes should be stored in the original cartons and should not be exposed to high humidity or other detrimental environmental conditions.

Always Observe Speed Limitations:

Observe all speed restrictions indicated on the brushes, containers, labels, or printed in pertinent literature. For reasons of safety, the "Max. RPM" Must Not be exceeded under any circumstances.

Power Brushes: Wire Cup Type

Firepower® wire cup brushes are designed for use on portable power tools. Made with high quality tempered wire, Firepower brushes provide fast cutting action for removal of light encrustation of scale, rust, paint or weld splatter. The relative high flexibility of fire power wire cup brushes allows cleaning on irregular surfaces as well as flat surfaces.

Cup Brushes with 1/4" Stem: Small diameter cup brushes are designed for use in restricted or hard to reach areas. They are excellent for carbon cleaning, polishing, removal of scale, slag, rust and paint.

Cup Brushes Crimped Wire: Heavy-duty cup brushes with arbor adapters and threads to fit most grinders.

Cup Brushes Stainless Steel Knotted Wire: Heavy-duty cup brushes with arbor adapters and threads for most grinders. Stainless steel wire brushes are used to reduce discoloration and corrosion on stainless and aluminum alloys. Stainless steel wire brushes are highly corrosion resistant and should be used where contamination or after rust is a problem.



1423-2106



1423-3159



1423-2110

Part No.	Cup Diameter	Wire Size	Max. RPM
Crimp Type: Carbon Steel Wire, 1/4" Shank			
1423-2106	1.5"	.014"	4,500
1423-2107	2.5"	.014"	4,500
1423-2108	2.5"	.008" (Fine)	4,500
Crimp Type: Carbon Steel Wire, 5/8" - 11 NC Threaded Arbor			
1423-2109	3"	.014"	12,500
1423-3158	4"	.014"	8,500
Knot Type: Carbon Steel Wire, 3/8" - 24 NF Threaded Arbor			
1423-3159	3"	.020"	12,500
Knot Type: Carbon Steel Wire, 5/8" - 11 NC Threaded Arbor			
1423-2110	3"	.020"	12,500
1423-2115	4"	.020"	8,500
1423-2116	6"	.020"	6,500

Wire Wheel Brushes: Crimped and Knot Style

Firepower® knot-style wire wheel brushes are designed for tough jobs. Each individual knot contains an equal number of top quality high carbon tempered wires, which gives the wheel an exact balance and long-life. Firepower brushes can be furnished in either standard twist in carbon and stainless steel. Firepower brushes are well-suited for use in the welding and fabricating industries. They are used for surface preparation prior to welding and brazing and for removing weld scale and spatter after the welding operation.



1423-2121



1423-2111



1423-2113

Part No.	Wheel Diameter / Width	Wire Size	Arbor Hole	Maximum RPM
<i>Crimped Type: Carbon Steel Wire</i>				
1423-2327	4" dia. x 1/2" wide	.014"	5/8"-11 NC	8,000
1423-2121	6" dia. x 1/2" wide	.014"	5/8"-1/2"	6,000
1423-2122	6" dia. x 1" wide	.014"	5/8"-1/2"	6,000
1423-2123	8" dia. x 1.25" wide	.014"	5/8"-1/2"	4,500
<i>Stringer Bead Carbon and Stainless Steel Wire</i>				
1423-2111	4" dia.	.020"	5/8"-11 NC	12,500
<i>Standard Twist: Carbon and Stainless Steel Wire</i>				
1423-2113	4" dia.	.020"	5/8"-11 NC	12,500
1423-2120	6" dia.	.020"	5/8"-1/2"	9,000

Arbor Reducing Adaptors:

For both cup and wheel brushes - the fixed 5/8"-11 arbor hole of each brush can be adapted to M10 x 1.25, M10 x 1.50 and 3/8-24 NF by using arbor reducing adapter.

- 1423-2124 Arbor Reducing Adaptor, 5/8"-11 to M10 x 1.25
- 1423-2125 Arbor Reducing Adaptor, 5/8"-11 to M10 x 1.5

Steel Rotary Files

- Rotary files offer perfect solutions for the welding jobs: Trimming welds, grinding smooth fillets & preparation for welds
- Repairs can be easily done because of a variety of shapes and sizes available
- All rotary files have a standard shank of 1/4" (6mm)
- Note: use lower speeds when cutting harder ferrous materials and higher speeds for softer non-ferrous materials

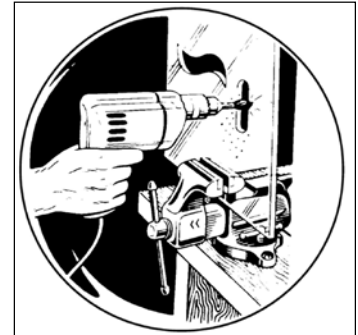

Part No.	Size	Shape
1423-2224	1/2" x 7/8"	Cylindrical
1423-2226	1/2" x 1/2"	Ball



1423-2224



1423-2226

Steel Rotary Rasps

Part No.	Size	Shape
1423-3177	1/2" x 7/8"	Cylindrical



Caution! - Rotary files are for use on electrical power drills only. They are not recommended for use on pneumatic or hydraulic tools.

Abrasive

Specification Example: A-36-S-B-F

Abrasive	Grit	Grade	Bond Type	Reinforcement
A	36	S	B	F

Legend: Select one from each column.				
Abrasive:	Grits	Grades	Bond Types	Reinforcement
A = Aluminum Oxide	Coarse: #16-24	Soft: H, I, J, K	B = Resinoid	1 FG = Inter-woven
C = Silicon Carbide	Medium: #30-60	Medium: L, M, N, O, P	V = Vitrified	2 FG = Double Reinforced
	Fine: #80-220	Hard: Q, R, S, T		

Safety First - Always Grind Safely

Safety: Always DO the following:

1. **Always** handle and store abrasives in a careful manner.
2. **Always** visually inspect all abrasives before mounting for possible damage in transit, storage, or prior use.
3. **Always** "Ring Test" the wheel by tapping gently with a light metallic implement such as the handle of a screwdriver for light wheels, or Wooden or Plastic Mallet for heavier wheels. An undamaged wheel will give a clear tone.
4. **Always** make sure the operating speed established for the equipment **does not exceed** the wheel speed.
5. **Always** check mounting flanges for equal and correct diameter.
6. **Always** use mounting blotters when supplied with abrasives.
7. **Always** keep work rest properly adjusted within 1/8" (3mm) of wheel face.
8. **Always** direct grinding sparks downward and away from the face and body.
9. **Always** wear protective equipment such as, impact resistant safety glasses or goggles, full face shield, safety shoes, arm guards, leather gloves and apron must be used for operator protection for all grinding operations. Always wear a respirator to avoid inhalation of dust particles.
10. **Always** use a safety guard covering at least one-half of the wheel diameter.
11. **Always** allow newly mounted wheels to run at operating speed, with the guard in place, for at least one minute before starting to grind.
12. **Always** observe all safety recommendations supplied by the Equipment Manufacturer.

DO NOT attempt the following:

1. **Do Not** use a wheel that has been dropped.
2. **Do Not** use wheels that have been soaked in water
3. **Do Not** use wheels without guards for grinding or cutoff work.
4. **Do Not** force a wheel onto the spindle or alter the hole of size the wheel.
5. **Do Not** use a wheel that fits the arbor too loosely.
6. **Do Not** exceed maximum operation speed established for the wheel.
7. **Do Not** use dirty, nicked, warped or sprung mounting flanges.
8. **Do Not** tighten the mounting nut excessively.
9. **Do Not** grind on the side of the wheel unless the wheel is specifically designed for that purpose.
10. **Do Not** start machine unless the machine guard is in place.
11. **Do Not** jam work into the wheel. Let the wheel do the work.
12. **Do Not** apply excessive pressure.
13. **Do Not** stand directly in front of a grinding wheel whenever a grinder is started.
14. **Do Not** grind near flammable material.
15. **Do Not** grind or cut material for which the wheel is not designed.
16. **Do Not** flat grind. Minimum grinding angle is 15°.
17. **Do Not** use relieved or recessed flanges with threaded hole cup wheels, cone or plugs.
18. **Never** use a wheel or a disc that has been dropped, chipped, mishandled or appears defective.

Depressed Center Grinding Wheels, Type 27

Firepower® depressed center wheels are fully reinforced with resin bonded aluminum oxide to ensure safety at high speed and to increase bonding and impact strength. Designed for use on air or electric powered right angle or vertical shaft grinders. Available with or without hubs.



Part No.	Size	Max. RPM	Grade
Without Hubs:			
1423-3151	4" x 1/8" x 5/8"	13,700	A36S
1423-2186	4" x 1/8" x 5/8" (5 pc./Pk)	13,700	A36S
1423-3152	4" x 1/4" x 5/8"	13,700	A24R
1423-2187	4" x 1/4" x 5/8" (5 pc./Pk)	13,700	A24R
1423-3186	4.5" x .045" x 7/8"	13,300	A36S
1423-3199	4.5" x 1/8" x 7/8"	13,300	A36S
1423-3153	4.5" x 1/4" x 7/8"	13,300	A36S
1423-2188	4.5" x 1/4" x 7/8" (5 pc./Pk)	13,300	A24R
1423-2189	5" x 1/4" x 7/8"	12,000	A24R
1423-2191	7" x 1/4" x 7/8"	8,500	A24R
With Hubs:			
1423-3201	4.5" x 1/8" x 5/8"-11 NC	13,300	A24R
1423-2232	4.5" x 1/4" x 5/8"-11 NC	13,300	A24R
1423-3203	7" x 1/8" x 5/8"-11 NC	8,500	A24S
1423-2190	7" x 1/4" x 5/8"-11 NC	8,500	A24S
1423-2192	9" x 1/4" x 5/8"-11 NC	6,500	A24S

Techniques/Tips for proper Firepower Grinding Wheels:

1. Use this method to achieve the desired aggressiveness of stock removal and quality finish - for fast material removal increase the grinding angle between the wheel and the workpiece. For blending and finishing decrease the grinding angle and apply light pressure in a fluid motion.
2. For maximum efficiency, Type 27 Depressed Center Wheels should be used with a approach angle of 30°-35° to the workpiece.
3. Material being cut or ground should always be clamped or securely positioned, especially in cutting-off operations.
4. Proper machine speed is essential for maximum efficiency. Low speed causes "Jumping" of the disc, and can cause the circumference to wear unevenly.
5. Only flat cut-off wheels can be brushed, not depressed center wheels. Only 7/8" arbors can be made to 5/8"-11.

Cut-Off Abrasive Wheels, Type 1 (For Metal)

Firepower® Double Reinforced Cut-Off Wheels are designed for heavy duty cut-off jobs using circular saws, chop-saws and straight grinding machines. They ensure optimum effectiveness for dry applications on a broad range of ferrous and non-ferrous metals, soft ceramics, masonry materials, reinforced plastic and fiber glass. Most Firepower cut-off wheels are double reinforced with two layers of fiber glass.



Part No.	Size	Max. RPM	Grade
Type 1, Abrasive Cut-Off Wheels:			
1423-3149	3" x 1/32" x 3/8"	25,000	A60T2FG
1423-3181	3" x 1/32" x 3/8" (5 pc./Pk)	25,000	A60T2FG
1423-3142	3" x 1/16" x 1/4"	25,000	A46T2FG
1423-3143	3" x 1/16" x 3/8"	25,000	A46T2FG
1423-3155	3" x 1/16" x 3/8" (5 pc./Pk)	25,000	A46T2FG
1423-2178	3" x 1/16" x 3/8" (10 pc./Pk)	25,000	A46T2FG
1423-3208	3" x 1/8" x 1/4"	25,000	A46T2FG
1423-3144	3" x 1/8" x 3/8"	25,000	A46T2FG
1423-2180	3" x 1/8" x 3/8" (5 pc./Pk)	25,000	A46T2FG
1423-3150	4" x 1/32" x 3/8"	18,000	A60T2FG
1423-3182	4" x 1/32" x 3/8" (5 pc./Pk)	18,000	A60T2FG
1423-3145	4" x 1/16" x 3/8"	18,000	A46T2FG
1423-3147	4" x 1/16" x 5/8"	18,000	A46T2FG
1423-3157	4" x 1/16" x 5/8" (5 pc./Pk)	18,000	A46T2FG
1423-3146	4" x 1/8" x 3/8"	18,000	A46T2FG
1423-3148	4.5" x 1/16" x 7/8"	13,300	A46T2FG
1423-3184	4.5" x 1/16" x 7/8" (5 pc./Pk)	13,300	A46T2FG
1423-3185	4.5" x 1/8" x 7/8"	13,300	A46T2FG
1423-3188	6" x .045" x 7/8"	10,200	A60T2FG
1423-3211	6" x 1/16" x 5/8"	10,200	A60T2FG

Use Tips for Firepower Cut-Off Wheels:

- When using cut-off wheels, a soft pressure should be used for initial contact with the workpiece - cutting should be done with even constant pressure.
- For stationary cut-off machinery, it is important to have good stability and steadiness to prevent vibration. Also, the motor should be powerful enough to keep the cutting time as short as possible to prevent burning or discoloring the material
- Material being cut or ground should always be clamped or securely positioned, especially in cutting-off operations.
- Proper machine speed is essential for maximum efficiency. Low speed causes "Jumping" of the disc, and can cause the circumference to wear unevenly.
- Flat cut-off wheels can be brushed, if required.

Cut-Off and Chop-Saw Abrasive Wheels, Type 1 (for metal)

- Single reinforced cut-off wheels are recommended for stationary Chop-Saws only
- 7" (175mm) diameter wheels are equipped with Diamond Center hole for easy-mounting on portable circular saws



Part No.	Size	Max. RPM	Grade
Large - Type 1, Abrasive Cut-Off Wheels:			
1423-2213	7" x 1/8" x 5/8" Diamond Hole	8,500	A36S 2FG
For Stationary Chop-Saws Only:			
1423-2305	10" x 1/8" x 5/8"	6,100	A36S 2FG
1423-3189	10" x 3/32" x 1"	6,100	A46S 1FG
1423-2197	12" x 3/32" x 1"	5,100	A46S 1FG
1423-2198	14" x 3/32" x 1"	4,400	A46S 1FG
For Portable High Speed Chop-Saws:			
1423-3191	12" x 5/32" x 1"	6,300	A36S 2.5FG
1423-3193	14" x 5/32" x 1"	5,400	A36S 2.5FG

Firepower® Cut-Off Wheel Safety and Cutting Procedures:

1. Cut-off wheels should never be stored on edges. They should be laid on a solid flat surface and away from excessive heat to prevent warpage.
2. Machines must have adequate power transmission and capacity, spindle speeds and proper guarding of the wheel. It is best to have extra power to insure good cutting efficiency. Check the speed of the machine spindle against the maximum speed specified for the wheel by the manufacturer. The maximum specified speed for the wheel should never be exceeded.
3. Flanges should be clean, straight and of the same diameter, so the wheel can turn true. For wheel diameters above 10" (250mm) it is highly recommended that the flange be at least 1/3 the diameter of the wheel.
4. The bore size of the wheel is so constructed that the wheel should fit freely on the machine spindle without any slack. Never attempt to force a wheel on the spindle! Always use blotters, when supplied with the wheel. Be sure the flanges are tightened securely but not too tightly to avoid springing the flanges and change the pressure area.
5. Be sure work-piece is securely held down, including both sides of the cut, if practical. Cut-off wheels withstand a great deal of radial stress but not any side stress. Even reinforced wheels are not completely unbreakable. Side pressure must be avoided to insure straight cuts and avoid possible wheel breakage. The wheel must be brought into contact with the work without "Bumping" or impact. The wheel should cut freely without forcing and the speed of the wheel should not be reduced by the cutting operation.
6. Abrasive cutting generates a great deal of localized heat, which causes rapid expansion of the piece being cut. Wheels operated at speeds significantly below efficient speed or if fed through the cut too slowly will generate excessive heat. Result: rapid wheel wear, fraying around the edge of reinforced wheels and wheel breakage. Always use at the "efficient speed" as specified for the wheel by the manufacturer.

Mandrel Set

- Made of high strength alloy steel
- Ideal for small diameter cut-off wheels with a thickness of 1/32" to 1/4"

Part No.	Size
1423-2185	For 1/4" & 3/8" Arbors, with 1/4" Shank

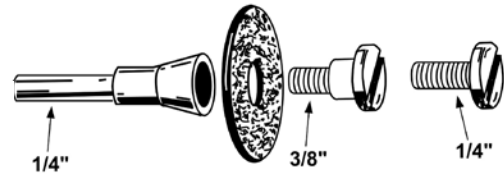

Mounting Points

- Offer maximum performance for grinding of ferrous and non-ferrous metals. For use with horizontal or straight shaft, die and pencil grinders on jobs where larger cones and plugs won't fit
- Excellent for medium to heavy duty applications in metal fabrication, foundries, steel mills. Used for grinding ferrous and non-ferrous metals
- Ideal for rapid stock removal on high alloy steel, castings and special steel

Part No.	Type & Shape	Size (Dia. x Length x Shank)	Max. RPM
1423-2202	A11	7/8" x 2.75" x 1/4"	19,000



Bench Grinding Wheels, Type 1

- Wheels are individually precision balanced, trued and faced for smooth operation
- Each wheel is individually boxed so they stay clean and undamaged until use
- Designed for versatile off-hand grinding in deburring barstock after cutting and touching up, reconditioning and sharpening tools where precision grinding is not required
- Grinding is done on the wheel periphery only
- Aluminum oxide wheel grinds metal of high tensile strength, like steel and steel alloy

Part No.	Size	Grit
1423-2311	6" x 3/4"	36
1423-2310	6" x 3/4"	60
1423-2312	6" x 3/4"	80

1423-2310



Safety First - Always Grind Safely!

Always ensure grinding wheels and machines are in good working condition. Damaged or improperly used grinding wheels are dangerous. Machine guards are for protection - use them. Wear adequate personal protection. All Firepower® abrasives are manufactured under rigid quality conditions to ensure product strength and safety. However, approved guards and protective equipment, such as, impact resistant safety glasses, full face shield, safety shoes, arm guards, leather gloves and apron must be used for operator protection for all grinding operations. Always wear a respirator to avoid inhalation of dust particles. For information on product safety, please ask us for ANSI B7.1 "Safety Requirements for the use, Care and Protection of Abrasive Wheels".

Flap Discs Zirconia, Type 29

Firepower® flap discs durability over the conventional fibre disc results in reduction of both labor and material costs. They are designed to wear away evenly and present a constantly fresh working surface.

- Cut and finish at the same time with consistent finish - for coarse and intermediate grinding and machining of welds, deburring, rust removal, snagging, removal of paint, etc. This means fewer change-overs
- Suitable for almost all materials: ferrous and non-ferrous metals, wood, leather, glass, marble and plastics
- No loading-up, as new sharp abrasive particles are constantly exposed
- No backing pad required - comes with fiberglass backing plate with higher RPM rating than resin fiber discs



1423-3162

Recommendation:

- We recommend using the following grit sizes to attain a maximum stock removal rate
 - Grit 36*: For all alloyed and low-alloyed steels
 - Grits 60 & 80*: For high alloyed steel, stainless steel, high-temperature and heat treatable steel and high tensile, non-ferrous metals
- * A coarser grit offers the advantage of a higher stock removal rate and service life
- Firepower flap discs have the ideal operating angle of 10°. This allows for maximum use of the laminates and guarantees optimum stock removal produced by a continuously free cutting abrasive.
- Excessive pressure leads to a higher wheel-wear, without increasing performance



Part No.	Grit
4.5" x 7/8" (without Hub):	
Max RPM: 13,300	
1423-3162	ZA 36
1423-3163	ZA 60
1423-3164	ZA 80
4.5" x 5/8"-11 NC (with Hub):	
Max RPM: 13,300	
1423-2220	ZA 36
1423-2221	ZA 60

Safety First - Always Grind Safely!

To avoid injury always wear impact-resistant protective glasses, full face shield, safety shoes, arm guards, leather gloves and apron for all grinding operations.

For Abrasive Disc Grinding:

1. Never use a larger diameter disc than specified by manufacturer
2. Never exceed maximum RPM
3. Check for concentricity
4. Always check for snug fit and full-thread contact
5. Always use grinders safety pad
6. Always check spindle for wobble
7. Always check disc retainer nut for thread wear

Resin Fiber Sanding Disks and Hand Pads

Firepower® resin fibre discs have the best combination of the highest quality aluminum oxide grains and heavy-duty vulcanized fibre-cloth backing bonded with strong, heat resistant resin

- Excellent for removing rust, oxides and surface imperfections
- Maximum performance on portable right angle grinders
- Firepower resin fibre discs should be mounted on a rubber backing pad, for optimum performance



Part No.	Grit
----------	------

5" x 7/8" (3 Pc./Pack):

Max RPM: 11,000

1423-2164	A.C 24
1423-2165	A.C 36
1423-2166	A.C 50

7" x 7/8" (3 Pc./Pack):

Max RPM: 7,600

1423-2171	A.C 24
1423-2172	A.C 36
1423-2173	A.C 50

Safety First - Always Grind Safely!

To avoid injury always wear complete body protection at all times: Impact-resistant protective glasses, full face shield, safety shield, safety shoes, arm guards, leather gloves and apron for all grinding operations. Always wear a respirator to avoid inhalation of dust particles. Persons entering an area where grinding is taking place, must always wear adequate and approved face and body protection.

For Abrasive Disc Grinding:

1. Never grind without a proper back-up pad
2. Never use larger diameter disc than specified by the manufacturer
3. Never use back pad without first inspecting it for signs of irregularities such as fractures, excessive wear, nicks, cuts at the edges or the centre hole.
4. Always check the pad for concentricity. Always check the grinder spindle for wobble. Always check the disc retainer nut for thread wear. Install the pad on the tool securely. Check for snug fit and three thread contact.
5. Direct grinding sparks downward and away from the face and body. Do Not Grind near any flammable material.
6. Never use another grinding disc as a back-up pad.
7. Never exceed maximum RPM.
8. Always use the grinders safety pad.
9. Operate grinder with disc and pad inclined approximately 5°-15° from the work surface. Grind depressions, moulding, lips and heavy welds with the grinder moving away from the work area and not into it. Avoid grinding near the edge, corner or projections that can snag the edge of the pad or disc.
10. Always observe all safety recommendations supplied by the equipment manufacturer.

Quick Change and Surface Conditioning Discs, Type III

- Provide low vibration, less tool down time, and longer disc life
- Designed for quick disc and grit changes
- These time saving discs are quickly and firmly mounted on a special reusable 1/4" mandrel
- Surface conditioning discs provide superior performance for: Scratch removal, Removing flash, rust and oxidation, light deburring, blending welds, blending and conditioning metal surfaces and removing heat discoloration
- Maximum RPM: 5,000

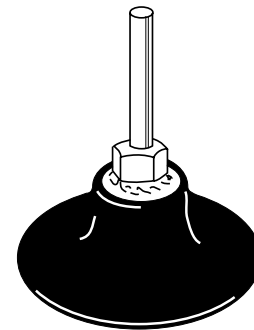
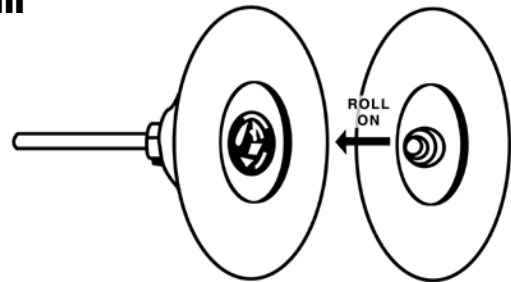

Part No.	Grit/Color	Type	Pcs./Pk.
1423-2140	Brown	Coarse	10
1423-2141	Maroon	Medium	10

Surface Condition Discs, 3"

1423-2143	3" x 1/4" Shank
-----------	--------------------



Mounted Flap Wheels

Firepower® flap wheels are constructed of hundreds of resin bonded cloth abrasive sheets firmly attached to a balanced core. During use, each flexible sheet adapts quickly to the contours of the workpiece - continuously exposing fresh, sharp grit for extended product life. The controllable aggressiveness, working speed, and low cost of the wheels make them superior to wire brush, grit-impregnated plastic, fibrous and setup wheels in a wide range of applications.

Part No.	Wheel Dimensions	Grit	Max. RPM
Mounted Flap Wheels			
1423-2160	1" x 1" x 1/4"	60	25,000
1423-2161	1" x 1" x 1/4"	80	25,000
1423-2157	1.5" x 1/2" x 1/4"	60	25,000
1423-2158	1.5" x 1/2" x 1/4"	80	25,000
1423-2254	1.5" x 1/2" x 1/4" (5 pc./Pack)	80	25,000
1423-2255	1.5" x 1/2" x 1/4" (5 pc./Pack)	120	25,000
1423-2151	3" x 1" x 1/4"	60	18,000
1423-2152	3" x 1" x 1/4"	80	18,000



1423-2152



1423-2158



1423-2160

Tips for Firepower Abrasive Flap Wheels:

1. Make sure flap wheel is run in correct direction of rotation. For automatic in-feeding of workpiece, the direction of flap wheel rotation should be contrary to the feed direction.
2. For a given finish, choose a grit one or two sizes coarser compared to abrasive belts.
3. Coarse grit sizes used at high speeds work finer. Fine grit sizes used at lower speeds work coarser.
4. Grinding oil or grease may be used for improved finish and the flap wheel life.
5. Use light pressure at low speeds, added pressure at high speeds. Do Not use excessive pressure or allow the flaps to bend back to far. If more stock removal is necessary, choose a coarser grit.
6. Abrasive flap wheels can be shaped to fit contours and other configurations by using a file, abrasive stone, or other cutting tool to cut the mop face. Always use proper safety equipment.
7. Make sure that mounting plates are of the proper size and are correctly fitted when used. Never over tighten fastening nuts or hub damage may result. Always use proper machine guards.