

DESCRIPTION: AIR POWERED HORN

FULTONE

Part Number: 6235112

Main specifications and performances

Sound pressure level	117 (2m)	dB(A)
Frequency 'L'	260	Hz
Frequency 'H'	300	Hz
Working pressure	500 - 1200	kPa
Air consumption	0,9	l/sec
Operating temperature	-30° to +80°	°C
Storage temperature	-30° to +80°	°C
Corrosion resistance	> 600 (salt spray test)	Hours
Operating relative humidity	30 to 80	%
Durability (1 sec ON, 4 sec OFF)	>50 000	Cycles
Continuous blowing	60	min
Vibration (30 min, 3 axis)	1	g
Weight / Peso	900	gr
Main Materials	Stainless Steel, Aluminum	
Main applications	Trucks	

Dimensions (mm)

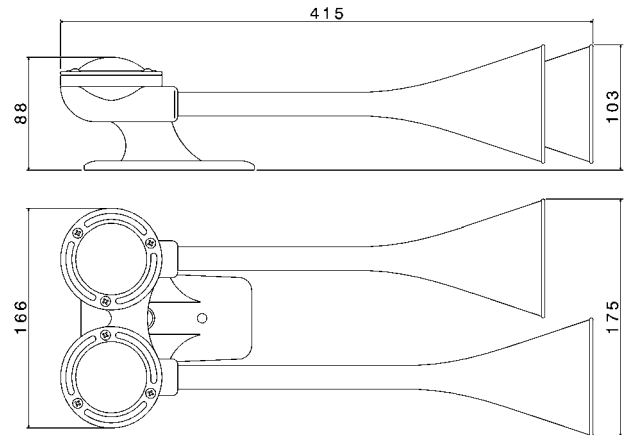

Pneumatic connection

Threaded hole 1/8 GAS

Other specifications

Mechanical connection: flat and rigid surface

Horn's Protection: choose an installation area protected from mud splash

Packaging: Color box 135 x 480 x h200 mm

Master carton: 6 pieces

Conformity to Standards of

PRODUCT

- ✓ CEE 70/388
- ✓ REG. 28 ECE

MANUFACTURING

- ✓ ISO/TS 16949
- ✓ ISO 9001
- ✓ ISO 14001

Product and packaging

