

DESCRIPTION: ELECTROMAGNETIC HORN – HIGH TONE

HK9/H

PN: 5222012

Main specifications and performances

Nominal voltage	12	Vdc
Voltage range	11,5-13,8	Vdc
Current consumption	3	A
Sound pressure level	110 (2m)	dB(A)
Frequency 'H'	425	Hz
Operating temperature	-30° to +80°	°C
Storage temperature	-30° to +80°	°C
Corrosion resistance	> 480 (salt spray test)	Hours
Operating relative humidity	30 to 80	%
Durability (1 sec ON, 4 sec OFF)	>50 000	Cycles
Continuous blowing	> 3	min
Electrical insulation	1000	Vdc
Vibration (30 min, 3 axis)	1	g
Weight	270	gr
Main materials	Steel, Aluminum	
Main applications	Trucks, Industrial vehicles	

Dimensions (mm)

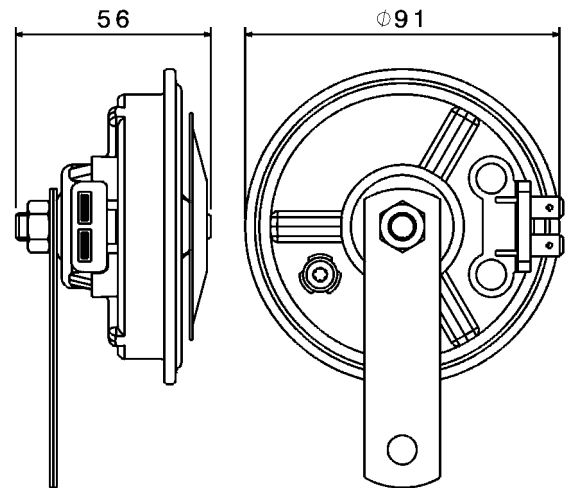

Available Electrical Connection

Two Terminals 6,3x0,8 mm

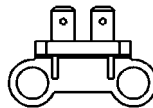

Other specifications

Mechanical connection: flat and rigid surface facing the bracket edge

Horn's Protection: choose an installation area protected from direct water and mud splash

Packaging: color box 82 x 90 x h105 mm

Master carton: 35 pieces

Conformity to Standards of

PRODUCT

- ✓ CEE 70/388
- ✓ REG. 28 ECE
- ✓ REG.10 ECE

MANUFACTURING

- ✓ ISO/TS 16949
- ✓ ISO 9001
- ✓ ISO 14001

Product and packaging

