

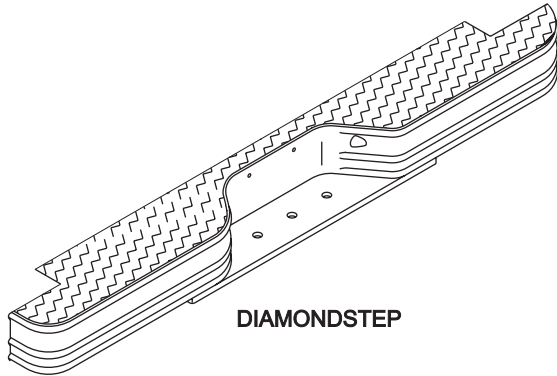

INSTALLATION INSTRUCTIONS

APPLICATION: 1983 - 2003 CHEVY S-10/S-15/SONOMA
 1982 - UP FORD RANGER
 1994 - UP MAZDA PICKUP

MOUNT KIT: #72/97200



DIAMONDSTEP

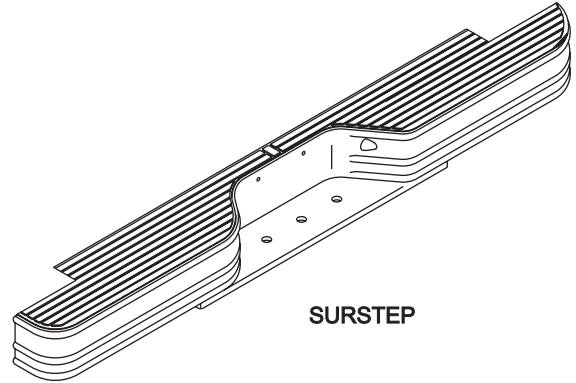

SURSTEP

BUMPER WIDTH: 61.50"
 HITCH WIDTH: CHEVY 40.50"
 HITCH WIDTH: FORD 33.00"
 VEHICLE FRAME WIDTH: CHEVY 40.50"
 VEHICLE FRAME WIDTH: FORD 33.00"

QTY	MOUNTING KIT CONTENTS	BUMPER KIT CONTENTS	TOOLS REQUIRED
1	DRIVER SIDE MOUNTING BRKT	1 BUMPER	5/8" SOCKET
1	PASSENGER SIDE MOUNTING BRKT	1 LICENSE PLATE LIGHT KIT	11/16" WRENCH
8	1/2" HEX BOLT		3/4" SOCKET
8	1/2" SPLIT LOCK WASHER		3/4" WRENCH
8	1/2" FLAT WASHER		RATCHET
8	1/2" NUT		TORQUE WRENCH
4	7/16" HEX BOLT		
4	7/16" SPLIT LOCK WASHER		
4	7/16" FLAT WASHER		
4	7/16" NUT		

CHEVY S-10/S-15 SONOMA 1983 - 2003

- STEP 1: USING 7/16 INCH HARDWARE, LOOSELY INSTALL MOUNTING BRACKET ON THE OUTSIDE OF TRUCK FRAME RAILS. (SEE FIGURE 1). DO NOT TIGHTEN MOUNTING HARDWARE.
- STEP 2: USING OUTER HITCH VERTICALS, INSTALL BUMPER ONTO MOUNTING BRACKETS. (SEE FIGURE 1). DO NOT TIGHTEN MOUNTING HARDWARE.
- STEP 3: POSITION BUMPER SQUARELY TO TAILGATE AND ALLOW CLEARANCE FOR TAILGATE TO OPEN. TIGHTEN HARDWARE AS FOLLOWS: 7/16" TO 45-50 ft-lbs.

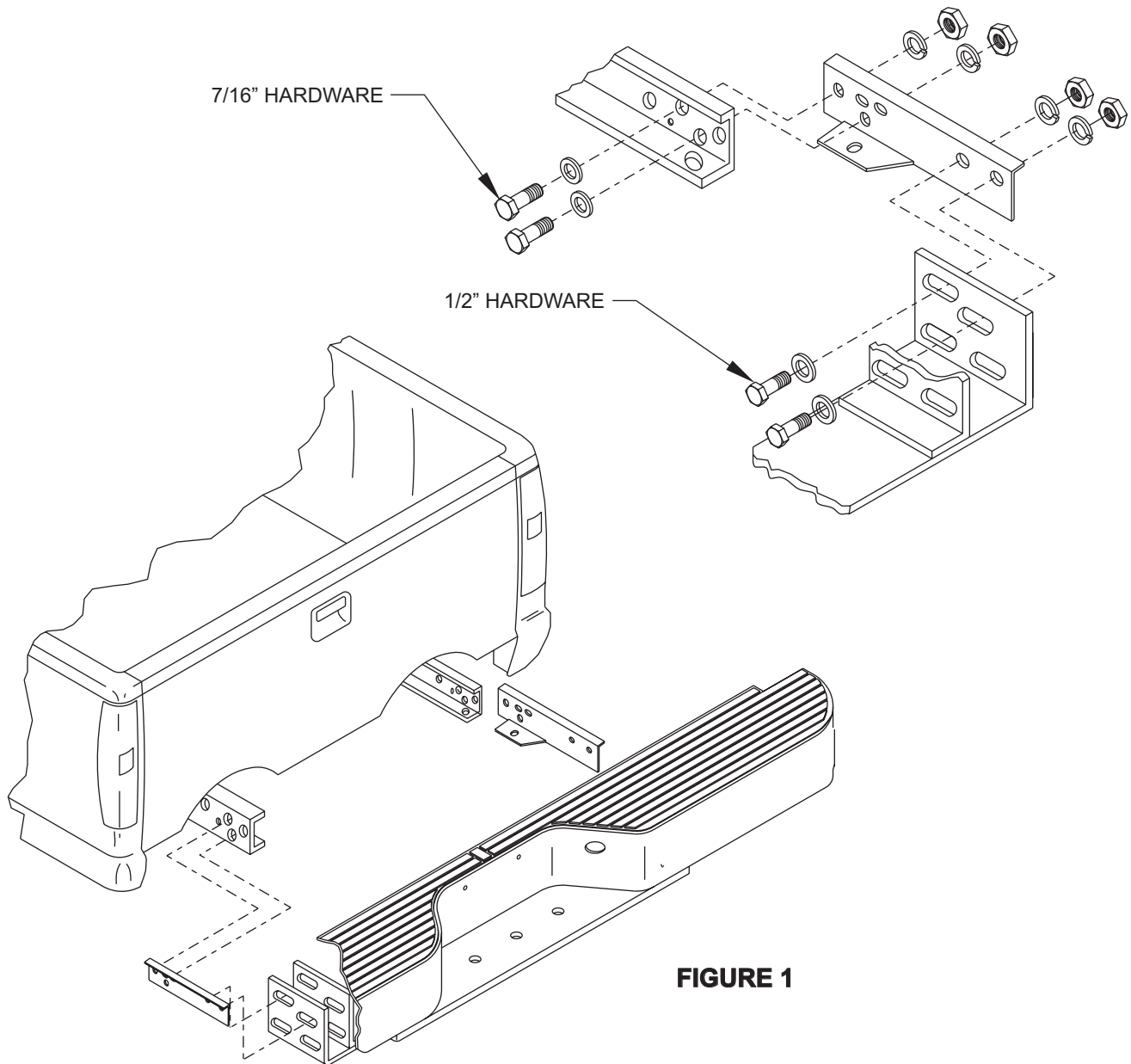

FIGURE 1

FORD RANGER 1982 - UP MAZDA 1994 - UP

- STEP 1: USING 1/2 INCH HARDWARE, LOOSELY INSTALL MOUNTING BRACKET ON THE OUTSIDE OF TRUCK FRAME RAILS. (SEE FIGURE 2). DO NOT TIGHTEN MOUNTING HARDWARE.
- STEP 2: USING INNER HITCH VERTICALS, INSTALL BUMPER ONTO MOUNTING BRACKETS OUTSIDE OF BUMPER HITCH. (SEE FIGURE 2). USE REMAINING 1/2 INCH HARDWARE. DO NOT TIGHTEN.
- STEP 3: POSITION BUMPER SQUARELY TO TAILGATE AND ALLOW CLEARANCE FOR TAILGATE TO OPEN. TIGHTEN HARDWARE AS FOLLOWS: 1/2 TO 60-65 ft-lbs.

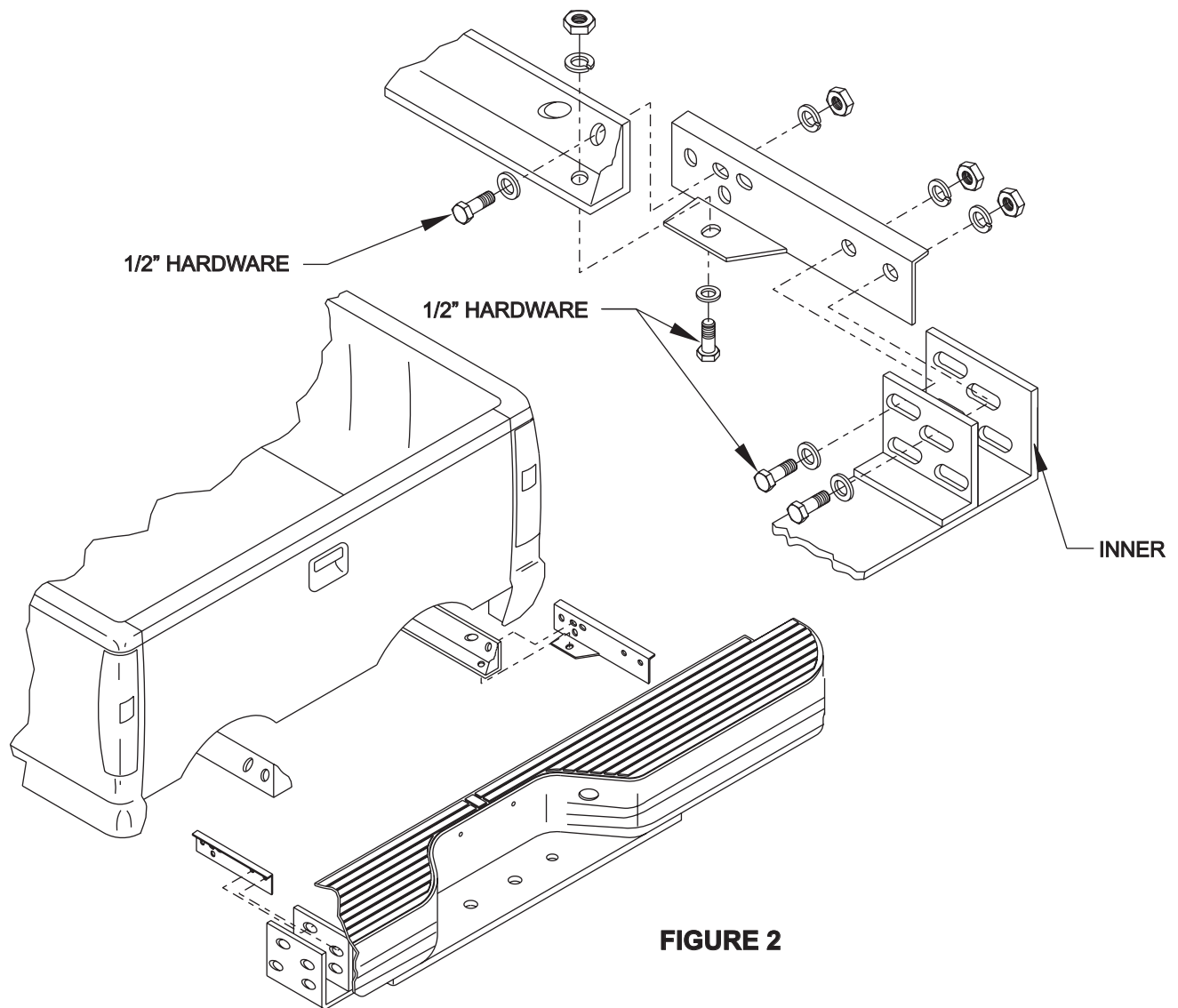

FIGURE 2

STEP 1: USING SQUARE PLASTIC GROMMETS AND SHEET METAL SCREWS, INSTALL LICENSE PLATE. (SEE FIGURE 3).

STEP 2: INSTALL POP LIGHTS INTO BUMPER (SEE FIGURE 4). USING SUPPLIED. CONNECTORS, SPLICE POP LIGHT WIRES INTO TRUCK ILLUMINATION WIRE AS SHOWN IN (SEE FIGURE 4). VERIFY THAT LICENSE PLATE LIGHTS ARE WORKING PROPERLY.

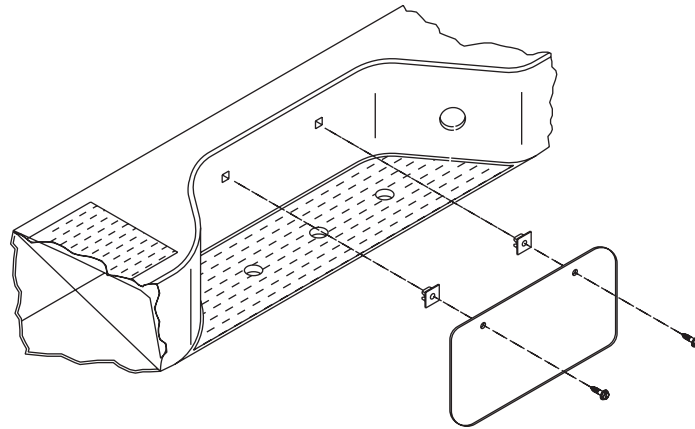

FIGURE 3

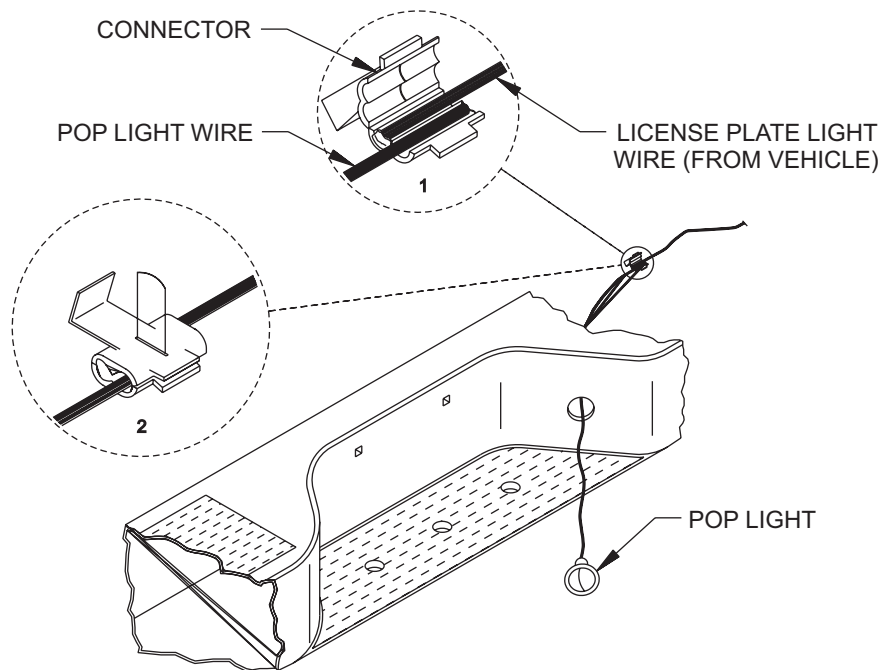

FIGURE 4