



INSTALLATION INSTRUCTIONS

APPLICATION: 1988-1998 CHEVY/GMC 1500 F/S TRUCK
1988 - 2000 CHEVY/GMC 2500 & 3500 F/S TRUCK

BUMPER WIDTH: 74.50
HITCH WIDTH: 37.25
VEHICLE FRAME WIDTH: 37.06

BUMPER KIT : 31000 CHROME
: 32000 BLACK
: *31100 CHROME W/O OUTER BRACKET
: *32100 BLACK W/O OUTER BRACKET

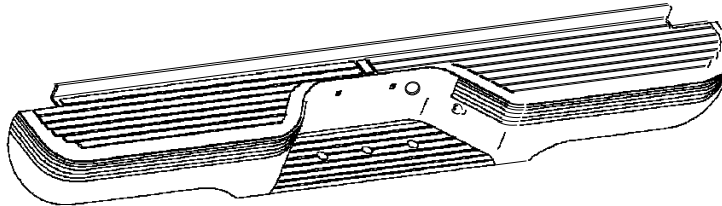

PERFECT MATCH BUMPER

* (NOT INCLUDED IN 31100 & 32100)

QTY	MOUNTING KIT CONTENTS	BUMPER KIT CONTENTS	TOOLS REQUIRED
1	MOUNTING BRACKET, DRIVER SIDE, OUTER*	1 BUMPER 1 LICENSE PLATE MOUNT LIGHT KIT #887153	9/16 INCH SOCKET 9/16 INCH WRENCH 15mm SOCKET 15mm WRENCH 3/4 INCH SOCKET 3/4 INCH WRENCH RATCHET TORQUE WRENCH
1	MOUNTING BRACKET, DRIVER SIDE, INNER*		
1	MOUNTING BRACKET, PASSENGER SIDE, OUTER		
1	MOUNTING BRACKET, PASSENGER SIDE, INNER		
2	3/8-16 X 1-1/2" HEX HEAD BOLT		
2	3/8" FLAT WASHER		
2	3/8" LOCK WASHER		
2	3/8-16 HEX NUT		
16	1/2-13 X 2" HEX HEAD BOLT		
16	1/2" FLAT WASHER		
16	1/2" LOCK WASHER		
16	1/2-13 HEX NUT		

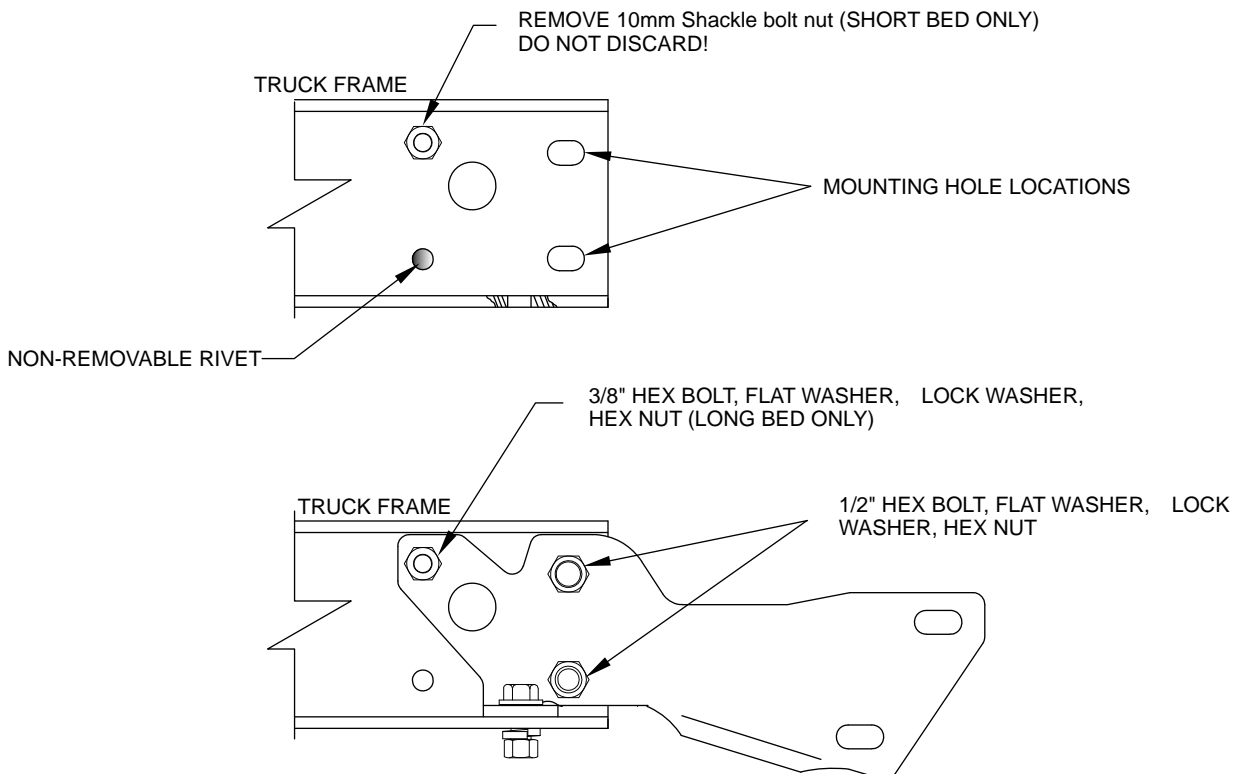

FIGURE 1

STEP 1: (SHORT BED ONLY) Remove the 10mm shackle bolt nuts from both frame rails prior to installing mounting brackets. DO NOT DISCARD! (See Figure 1).

STEP 2: Using 1/2 inch hardware, loosely install inner and outer mounting brackets on the inside and outside of truck frame rails (Refer to Figure 1 and 2). Long bed models install 3/8 inch hardware (as shown below). Short bed models re-install 10mm shackle bolt nut. DO NOT TIGHTEN mounting hardware. **(NOTE: RE-USE FACTORY BRACKETS FOR 31100 & 32100)**

STEP 3: Install bumper onto mounting brackets with inner brackets inside of bumper hitch. See Figure 2. Use remaining 1/2 inch hardware. DO NOT TIGHTEN.

STEP 4: Position bumper squarely to tailgate and allow clearance for tailgate to open. Tighten hardware as follows: 3/8 inch to 30-35 ft lbs, 1/2 inch to 60-65 ft lbs, 10mm to 32-38 ft lbs.

STEP 5: Install rubber grommet into the spare tire crank hole. Using square plastic grommets and sheet metal screws, install license plate (See Figure 3).

STEP 6: Install license plate lights into bumper (See Figure 4). Using supplied connectors, splice plate light wires into truck illumination wire as shown (See Figure 4). Make sure license plate lights are working properly.

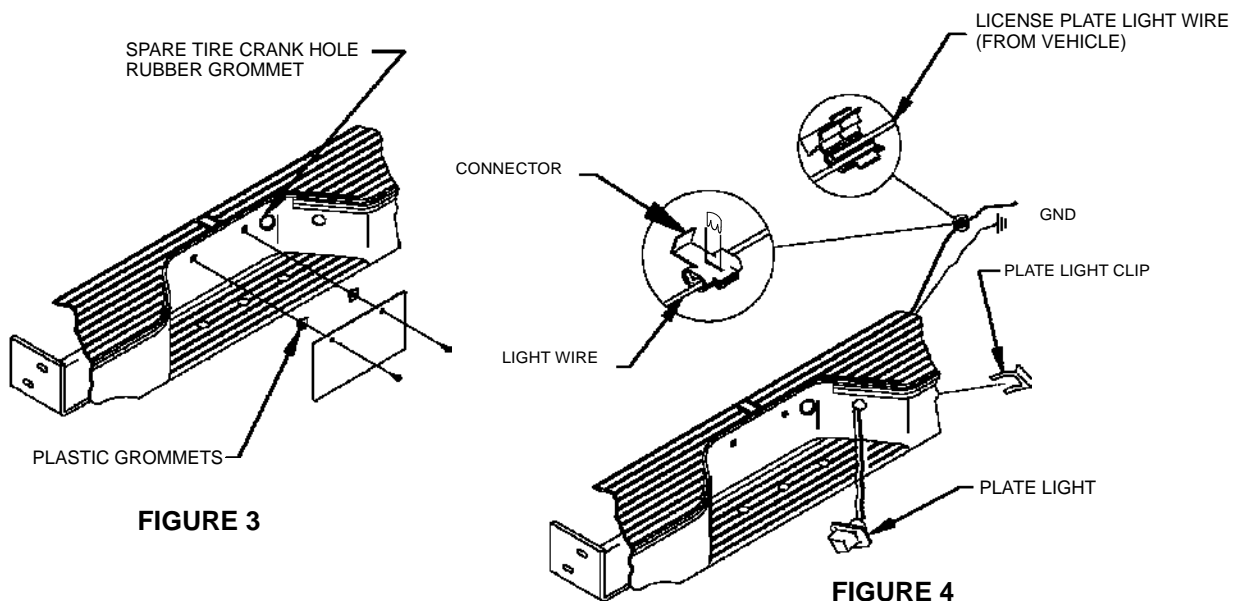
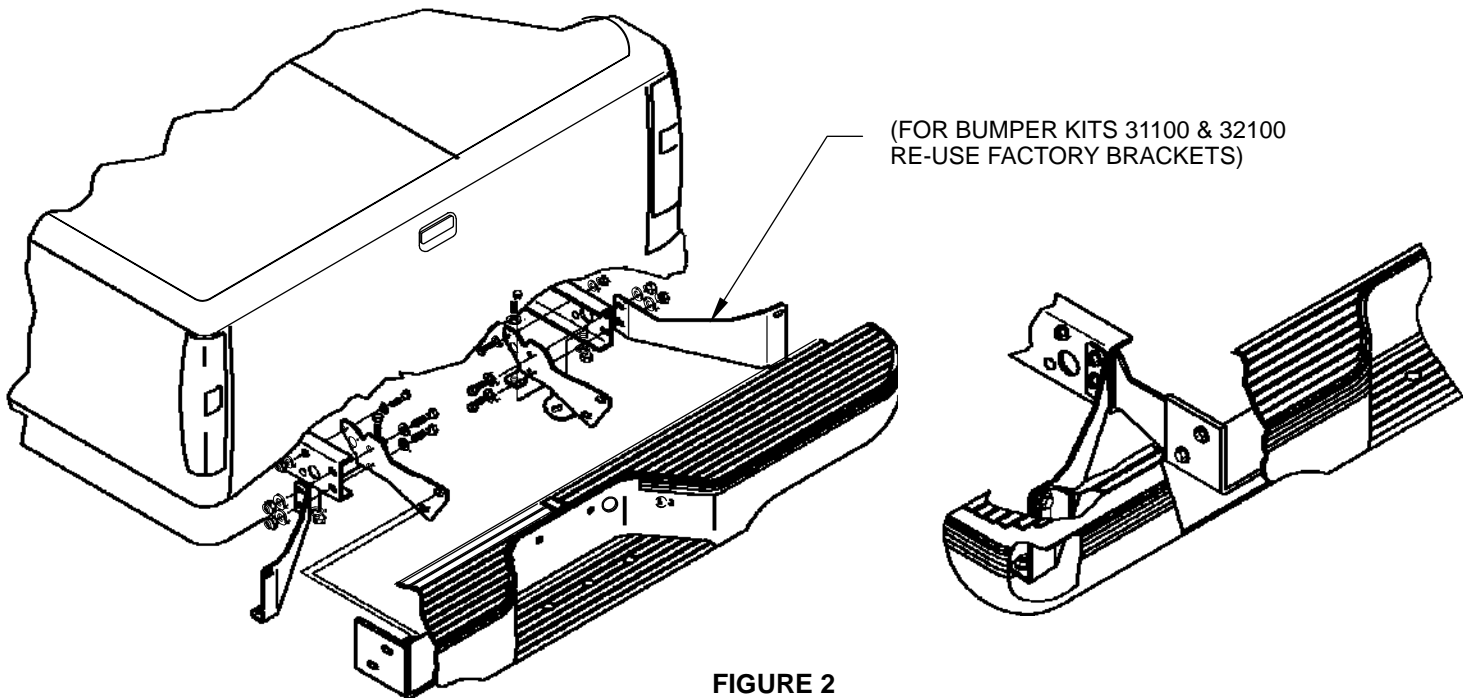

FEY AUTOMOTIVE PRODUCTS