

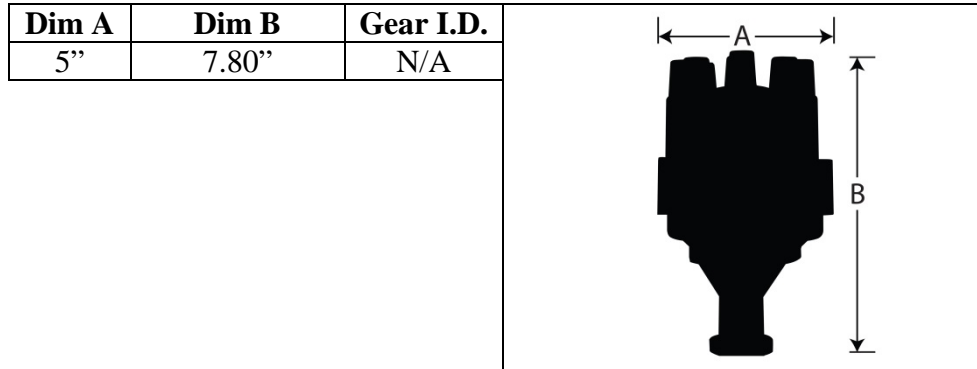

## INSTRUCTIONS

### #305012 & 305013 XFI™ Chrysler Big Block (383-400A Series)/ Hemi/440RB Series Dual Sync Distributor

Thank you for choosing FAST™ products; we are proud to be your manufacturer of choice. Please read this instruction sheet carefully before beginning installation, and also take a moment to review the included limited warranty information.



**Revision Identification:** (CLASSIC) wire colors –RED-BLACK-YELLOW-BROWN  
(NEW) wire colors –RED-BLACK-WHITE-BLACK w/white stripe.

#### **Installation Instructions:**

Two ignition strategies to choose from:

- A. **One** degree reference angle
  - The simplest method to set up your XFI™ distributor
  - Allows you to phase the distributor at TDC (top dead center) so you only need a TDC mark on your balancer
  - You can not activate the individual cylinder control feature when using the one degree reference angle.
- B. **50** degree reference angle
  - Most accurate method for timing control
  - Supports individual cylinder control
  - Requires a 50 degree mark on balancer

**Warning! Before beginning installation, disconnect the negative cable from battery.**

### Wiring Instructions:

- A. The 8 pin connector on the distributor harness will plug directly into the “Cam/Hall Effect” connector on the XFI™ Main Harness.



- B. The red wire coming from the distributor needs to be connected to a 12V ignition source. The wire labeled “12V HE” in the XFI™ Main Harness is a convenient source for this. Remember to connect the opposite end of the “12V HE” wire to a 12V source that is hot with the key in the Run position and during cranking.

### Wire Functions

- Red Wire: 12v +
- (Classic) Yellow Wire: (New) Black w/white stripe Cam Signal
- (Classic) Brown Wire: (New) White Wire Crank Signal
- Black Wire: Signal Ground

### Distributor Cap

The #1 plug wire terminal is marked with a band. Be sure to connect the #1 plug wire to this terminal.

**Cam and Crank LEDs:** There are two LED lights at the base of the module in the distributor. They are powered through the red wire. The cam LED illuminates once per revolution and the crank LED illuminates 8 times per revolution. On the (Classic) model the LED’s are both red. On the (New) model the cam LED is green and the crank LED is red.

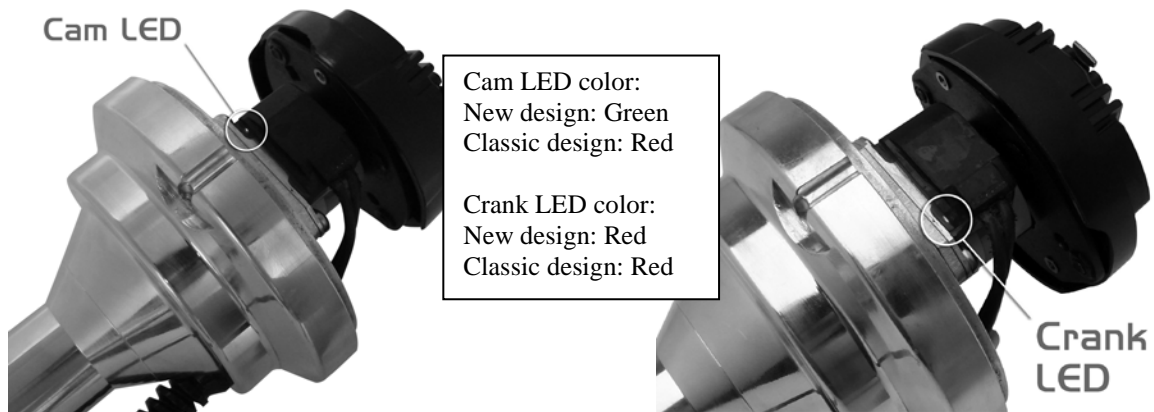

**One degree reference angle installation instructions:**

**Warning! Make sure that the negative coil wire is disconnected from the ignition coil until you are ready to start the engine. Failure to disconnect the negative coil wire could result in electric shock and/or permanent damage to the distributor module not covered by the warranty.**

1. Remove rotor to verify that module is mounted in the one degree position. If not, remove two module mounting screws, and shift the module to the one degree position, replace rotor.
2. Rotate engine to TDC on the compression stroke.
3. Disconnect the negative coil (coil trigger) wire.
4. Reconnect the negative battery cable.
5. Install distributor with the rotor pointing in the general direction of the number one cylinder.
6. With the red wire connected to 12V, the ignition key in the run position, and the “Cam/Hall Effect” plug connected, rotate the base of the distributor clockwise until the cam LED illuminates, then continue clockwise until the next crank signal (crank LED illuminates).
7. Move the base of the distributor back and forth until you find the leading edge of that crank signal, lock down the distributor and you’re finished!

The distributor is now timed and phased properly for a one degree

reference angle! Connect all

spark plug and coil wires before cranking the engine!

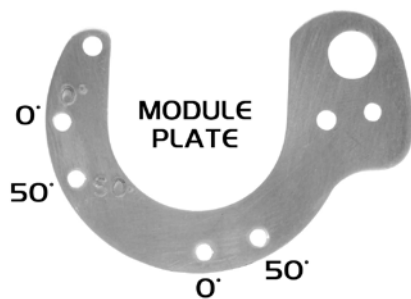

Distributor Assembly  
w/ Module Plate



**One degree ignition strategy setup parameters:**

8. Open C-Com XFI™ software.
9. Establish communications with the XFI™ ECU or select the GCT file you will be using.
10. Click on View, then System Configuration, then Operational Parameters.
11. Click on the button next to “GM Optispark Ignition”.
12. In the box next to “Reference Angle” type “1”
13. You are now ready to run in Sequential mode.

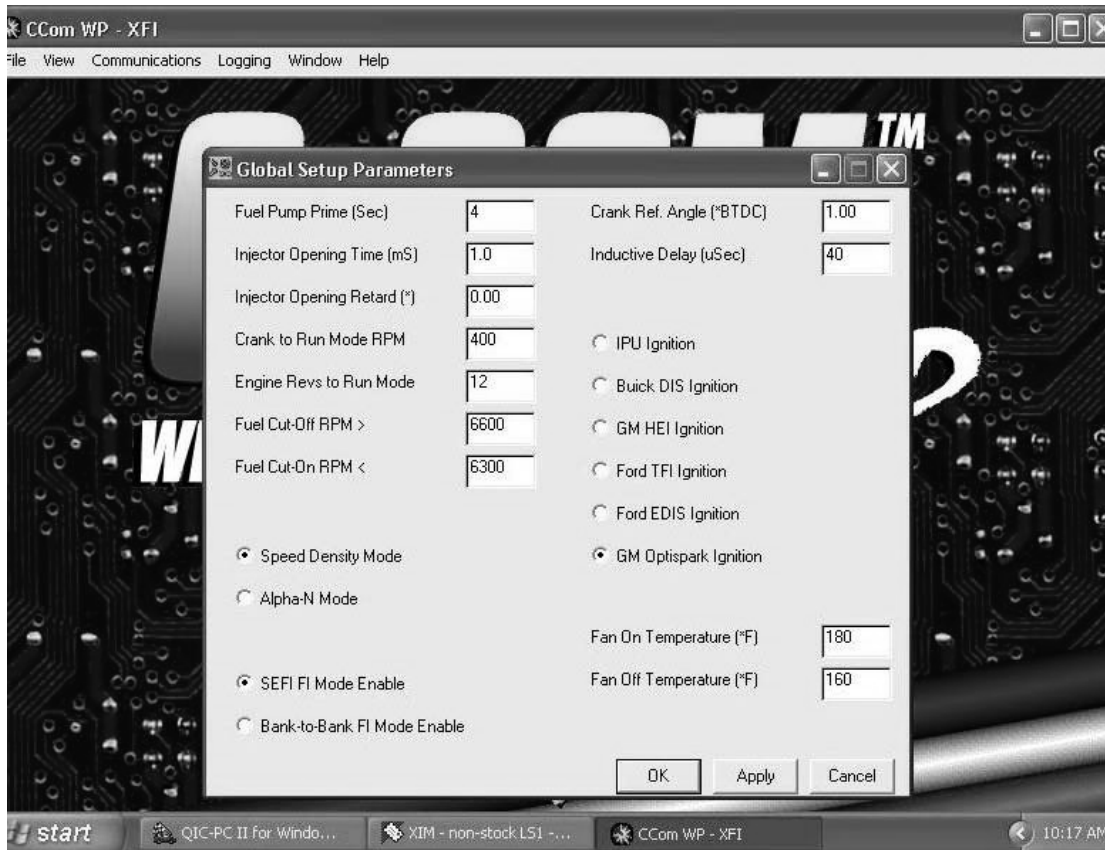

**Note:** As with any distributor installation, use a high-quality timing light to verify ignition timing matches the timing advance commanded by the XFI™. If necessary, make slight adjustments with the distributor to correct this.

**Note:** Be sure to verify that the distributor gear you are using is compatible with your cam gear. You can purchase the revolutionary COMP Cams® composite distributor gears and bronze distributor gears from FAST™

#### Fifty degree reference angle installation instructions:

**Warning!** Make sure that the negative coil wire is disconnected from the ignition coil until you are ready to start the engine. Failure to disconnect the negative coil wire could result in electric shock and/or permanent damage to the distributor module not covered by the warranty.

1. Remove rotor to verify that module is mounted in the 50 degree position, if not, remove two module mounting screws, and shift the module to the 50 degree position, replace rotor.
2. Rotate engine to 50 degrees BTDC on the compression stroke.
3. Disconnect the negative coil (coil trigger) wire.
4. Reconnect the negative battery cable.
5. Install distributor with the rotor pointing in the general direction of the number one cylinder.

6. With the red wire connected to 12V, the ignition key in the run position, and the “Cam/Hall Effect” plug connected, rotate the base of the distributor clockwise until the cam LED illuminates, then continue clockwise until the next crank signal (crank LED illuminates).
7. Move the base of the distributor back and forth until you find the leading edge of that crank signal, lock down the distributor and you’re finished.

The distributor is now timed and phased properly for a fifty degree reference angle! Connect all spark plug and coil wires before cranking the engine!

**Note: Formula for locating crankshaft angle: (Diameter\*Pi)/360\*(number of degrees you’re looking to make the mark at).** For example, if you’re trying to find the 50 degree mark for a 6.820” in diameter balancer:

$$(6.820 * 3.1416) = 21.425712$$

$$21.425712 / 360 = .0595158$$

$$.0595158 * 50 = 2.97579$$

That means the 50 degree mark is 2.976" BTDC.



**Fifty degree ignition strategy setup parameters:**

8. Open C-Com XFI™ software.
9. Establish communications with the XFI™ ECU, or select the GCT file you will be using.
10. Click on View, then System Configuration, then Operational Parameters.
11. Click on the button next to “IPU Ignition”
12. In the box next to “Reference Angle” type “50”.
13. You are now ready to run in Sequential mode and take advantage of the individual cylinder control feature of the XFI™.

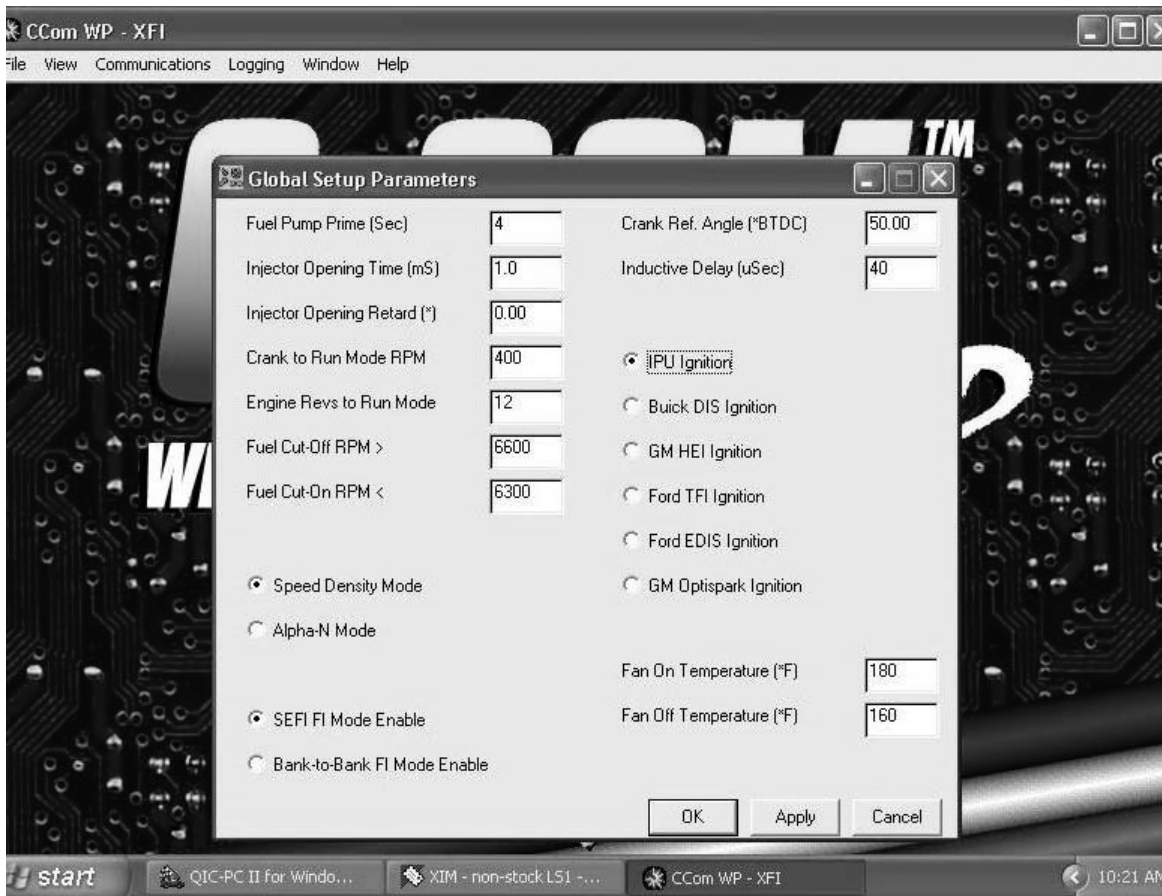

**Note:** As with any distributor installation, use a high-quality timing light to verify ignition timing matches the timing advance commanded by the XFI™. If necessary, make slight adjustments with the distributor to correct this.

**Note:** Be sure to verify that the distributor gear you are using is compatible with your cam gear. You can purchase the revolutionary COMP Cams® composite distributor gears and bronze distributor gears from FAST™.