



INSTALLATION INSTRUCTIONS

DIRT LOGIC 2.5 COILOVERS

FTS26061

2005-13 TOYOTA TACOMA 2WD/4WD

2006-12 TOYOTA FJ 4WD



- PARTS LIST -

- TOOL LIST -

FTS26061 DIRT LOGIC 2.5 COILOVERS		
Qty	Part #	Description
2	FT825252	Dirt Logic 2.5 Coliover
2	FT833121	Raised Upper Mount
2	FT86038	Hardware
2	50132251785	1/2"-13 x 2 1/4"
1	FT260311i	Instructions

Required Tools (Not Included)

- Floor Jack
- Jack Stands
- Assorted Metric and S.A.E sockets, and Allen wrenches
- Torque Wrench
- Barrel Sander
- Spanner Wrench (FTS98008)

- PRE-INSTALLATION NOTES -

Read this before you begin installation -

Check all parts to the parts list above before beginning installation.

Read all instructions thoroughly from start to finish before beginning the installation. If these instructions are not properly followed severe frame, driveline and / or suspension damage may occur.

Check your local city and state laws prior to the installation of this system for legality. Do not install if not legal in your area.

Prior to the installation of this suspension system perform a front end alignment and record. Do not install this system if the vehicle alignment is not within factory specifications. Check for frame and suspension damage prior to installation.

WARNING- Installation of this system will alter the center of gravity of the vehicle and may increase roll over as compared to stock.

Dirt Logic Shocks are built to exacting standards and are properly tuned for you vehicle in order to optimize your ride. Remember that each Dirt Logic Shock is designed and built to both beautify and upgrade your vehicle so special care should be taken when installing and cleaning your new Dirt Logic Shocks.

This Dirt Logic Shock is shipped pressurized with nitrogen. Pay careful attention not to discharge this shock without proper tools and training. Do not use any heavy degreaser or other acidic cleaner on any part of this shock.

Be aware that the coil has some amount of preload from the factory and should not be removed without proper tools and training.

Do not alter the finish of these components (ex: chroming, zinc plating, or painting). Changing the finish can cause structural fatigue of components.

FOOTNOTE -

The FT825251 Coilover was designed for use with the FTS26028/FTS26034/FTS26044/FTS26045/FTS26046 Uniball Upper Control Arm system and will not fit the factory upper control arm.

- INSTRUCTIONS -

FRONT SUSPENSION

1. Disconnect the negative terminal on the battery. Jack up the front end of the truck and support the frame rails with jack stands. **NEVER WORK UNDER AN UNSUPPORTED VEHICLE!** Remove the front tires.
2. Starting on the driver side of the vehicle, remove the front shock from the truck by removing the tie rod end and upper arm from the spindle. Use a floor jack to support the lower arm when removing the upper arm. Remove the three nuts from the top of the shock and the bolt from the bottom. Remove the shock from the truck. **SEE FIGURE 1**

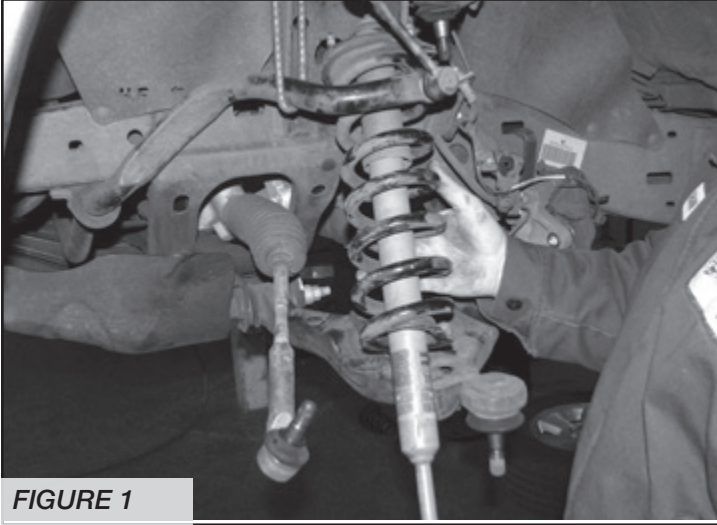

FIGURE 1

3. Using 1-1/2" Barrel sander, sand a small notch in the lip at the top of the bucket. The radius should be on both sides of the bucket parallel to the front of the bucket. This radius is to add clearance the shock pivot bolt. **SEE FIGURES 2-3**

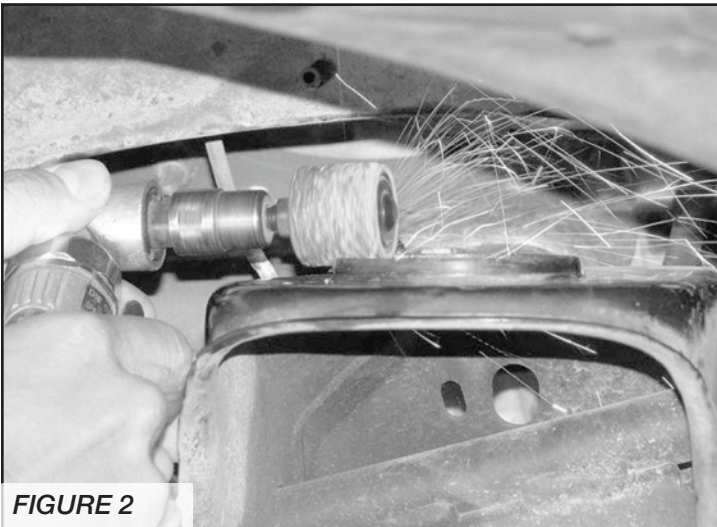

FIGURE 2

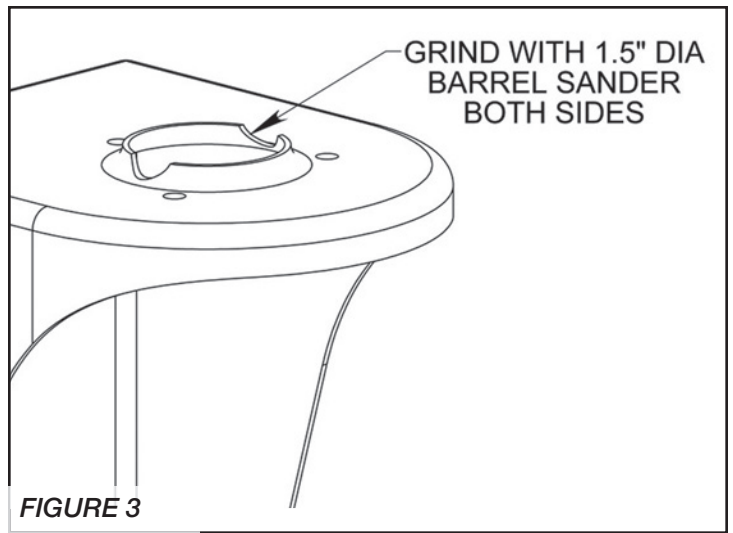

FIGURE 3

4. Locate FT825252 Dirt Logic 2.5 Coilover, FT833121 upper mount and supplied 3/8" hardware. Install Coilover FT833121 upper mount using the supplied 3/8" hardware and torque 37 ft-lbs. **SEE FIGURES 4-5**

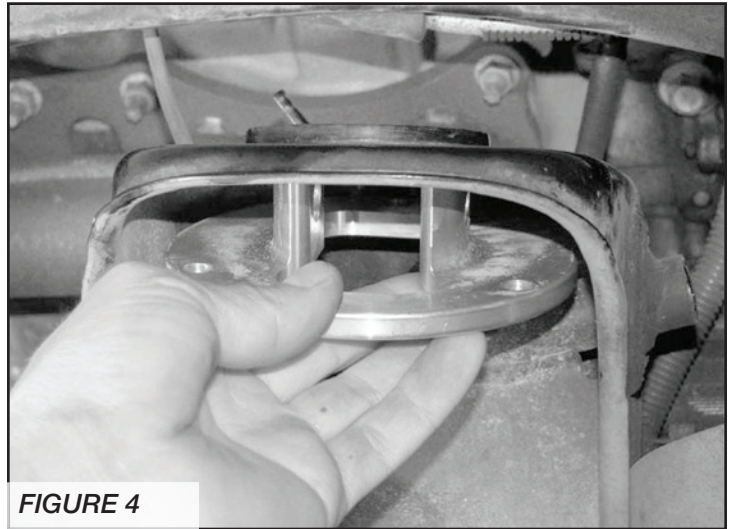

FIGURE 4

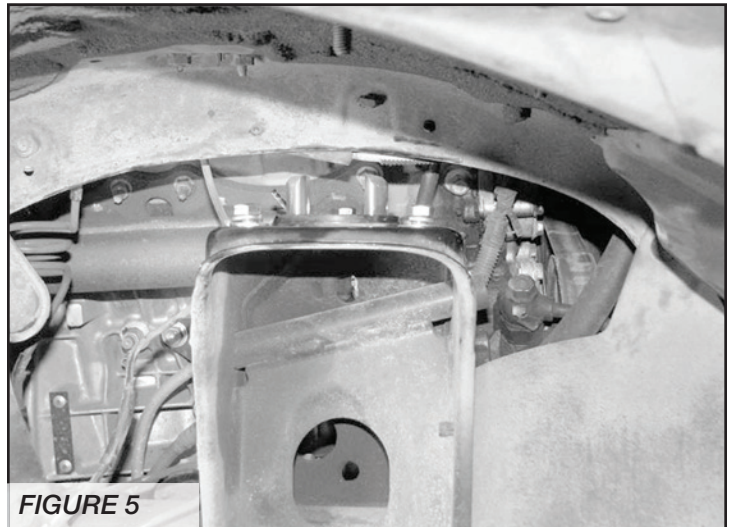

FIGURE 5

5. Install the FT825251 Coilover into the new upper mount using the ½-13 x 2-¼ bolt from the shock hardware. Torque 90 Ft-lbs **SEE FIGURES 6-8**

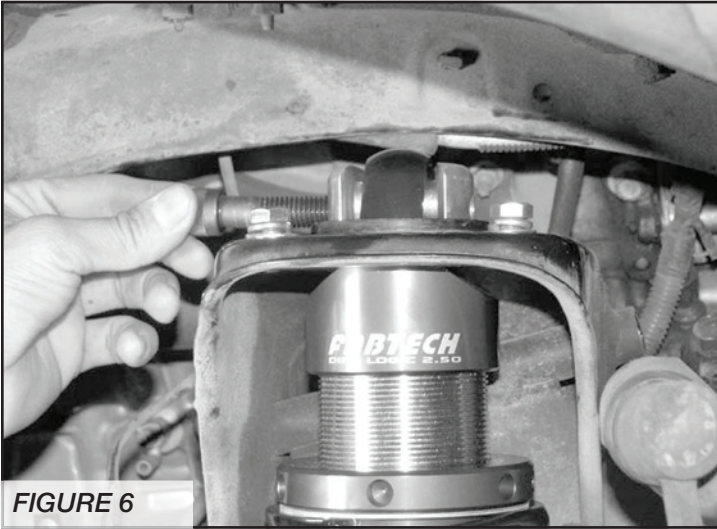

FIGURE 6

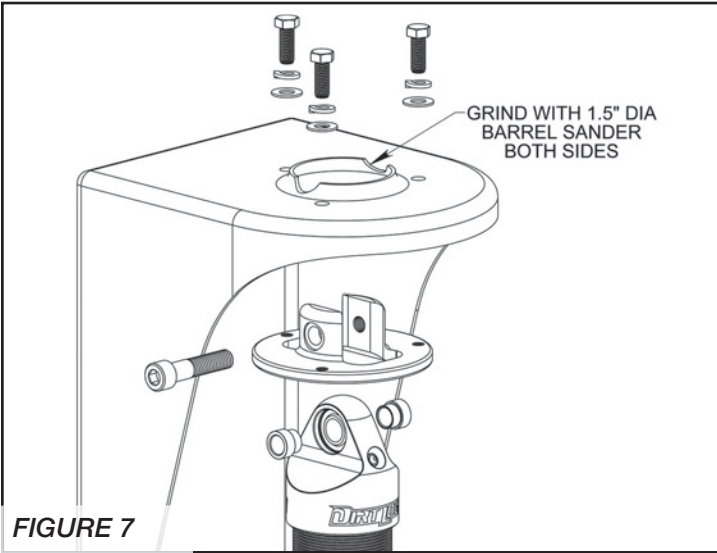

FIGURE 7

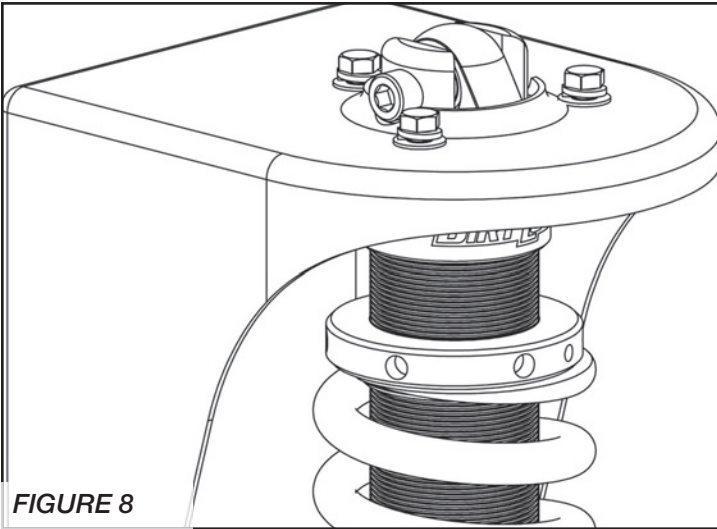

FIGURE 8

6. Install the rod end at the bottom of the shock into the lower control arm with the larger misalignment to the front of the Vehicle. Reinstall the factory bolt into the lower mount. Torque 100 Ft-lbs. **SEE FIGURE 9**

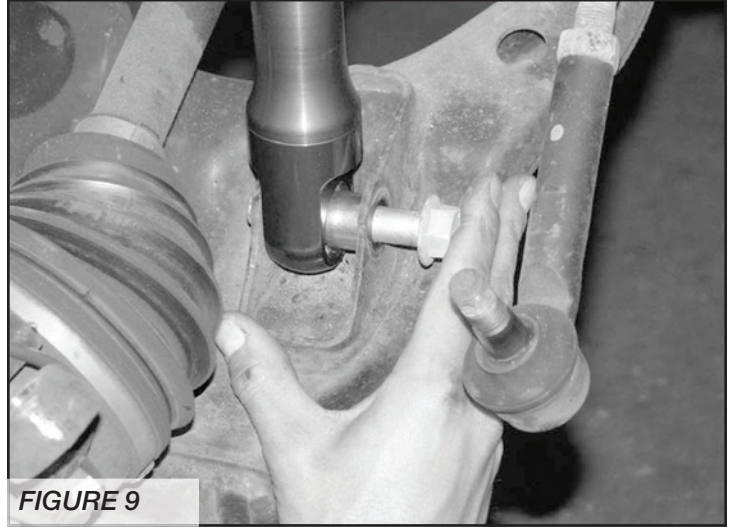

FIGURE 9

7. Recheck all bolts for proper torque.
8. Install tires and wheels and torque lug nuts to wheel manufacturer's specifications. Turn front tires left to right and check for appropriate tire clearance. **Note - Some oversized tires may require trimming of the front bumper & valance.**
9. Check front end alignment and set to factory specifications. Readjust headlights.
10. Recheck brake hoses, ABS wires and suspension parts for proper tire clearance while turning tires fully left to right.
11. Install Driver Warning Decal. Complete product registration card and mail to Fabtech in order to receive future safety and technical bulletins on this suspension

Vehicles that will receive oversized tires should check ball joints and all steering components every 2500-5000 miles for wear and replace as required.

RETORQUE ALL NUTS, BOLTS AND LUGS AFTER 50 MILES AND PERIODICALLY THEREAFTER.

- Product Warranty and Warnings -

Fabtech provides a Limited Lifetime Warranty to the original retail purchaser who owns the vehicle, on which the product was originally installed, for defects in workmanship and materials.

The Limited Lifetime Warranty excludes the following Fabtech items; bushings, bump stops, ball joints, tie rod ends, limiting straps, cross shafts, heim joints and driveshafts. These parts are subject to wear and are not considered defective when worn. They are warranted for 60 days from the date of purchase for defects in workmanship.

Dirt Logic and Performance Coilover take apart shocks are considered a serviceable shock with a one year warranty on leakage only. Service seal kits are available separately for future maintenance. All other shocks are covered under our Limited Lifetime Warranty.

Fabtech does not warrant any product for finish, alterations, modifications and/or installation contrary to Fabtech's instructions. Alterations to the finish of the parts including but not limited to painting, powder coating, plating and/or welding will void all warranties. Some finish damage may occur to parts during shipping, which is considered normal and is not covered under warranty.

Fabtech products are not designed nor intended to be installed on vehicles used in race applications or for racing purposes or for similar activities. (A "RACE" is defined as any contest between two or more vehicles, or any contest of one or more vehicle against the clock, whether or not such contest is for a prize). This warranty does not include coverage for police or taxi vehicles, race vehicles, or vehicles used for government or commercial purposes. Also excluded from this warranty are sales outside of the United States of America.

Installation of most suspension products will raise the center of gravity of the vehicle and will cause the vehicle to handle differently than stock. It may increase the vehicle's susceptibility to a rollover, on road and off road, at all speeds. Extreme care should be taken to operate the vehicle safely at all times to prevent rollover or loss of control resulting in serious injury or death. Fabtech front end Desert Guards may impair the deployment or operation of vehicles equipped with supplemental restraining systems/air bag systems and should not be installed if the vehicle is equipped as so.

Fabtech makes every effort to ensure suspension product compatibility with all vehicles listed on the website, but due to unknown auto manufacturer's production changes and/or inconsistencies by the auto manufacturer, Fabtech cannot be responsible for 100% compatibility, including the fitment of tire and wheel sizes listed. The Tire and Wheel sizes listed in Fabtech's website are only a guideline for street driving with noted fender trimming. Fabtech is not responsible for damages to the vehicle's body or tires. Fabtech is not responsible for premature wear of factory components due to the installation of oversized tires and wheels.

Fabtech's obligation under this warranty is limited to the repair or replacement, at Fabtech option, of the defective product only. All costs of removal, installation or re-installation, freight charges, incidental or consequential damages are expressly excluded from this warranty. Fabtech is not responsible for damages and/or warranty of other vehicle parts related or non related to the installed Fabtech product. This warranty is expressly in lieu of all other warranties expressed or implied. This warranty shall not apply to any product that has been subject to accident, negligence, alteration, abuse or misuse as determined by Fabtech.

Fabtech suspension components must be installed as a complete system including shocks as shown on our website. All warranties will become void if Fabtech parts are combined and/or substituted with other aftermarket suspension products. Combination and/or substitution of other aftermarket suspension parts may cause premature wear and/or product failure resulting in an accident causing injury or death. Fabtech does not warrant products not manufactured by Fabtech.

Depending on the condition of the factory suspension components retained after the installation of a Fabtech suspension not all vehicles may have the same ride stance front to rear as described in the website. The blue color of suspension components shown in all Fabtech photographs are for display purposes only. Majority of all Fabtech components will be black specifically where noted with part numbers ending in BK.

Installation of Fabtech product may void the vehicles factory warranty; it is the consumer's responsibility to check with their local vehicle's dealer for warranty disposition before the installation of the product. Some state laws may prohibit modification of suspension to a vehicle in whole or in part. It is the responsibility of the installer and consumer to consult local laws prior to the installation of any Fabtech suspension product to comply with such written laws.

Instruction Sheet Part# - FT26061i

SE 03/02/15