



INSTALLATION INSTRUCTIONS

FTS24129		1.75-5" CHROMOLY FRONT TRACK BAR
1	FT50483BK	CHROMOLY FRONT TRACK BAR
1	FT50504	HARDWARE SUBASSEMBLY

FT50504		HARDWARE SUBASSEMBLY
1	FTS98003	3/4" ROD END
2	FT95066	MISALIGNMENT
1	75160003252	JAM NUT 3/4-16 RH
1	FTLOCK	THREAD LOCKING COMPOUND
1	FTAS12	STICKER FT BLUE 10X4
1	FTAS16	DRIVER WARNING DECAL
1	FTREGCARD	REGISTRATION CARD
1	FT24129I	INSTRUCTIONS

2007-17 JEEP WRANGLER 1.75-5" CHROMOLY FRONT TRACK BAR

FT24129i



- TOOL LIST -

Required Tools (Not Included)

Basic Hand Tools
Floor Jack
Jack Stands
Assorted Metric and S.A.E sockets, and Allen wrenches
Torque Wrench

NOTE: REFER TO OPTIONAL KIT BOX INSTRUCTIONS PRIOR TO INSTALLATION.

- PRE-INSTALLATION NOTES -

READ THIS BEFORE YOU BEGIN INSTALLATION -

Check all parts to the parts list above before beginning installation.

Read all instructions thoroughly from start to finish before beginning the installation. If these instructions are not properly followed severe frame, driveline and / or suspension damage may occur.

Check your local city and state laws prior to the installation of this system for legality. Do not install if not legal in your area.

Prior to the installation of this suspension system perform a front end alignment and record. Do not install this system if the vehicle alignment is not within factory specifications. Check for frame and suspension damage prior to installation.

The installation of this suspension system should be performed by two professional mechanics.

This suspension must be installed with Fabtech shock absorbers.

Use the provided thread locking compound on all hardware.

WARNING- Installation of this system will alter the center of gravity of the vehicle and may increase roll over as compared to stock.

Vehicles that receive oversized tires should check ball joints, uniballs, tie rods ends, pitman arm and idler arm every 2500-5000 miles for wear and replace as needed.

Verify differential fluid is at manufactures recommended level prior to kit installation. Installation of the kit will reposition the differential and the fill plug hole may be in a different position. (For example, if the manufacture recommends 3 quarts of fluid, make sure the diff has 3 quarts of fluid). Check your specific manual for correct amount of fluid.

- INSTRUCTIONS -

1. Disconnect the negative terminal on the battery. Jack up the front end of the truck and support the frame rails with jack stands. **NEVER WORK UNDER AN UNSUPPORTED VEHICLE!**
2. Remove the factory hardware that connects the track bar to the frame and axle. Discard the factory track bar and save hardware.
3. Install the 3/4" jam nut onto the rod end until its stops. Then, install the rod end into the new Fabtech track bar. **NOTE: When the rod end is adjusted all the way in equals stock length. This is a good starting point when installing. Adjustments may be required depending on the amount of lift you have or if using in conjunction with a track bar bracket.**
4. Install the new Fabtech track bar using the supplied misalignments and factory hardware. The rod end side should be installed to the axle. Also, the bend needs to be installed away from the axle. Leave loose. **SEE FIGURES 1-2**

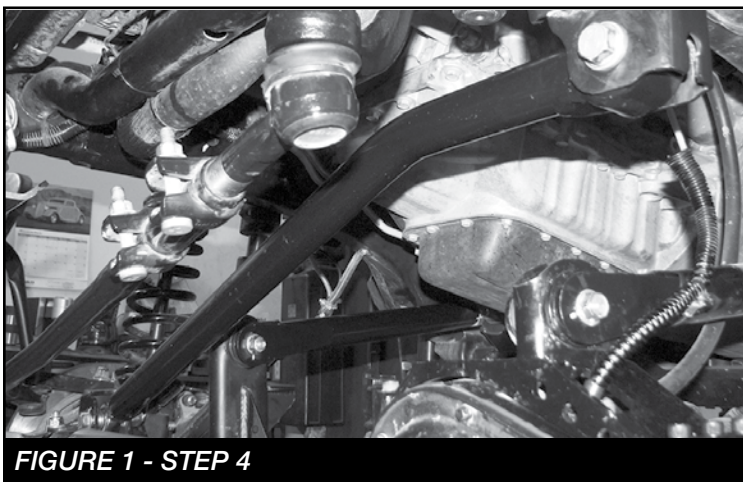

FIGURE 1 - STEP 4

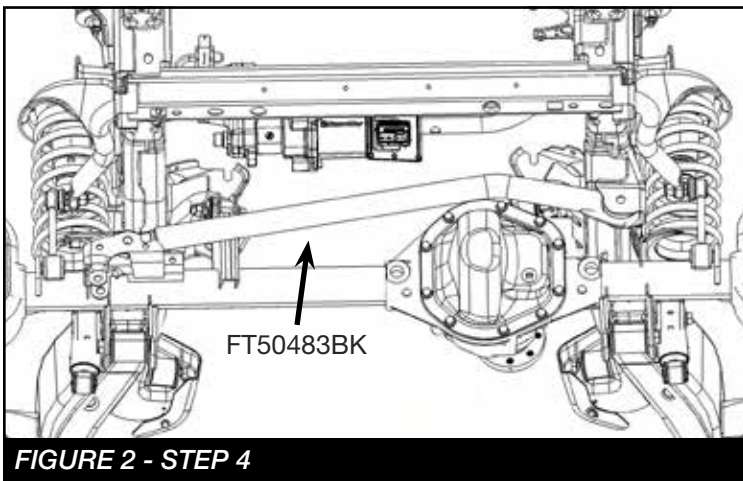

FIGURE 2 - STEP 4

5. Once the vehicle is on the ground proceed with tightening the hardware. Torque to 180 ft-lbs.
6. Check front end alignment and set to factory specifications. Readjust headlights.
7. Install Driver Warning Decal. Complete product registration card and mail to Fabtech in order to receive future safety and technical bulletins on this suspension.

Vehicles that will receive oversized tires should check ball joints, uniballs and all steering components every 2500-5000 miles for wear and replace as required.

RE-TORQUE ALL NUTS, BOLTS AND LUGS AFTER 50 MILES AND PERIODICALLY THEREAFTER.