



INSTALLATION INSTRUCTIONS



2014 DODGE 3500 4WD

5" SYSTEMS

FTS23047/FTS23159 - BASIC SYSTEMS

FTS23058/FTS23163 - RADIUS ARM SYSTEMS

- PARTS LIST - BASIC SYSTEMS

FTS23047		5" BASIC SYSTEM W/PERFORMANCE SHOCKS
1	FT44243BK	BUMP STOP MOUNT (DRIVER)
1	FT44244BK	BUMP STOP MOUNT (PASSENGER)
1	FT44236BK	TRACK BAR BRACKET
1	FT44237BK	5" COIL SPACER (DRIVER)
1	FT44238BK	5" COIL SPACER (PASSENGER)
1	FT44172	PITMAN ARM
2	FT44232BK	RADIUS ARM DROP
2	FT44242BK	BUMPSTOP SPACER
2	FTBK21	BLOCK 2.0" W/ 3/4" PIN
4	FT738U	UBOLT RD 9/16-18X12.50X4.00
1	FT44257	HARDWARE KIT
1	FT44261	HARDWARE SUBASSEMBLY
2	FTS7343	PERFORMANCE SHOCK
2	FTS7335	PERFORMANCE SHOCK

FTS23159		5" BASIC SYSTEM W/DIRT LOGIC SHOCKS
1	FT44243BK	BUMP STOP MOUNT (DRIVER)
1	FT44244BK	BUMP STOP MOUNT (PASSENGER)
1	FT44236BK	TRACK BAR BRACKET
1	FT44237BK	5" COIL SPACER (DRIVER)
1	FT44238BK	5" COIL SPACER (PASSENGER)
1	FT44172	PITMAN ARM
2	FT44232BK	RADIUS ARM DROP
2	FT44242BK	BUMPSTOP SPACER
2	FTBK21	BLOCK 2.0" W/ 3/4" PIN
4	FT738U	UBOLT RD 9/16-18X12.50X4.00
1	FT44257	HARDWARE KIT
1	FT44261	HARDWARE SUBASSEMBLY
2	FTS811032	DIRT LOGIC 2.25 NON RESI
2	FTS810362	DIRT LOGIC 2.25 NON RESI

FT44257 - HARDWARE KIT		LOCATION
1	M18-1.5 X 90MM HEX BOLT	TRACK BAR DROP BRACKET
2	M18 WASHERS	
1	M18-1.5 C-LOCK NUT	
2	M18-1.5 X 125MM HEX BOLT	RADIUS ARM POCKET
4	M18 WASHERS	
2	M18-1.5 C-LOCK NUT	
12	1/2-13 X 1-1/4 HEX BOLT G8 ZNC	RADIUS ARM POCKET/ BUMP STOP
24	1/2 SAE WASHER G8 ZINC	
12	1/2-13 C-LOCK NUT ZINC	
2	1/2-13 X 1-1/2 HEX BOLT G8 ZNC	TRACK BAR DROP BRACKET
4	1/2 SAE WASHER G8 ZINC	
2	1/2-13 C-LOCK NUT ZINC	
2	5/16-18 X 2-1/2 HEX BOLT G8 ZINC	BUMP STOP
4	5/16 SAE WASHER G8 ZINC	
2	5/16-18 C-LOCK NUT ZINC	
4	7/16-14 X 1-1/4 HEX BOLT G8 ZC	COIL SPACER/ REAR BUMP STOP
8	7/16 SAE WASHER G8 ZINC	
4	7/16-14 C-LOCK NUT ZINC	
2	1/2-13 X 3-1/2 BUTTONHEAD BOLT	COIL SPACER
4	1/2 SAE WASHER G8 ZINC	
2	1/2-13 C-LOCK NUT ZINC	
4	1/4-20 X 1 HEX BOLT G5 ZINC	BRAKE LINE EXTENSION
2	1/4 SAE WASHER G5 ZINC	
2	1/4-20 C-LOCK NUT ZINC	

FT44261		HARDWARE SUBASSEMBLY
2	FT604	SLEEVE 1.000 X .760 X 2.600
1	FT120	SLEEVE 1.000 X .563 X 310
2	FT44135	BUMP STOP MOUNT TAB
1	FT44239	WASHER 4.250 X .510 X .250
2	FT44245	BRAKE LINE EXT
1	FT44246	TRACK BAR SUPPORT SPACER
2	FT44253	RADIUS ARM DROP NUT TAB
2	FT44258	1/4 NUT TAB
2	FTS88	BUMPSTOP 1 IN TALL LOW RND
1	FT916H	9/16" UBOLT HARDWARE KIT
1	FTAS16	DRIVER WARNING DECAL
1	FTREGCARD	REGISTRATION CARD
1	FT23047I	INSTRUCTIONS

- PARTS LIST - RADIUS ARM SYSTEMS

FTS23058		5" RADIUS ARM W/PERFORMANCE SHOCKS
1	FT44243BK	BUMP STOP MOUNT (DRIVER)
1	FT44244BK	BUMP STOP MOUNT (PASSENGER)
1	FT44236BK	TRACK BAR BRACKET
1	FT44230BK	RADIUS ARM (DRIVER)
1	FT44231BK	RADIUS ARM (PASSENGER)
1	FT44237BK	5" COIL SPACER (DRIVER)
1	FT44238BK	5" COIL SPACER (PASSENGER)
1	FT44172	PITMAN ARM
2	FT44242BK	BUMPSTOP SPACER REAR
2	FTBK21	BLOCK 2.0" W/ 3/4" PIN
4	FT738U	UBOLT RD 9/16-18X12.50X4.00
1	FT44275	HARDWARE KIT
1	FT44281	HARDWARE SUBASSEMBLY
2	FTS7343	PERFORMANCE SHOCK
2	FTS7335	PERFORMANCE SHOCK
2	FT90071	LOGO PLATE

FTS23163		5" RADIUS ARM W/DIRT LOGIC SHOCKS
1	FT44243BK	BUMP STOP MOUNT (DRIVER)
1	FT44244BK	BUMP STOP MOUNT (PASSENGER)
1	FT44236BK	TRACK BAR BRACKET
1	FT44230BK	RADIUS ARM (DRIVER)
1	FT44231BK	RADIUS ARM (PASSENGER)
1	FT44237BK	5" COIL SPACER (DRIVER)
1	FT44238BK	5" COIL SPACER (PASSENGER)
1	FT44172	PITMAN ARM
2	FT44242BK	BUMPSTOP SPACER REAR
2	FTBK21	BLOCK 2.0" W/ 3/4" PIN
4	FT738U	UBOLT RD 9/16-18X12.50X4.00
1	FT44275	HARDWARE KIT
1	FT44281	HARDWARE SUBASSEMBLY
2	FTS811032	DIRT LOGIC 2.25 NON RESI
2	FTS810362	DIRT LOGIC 2.25 NON RESI
2	FT90071	LOGO PLATE

FT44275 - HARDWARE KIT		LOCATION
1	M18-2.5 X 90MM HEX BOLT	TRACK BAR DROP BRACKET
2	M18 WASHERS	
1	NUT C-LOCK 18MM G10.9	
4	1/2-13 X 1-1/4 HEX BOLT G8	BUMP STOP
8	1/2 SAE WASHER G8	
4	1/2-13 C-LOCK NUT	
2	1/2-13 X 1-1/2 HEX BOLT G8	
4	1/2 SAE WASHER G8	
2	1/2-13 C-LOCK NUT	
2	5/16-18 X 2-1/2 HEX BOLT G8	
4	5/16 SAE WASHER G8	
2	5/16-18 C-LOCK NUT	
4	7/16-14 X 1-1/4 HEX BOLT G8	
8	7/16 SAE WASHER G8	
4	7/16-14 C-LOCK NUT	
2	1/2-13 X 3-1/2 BUTTONHEAD BOLT	
4	1/2 SAE WASHER G8	
2	1/2-13 C-LOCK NUT	
4	1/4-20 X 1 HEX BOLT G5	
2	1/4 SAE WASHER G5	
2	1/4-20 C-LOCK NUT	
2	THREAD LOCKING COMPOUND 2 MIL	

FT44281		HARDWARE SUBASSEMBLY
2	FT102	SLEEVE 1.000 X .732 X 3.280
1	FT44239	WASHER 4.250 X .510 X .250
2	FT44245	BRAKE LINE EXT
1	FT44246	TRACK BAR SUPPORT SPACER
2	FT1006	BUSHING
2	FT44258	1/4 NUT TAB
2	FTS88	BUMPSTOP 1 IN TALL LOW RND
1	FT916H	9/16" UBOLT HARDWARE KIT
1	FTAS16	DRIVER WARNING DECAL
1	FTREGCARD	REGISTRATION CARD
1	FT23047I	INSTRUCTIONS
2	FT44135	BUMP STOP MOUNT TAB



- TOOL LIST -

Required Tools (Not Included)

Basic Hand Tools
Floor Jack
Jack Stands
Assorted Metric and S.A.E sockets, and Allen wrenches
Torque Wrench
Die Grinder w/ Cutoff Wheel or Sawzall

- PRE-INSTALLATION NOTES -

Read this before you begin installation-

Check all parts to the parts list above before beginning installation. If any parts are missing contact Fabtech at 909-597-7800 and a replacement part will be sent to you immediately.

Read all instructions thoroughly from start to finish before beginning the installation. If these instructions are not properly followed severe frame, driveline and / or suspension damage may occur.

Check your local city and state laws prior to the installation of this system for legality. Do not install if not legal in your area.

Prior to the installation of this suspension system perform a front end alignment and record. Do not install this system if the vehicle alignment is not within factory specifications. Check for frame and suspension damage prior to installation.

The installation of this suspension system should be performed by two professional mechanics.

This suspension must be installed with Fabtech shock absorbers.

Use the provided thread locking compound on all hardware.

WARNING- Installation of this system will alter the center of gravity of the vehicle and may increase roll over as compared to stock.

Vehicles that receive oversized tires should check ball joints, uniballs, tie rods ends, pitman arm and idler arm every 2500-5000 miles for wear and replace as needed.

Verify differential fluid is at manufactures recommended level prior to kit installation. Installation of the kit will reposition the differential and the fill plug hole may be in a different position. (For example, if the manufacture recommends 3 quarts of fluid, make sure the diff has 3 quarts of fluid). Check your specific manual for correct amount of fluid.

RECOMMENDED TIRE/WHEEL SIZES -

Use 37x12.50/R17 tire w/ 17x9 wheels w/ 5" BS w/ minor trimming

Use 37x12.50/R18 tire w/ 18x9 wheels w/ 5" BS w/ minor trimming

Use 37x13.50/R20 tire w/ 20x9.5 wheels w/ 5" BS w/ minor trimming

- INSTRUCTIONS -

FRONT SUSPENSION

1. Disconnect the negative terminal on the battery. Jack up the front end of the truck and support the frame rails with jack stands. **NEVER WORK UNDER AN UNSUPPORTED VEHICLE!** Remove the front tires.
2. **DRIVER SIDE ONLY** - Starting on the driver side, remove the driver side fender liner.
3. Remove the factory shock and discard. Retain factory lower hardware.
4. Disconnect factory sway bar links.
5. Remove factory coil spring and rubber isolator. Retain these parts for later use.
6. Remove the factory pitman arm and discard. Keep hardware.
7. Locate the new FT44172 Fabtech pitman arm and install. Do not reconnect the factory drag link at this time. Reinstall the factory lock washer plus thread locker. Torque to 220ft-lbs.
8. Unthread the factory drag link at the adjuster sleeve and remove adjuster sleeve. **SEE FIGURE 1**

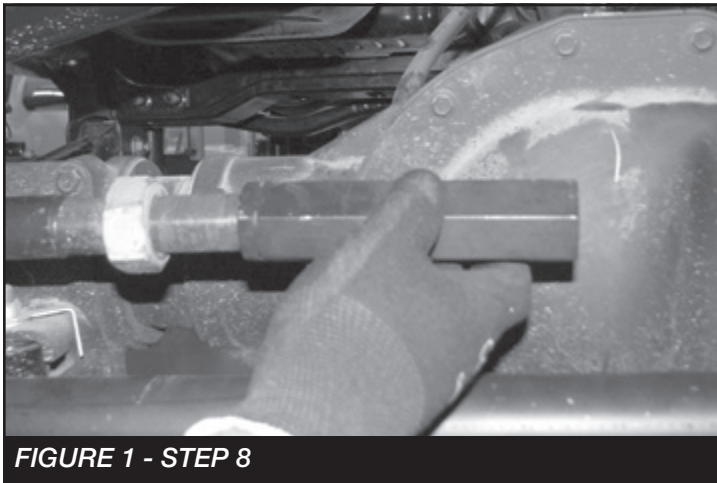

FIGURE 1 - STEP 8

9. Using a die grinder remove the flat nonthreaded section from both ends of the drag link. This will allow you to rotate the drag link and line it up with the pitman arm. **SEE FIGURES 2-4**

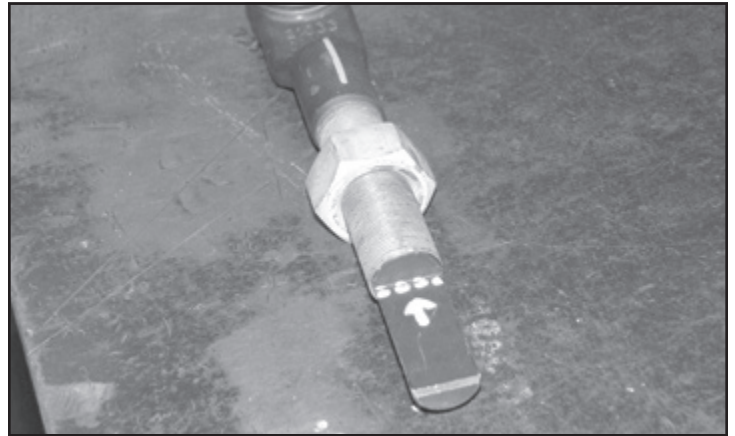

FIGURE 2 - STEP 9

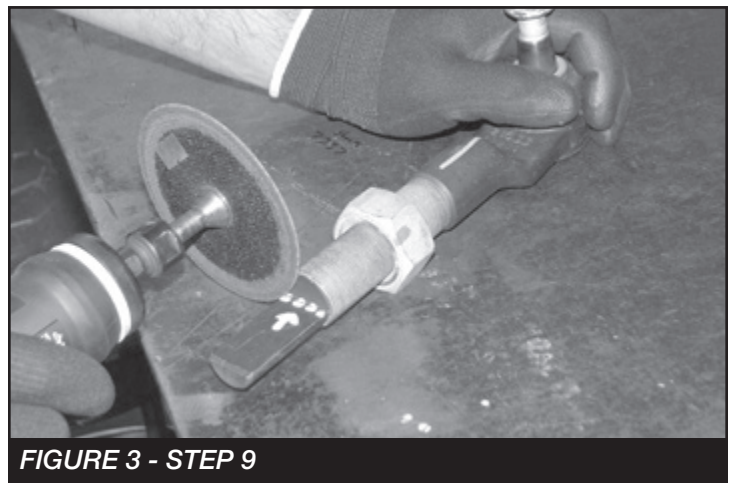

FIGURE 3 - STEP 9

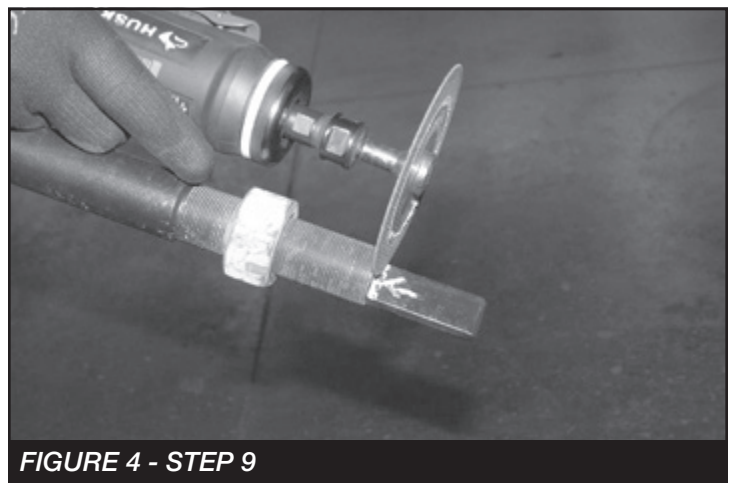
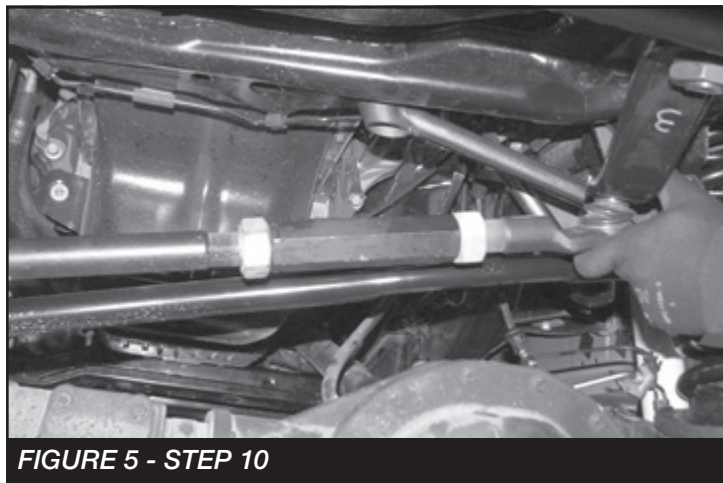
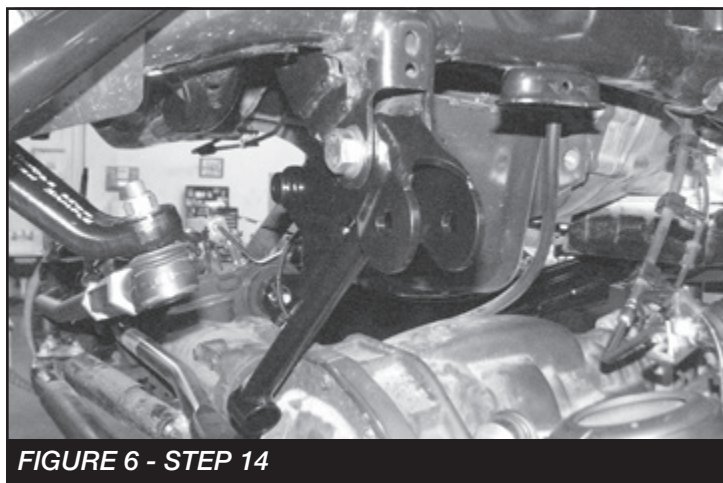

FIGURE 4 - STEP 9

10. Reassemble the drag link and connect it to the new pitman arm. **SEE FIGURE 5**



11. Torque the drag link to 83 ft-lbs.
12. Remove the track bar from the frame side of the vehicle.
13. Locate the FT44236BK track bar bracket and M18-1.5 x 120mm bolt.
14. Slide the track bar bracket into the factory mount and insert the M18 bolt into the factory pivot hole. **SEE FIGURE 6**



15. Rotate the bracket up until the end of the bracket is flush with the crossmember under the motor.
16. Using the Fabtech bracket as a guide, mark the factory mount for the upper driver side mounting hole.

17. Swing the bracket back out of the way. Using a 1/2" drill bit, drill out the marked hole. **SEE FIGURE 7**

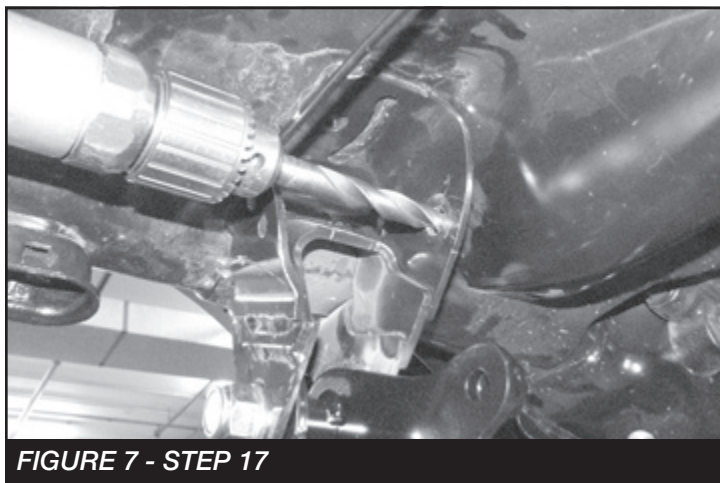

18. Locate one FT44246 sleeve and two 1/2"-13 x 1-1/2" bolts, nuts and washers.
19. Rotate the track bar bracket back into place and bolt together using 1/2"-13 x 1-1/2" bolts and the sleeve. **SEE FIGURES 8-9**

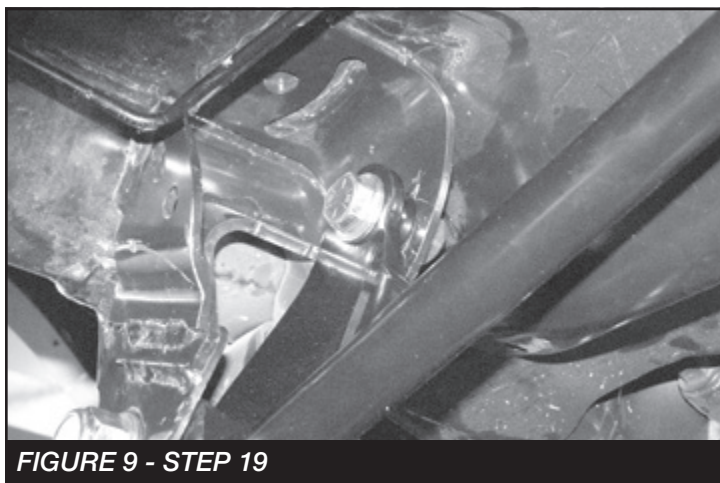
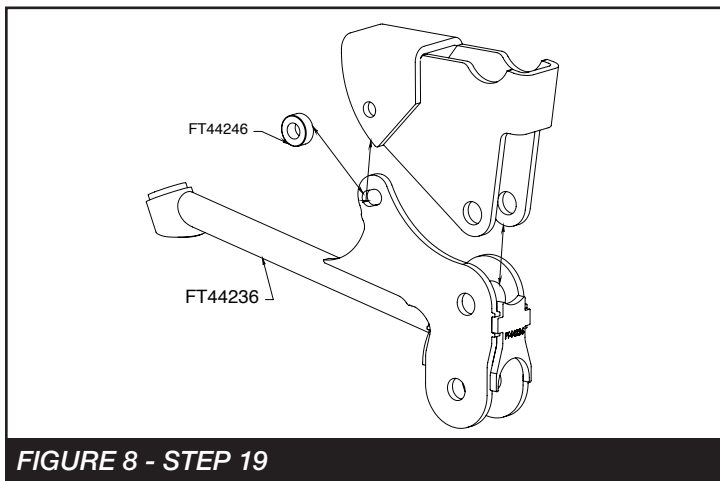

20. Using the Fabtech bracket as a guide, drill a 1/2" hole in the cross member under the motor. **SEE FIGURE 10**



FIGURE 10 - STEP 20

21. **DRIVER SIDE ONLY** - Locate the Brake control module on the top of the coil bucket. **SEE FIGURE 11**

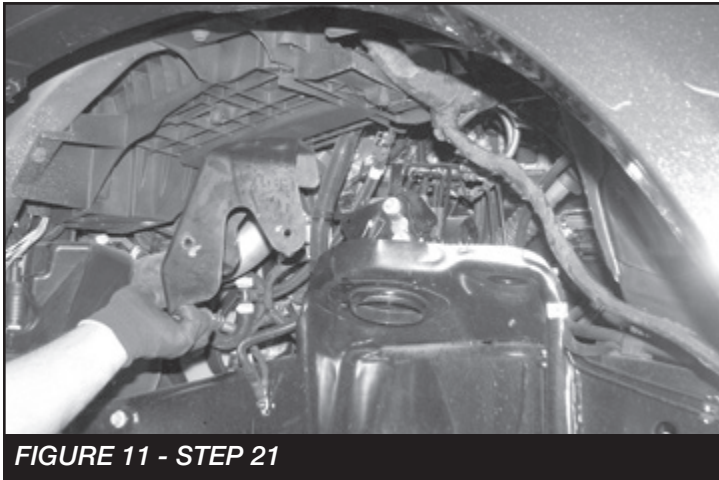

FIGURE 11 - STEP 21

22. Remove the bolts that attach the module to the mounting bracket on the top of the bucket. Retain hardware. **SEE FIGURE 12**

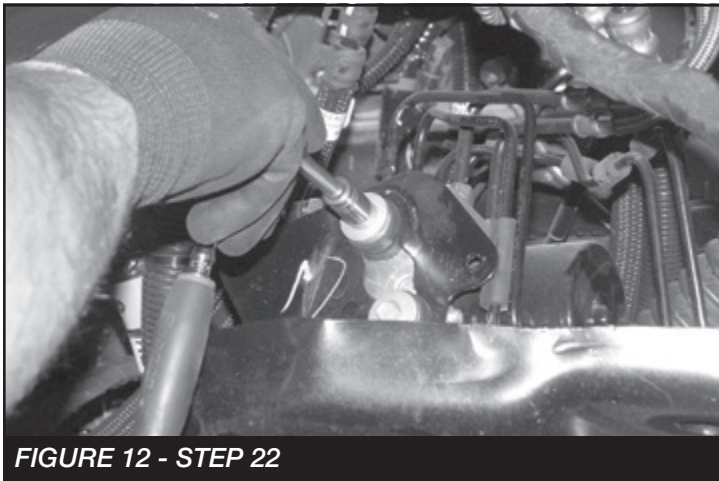

FIGURE 12 - STEP 22

23. Lift the module with care not to damage any brake lines and install the 1/2" -13 x 4" button head bolt and washer through the top hole in the coil bucket. **SEE FIGURES 13-14**

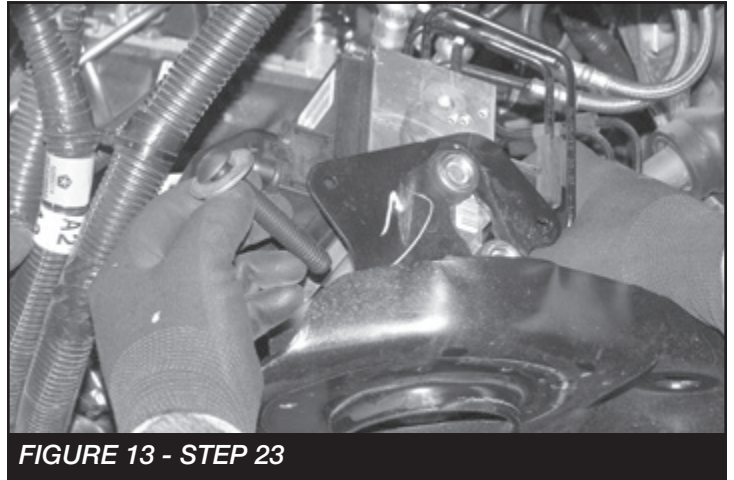

FIGURE 13 - STEP 23

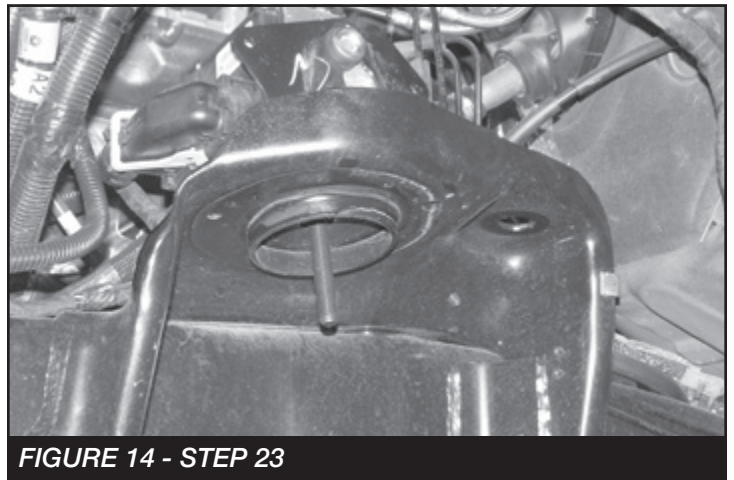

FIGURE 14 - STEP 23

24. Locate the FT4437BK coil spacer. Install the coil spacer into the top of the factory coil bucket passing the button head bolt through the center hole in the Fabtech coil spacer. Attach a flat washer and locking nut to the 1/2" button head bolt. Leave loose at this time. **SEE FIGURE 15**

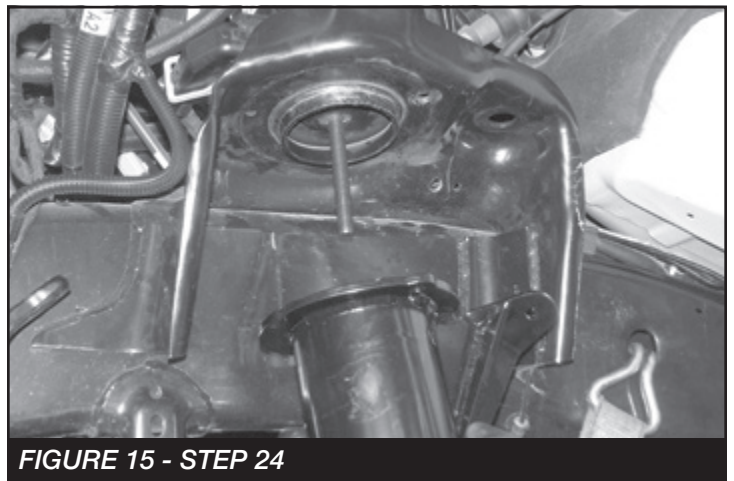

FIGURE 15 - STEP 24

25. Install a 7/16"-14 x 1-1/4" bolt, nut and washer through the coil bucket in the locating tab on the Fabtech spacer. **SEE FIGURE 16**



FIGURE 16 - STEP 25

26. Torque the 7/16" bolt to 59 ft-lbs and the 1/2" button head bolt to 90 ft-lbs. **SEE FIGURE 17**

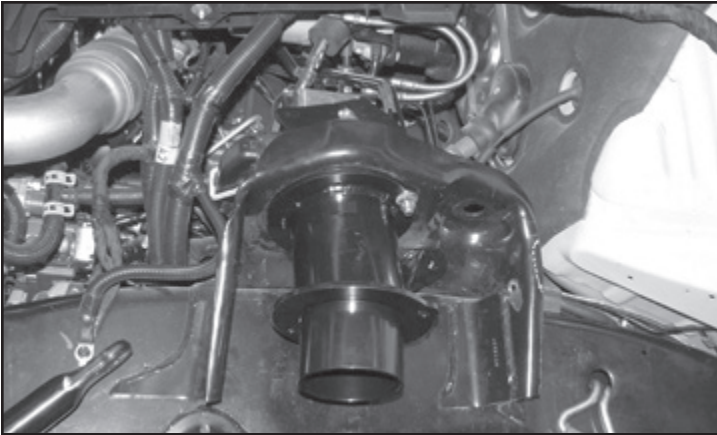

FIGURE 17 - STEP 26

27. Using the support tab on the coil spacer as a drill guide, drill a 7/16" hole through the factory coil bucket. **SEE FIGURE 18**

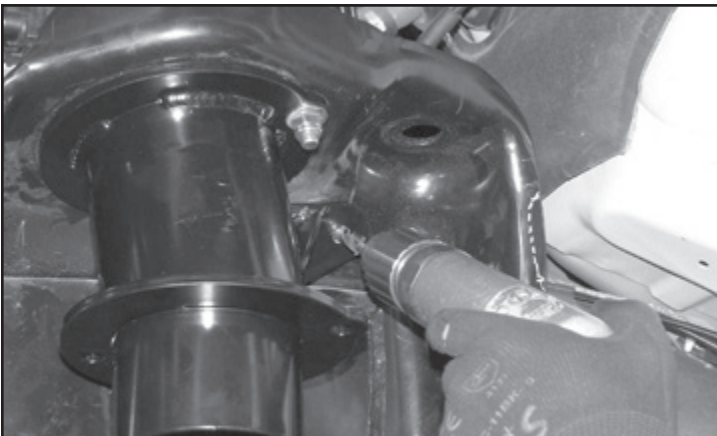

FIGURE 18 - STEP 27

28. Install a 7/16"-14 x 1-1/4" bolt, nut and washer through the coil bucket and torque the 7/16" bolt to 59 ft-lbs. **SEE FIGURE 19**



FIGURE 19 - STEP 28

29. Locate and remove the factory rubber bump stop. **SEE FIGURE 20**

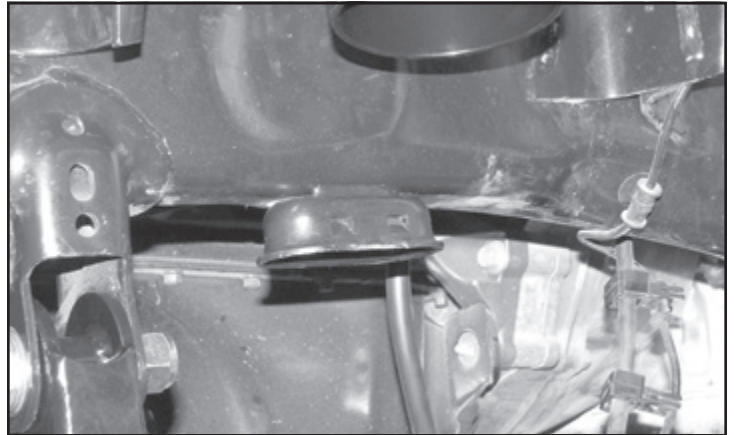

FIGURE 20 - STEP 29

30. Using a die grinder, grind out the stamped in tabs on the inside of the bump stop housing. **SEE FIGURES 21-22**

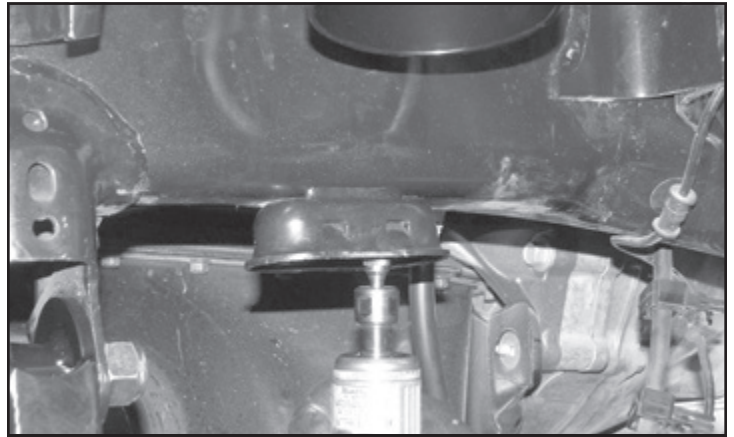

FIGURE 21 - STEP 30

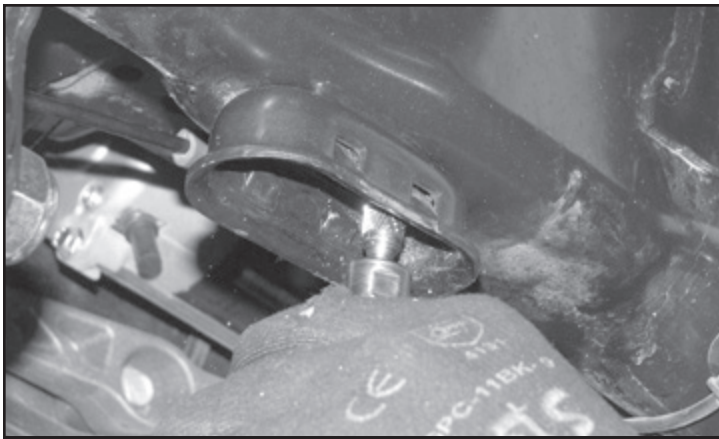

FIGURE 22 - STEP 30

31. Locate the FT44243BK driver front bump stop and the FT44135 nut tab.
32. Using a 1/2" drill bit, drill out the hole in the factory crossmember inline with the factory bump stop mount. **SEE FIGURE 23**

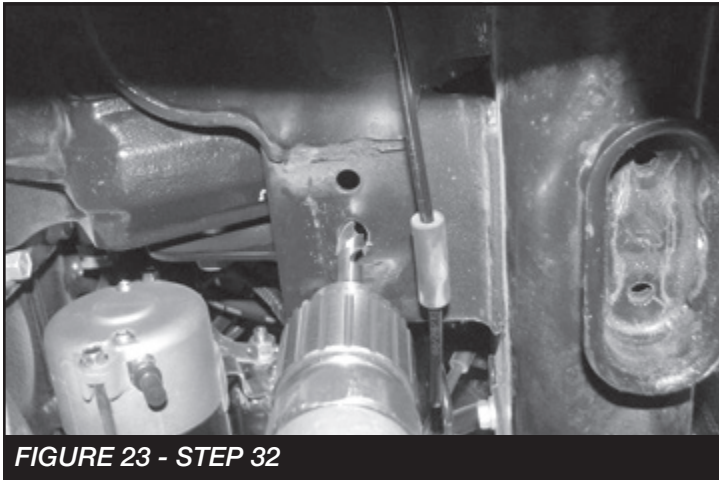

FIGURE 23 - STEP 32

33. Slide the bump stop into the factory bump stop mount. Using a 1/2"-13 x 1-1/4" bolt and the nut tab, bolt the bump stop to the crossmember. Torque the 1/2" bolt to 90 ft-lbs. **SEE FIGURES 24-26**

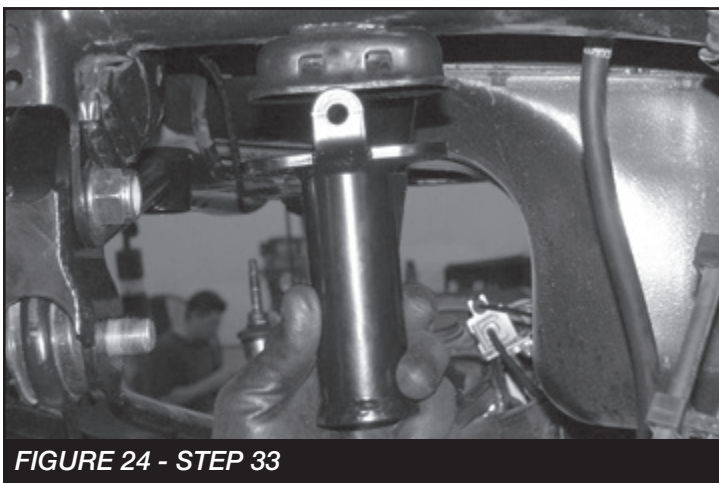

FIGURE 24 - STEP 33

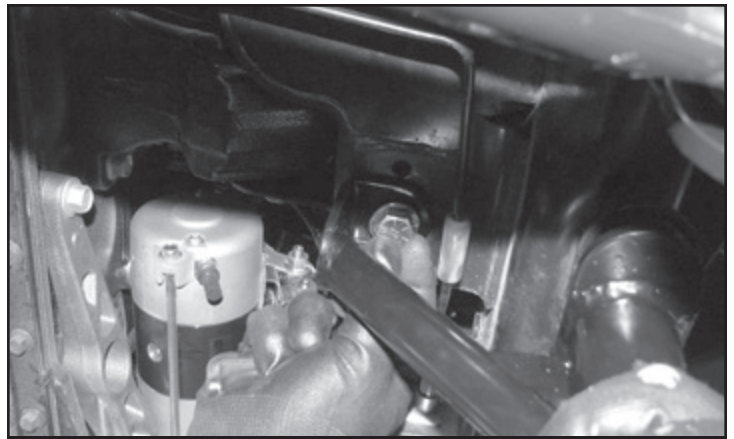

FIGURE 25 - STEP 33

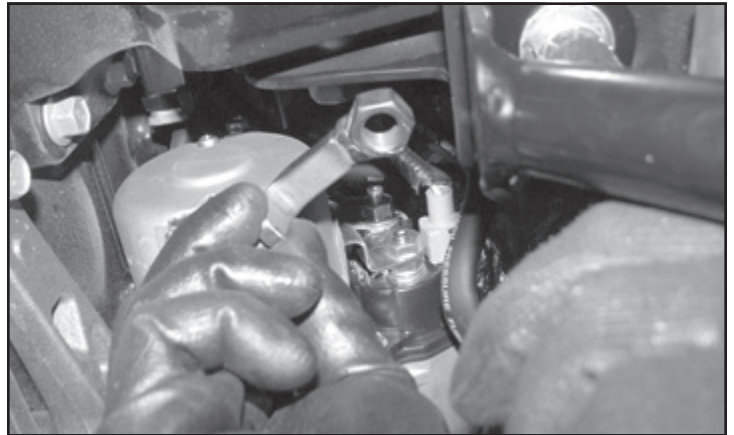

FIGURE 26 - STEP 33

34. Using the outer tab on the bump stop as a drill guide, drill a 5/16" hole all the way through the factory bump stop mount. **SEE FIGURE 26**

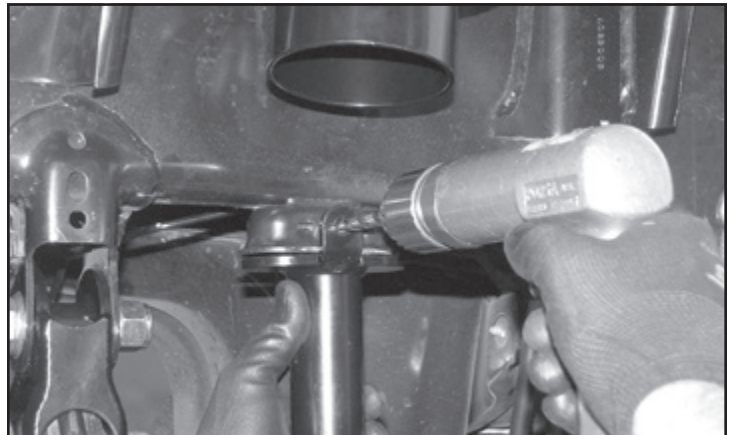

FIGURE 27 - STEP 35

35. Locate a 5/16"-18 x 2-1/2" bolt, nut and washers. Using this bolt, secure the bump stop to the factory bump stop mount and torque to 29 ft-lbs. **SEE FIGURE 28**

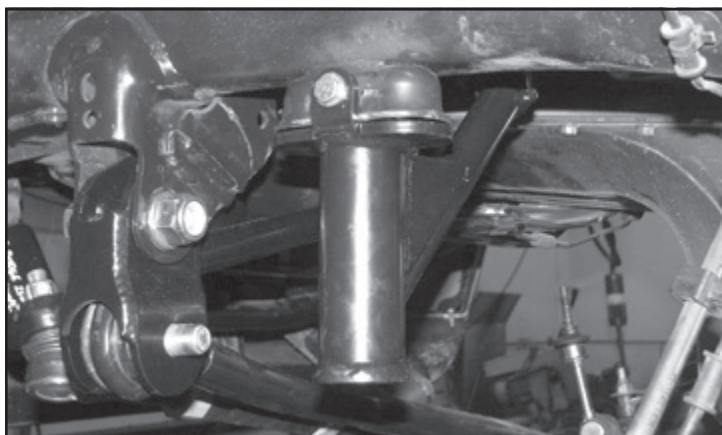

FIGURE 28 - STEP 35

36. Locate the FTS88 bump stop pad and thread it into the bottom of the Fabtech bump stop. **SEE FIGURE 29**

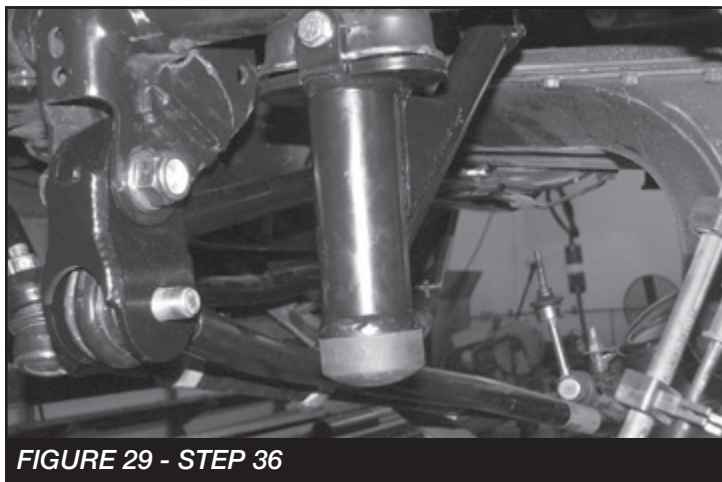

FIGURE 29 - STEP 36

37. Repeat steps 2-36 on the passenger side. On **PASSENGER SIDE ONLY** install the 1/2" -13 x 4" Button head bolt and FT44239 washer though the top hole in the coil bucket.

38. Secure the front diff. Remove the factory driver and passenger side Radius arm. Retain Hardware. **SEE FIGURES 30-31**



FIGURE 30 - STEP 38

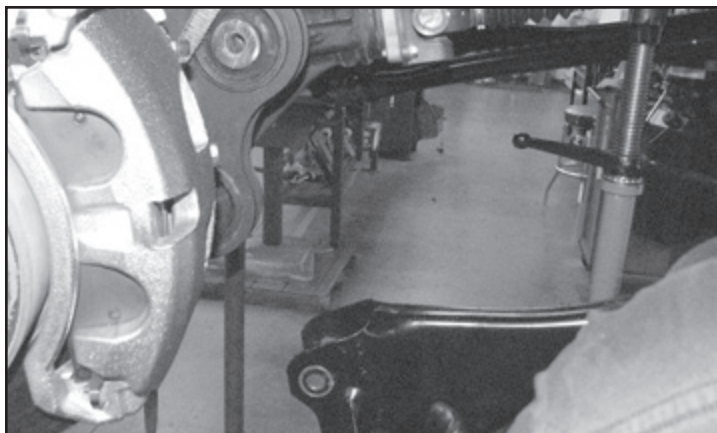

FIGURE 31 - STEP 38

IF INSTALLING FABTECH RADIUS ARMS SKIP TO STEP 51

39. Remove the factory crossmember and skid plate that is mounted between the factory radius arm pockets. Retain Hardware. **SEE FIGURE 32**

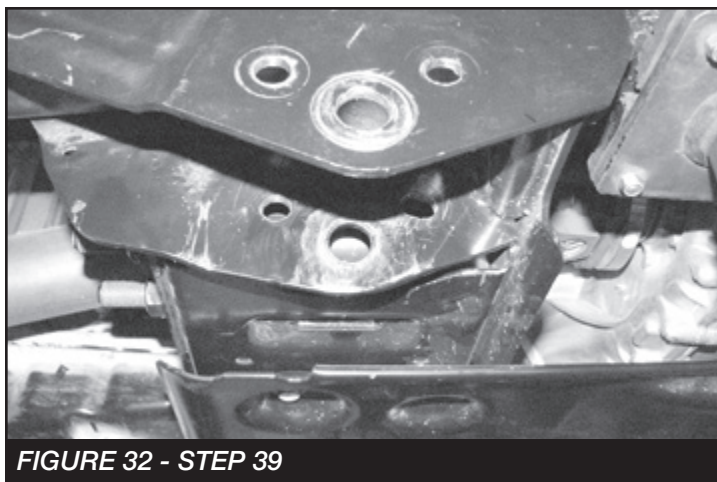

FIGURE 32 - STEP 39

40. Trim 1/2" off both driver and passenger ends of the crossmember leaving a 1/4" border perpendicular to the bolt holes. This will be done to add clearance for the Fabtech radius arm brackets. **SEE FIGURES 33-34**

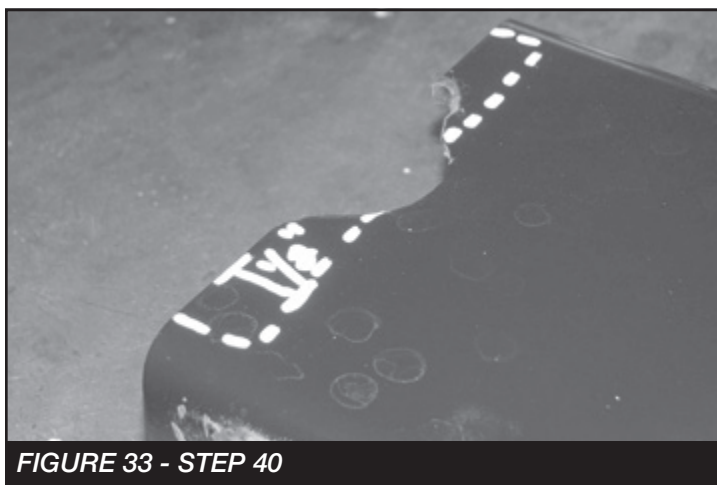

FIGURE 33 - STEP 40

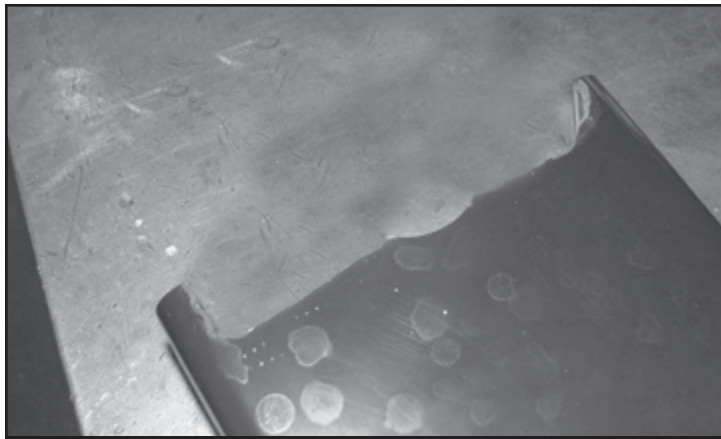

FIGURE 34 - STEP 40

41. Reinstall the factory crossmember and torque to 200 ft-lbs.
42. Locate the Fabtech FT44232BK Radius arm drop bracket and the drill template in the instructions (**Page 17**). Cut out the template.
43. Line up the drill template with the factory Radius arm bracket and mark the two holes around the radius arm pivot bolt. **SEE FIGURE 35**

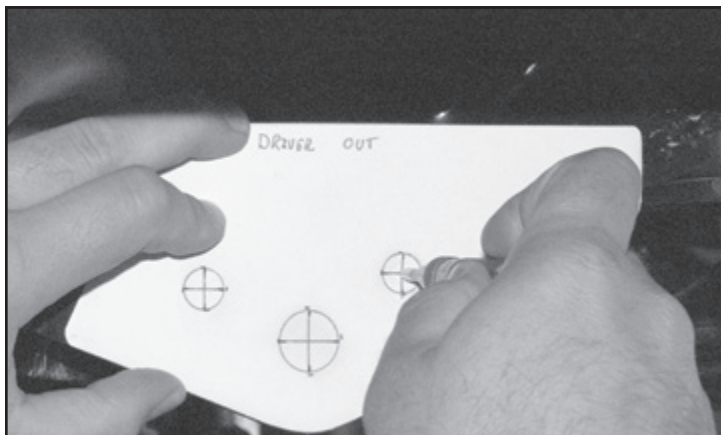

FIGURE 35 - STEP 43

44. Using a 1/2" drill bit, drill all the way through both sides of the factory radius arm mount. **SEE FIGURES 36-37**



FIGURE 36 - STEP 44

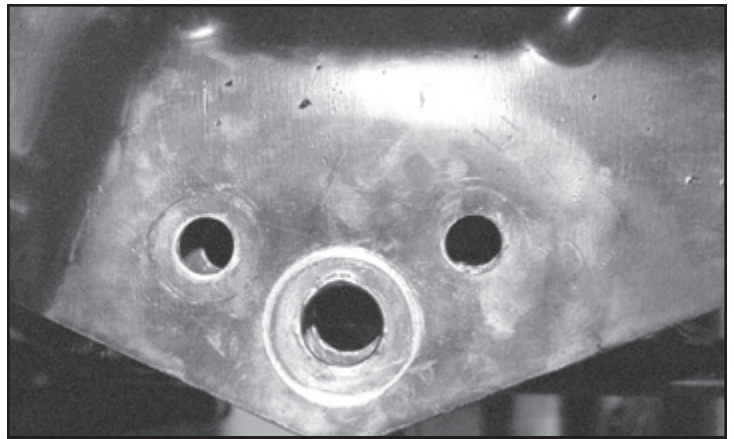

FIGURE 37 - STEP 44

Repeat steps 42 - 44 on the passenger side.

45. Slide the Fabtech radius arm mount into the factory pocket with the frame tab facing the front of the truck. **SEE FIGURE 38**

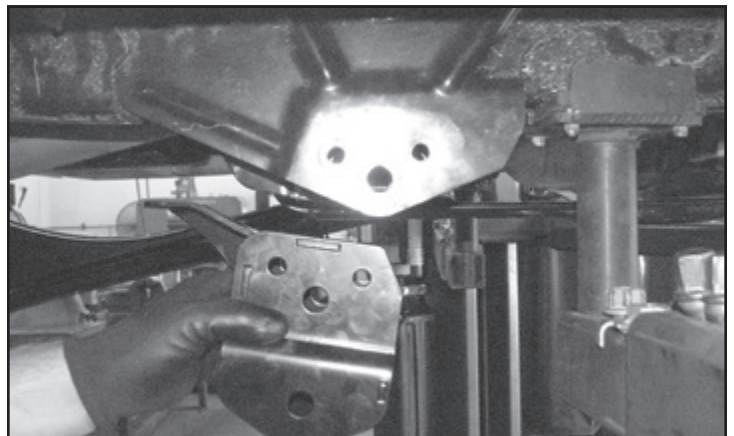

FIGURE 38 - STEP 45

46. Locate four 1/2"-13 x 1-1/4" bolts, nuts and washers. Use these bolts to mount the radius arm drop bracket to the factory bracket. Leave loose at this time. **SEE FIGURE 39**



FIGURE 39 - STEP 46

47. Locate the M18-2.5 x 90MM bolt, nut and washers. Pass the 18mm bolt through the factory pivot hole into the FT604 sleeve. Torque the 18mm bolt to 200 ft-lbs and the four 1/2" bolts to 127 ft-lbs. **SEE FIGURES 40-42**



FIGURE 40 - STEP 47

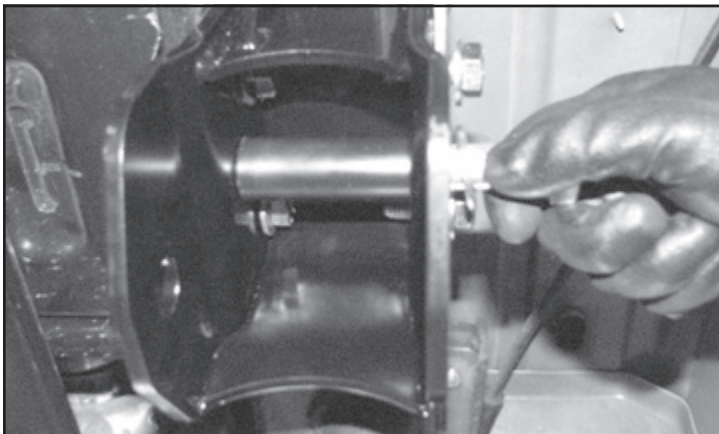

FIGURE 41 - STEP 47

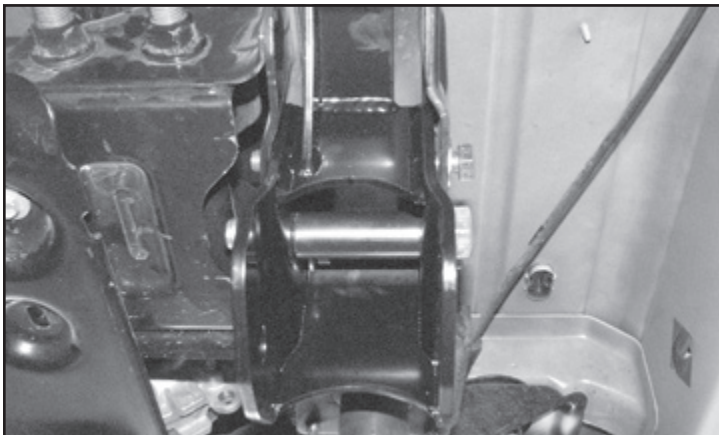

FIGURE 42 - STEP 47

48. Using the Fabtech the radius arm drop bracket as a drill guide, drill a 1/2" hole through the bottom of the frame. **SEE FIGURE 43**

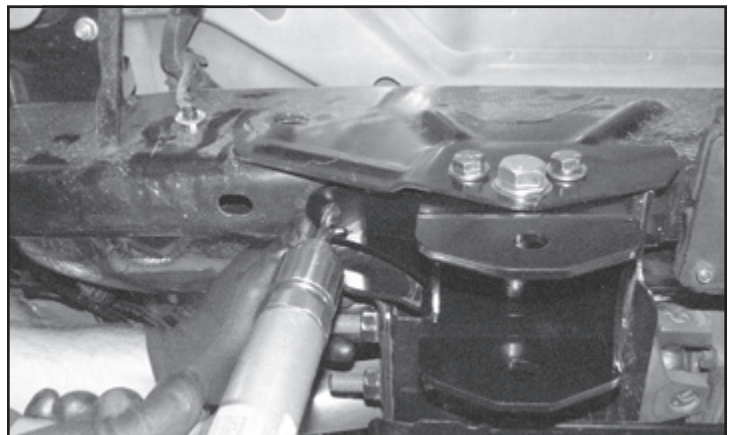

FIGURE 43 - STEP 48

49. Locate a 1/2"-13 x 1-1/4" bolt and the FT44253 nut tab. Pass the nut tab through the hole in the frame forward of the radius arm drop bracket. Connect the bolt and the nut tab through the radius arm drop bracket and the frame. **SEE FIGURES 44-46**

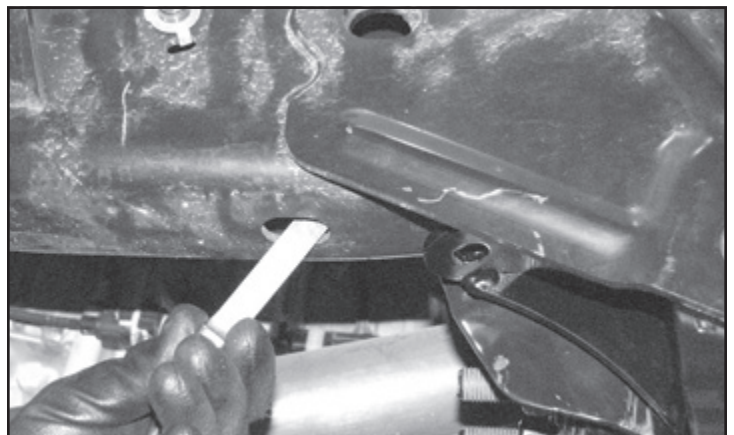

FIGURE 44 - STEP 49

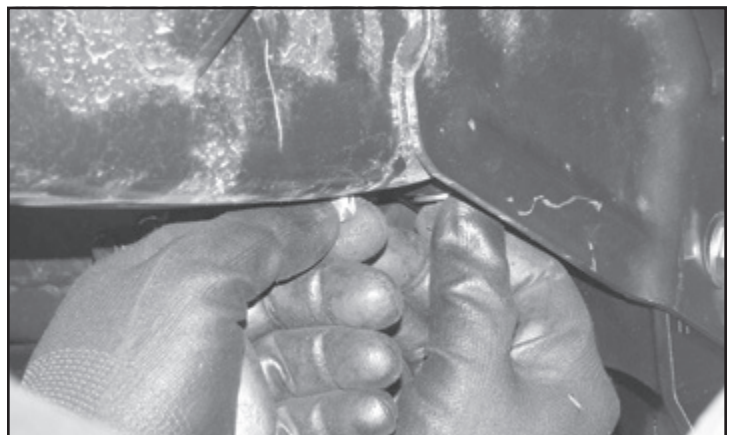

FIGURE 45 - STEP 49

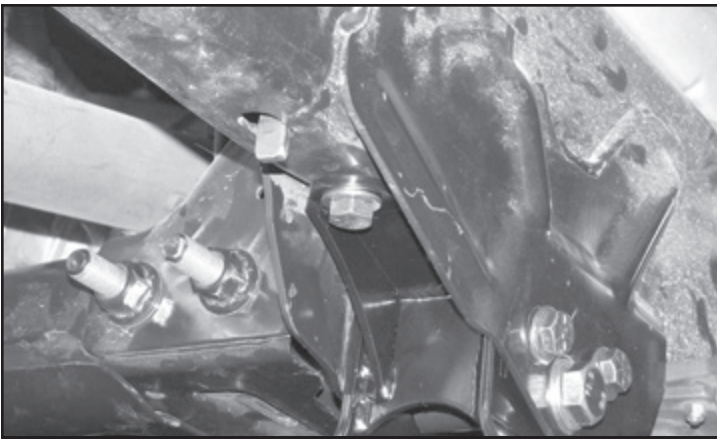

FIGURE 46 - STEP 49

REPEAT STEPS 45- 49 ON THE PASSENGER SIDE

50. Reinstall the factory radius arms with the factory hardware and torque to 200 ft-lbs. **SEE FIGURES 47-50**

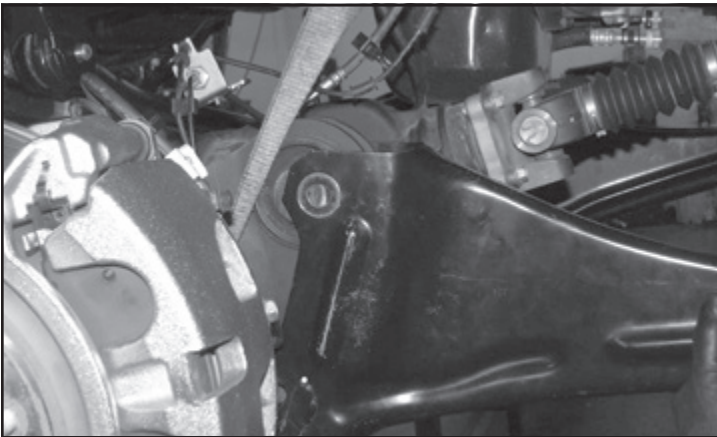

FIGURE 47 - STEP 50

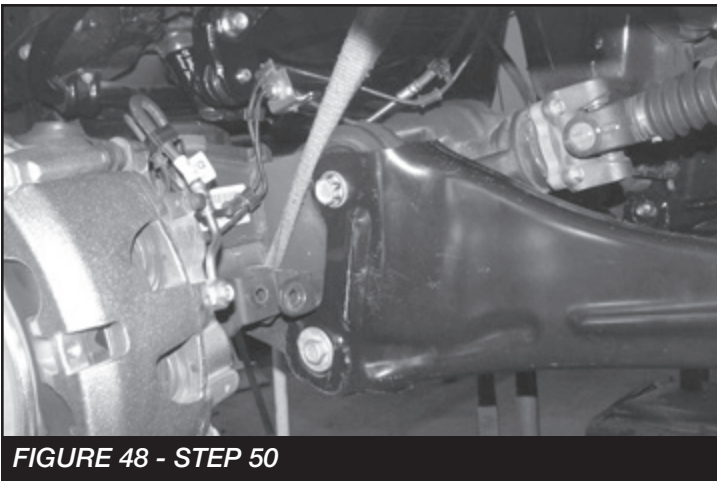

FIGURE 48 - STEP 50

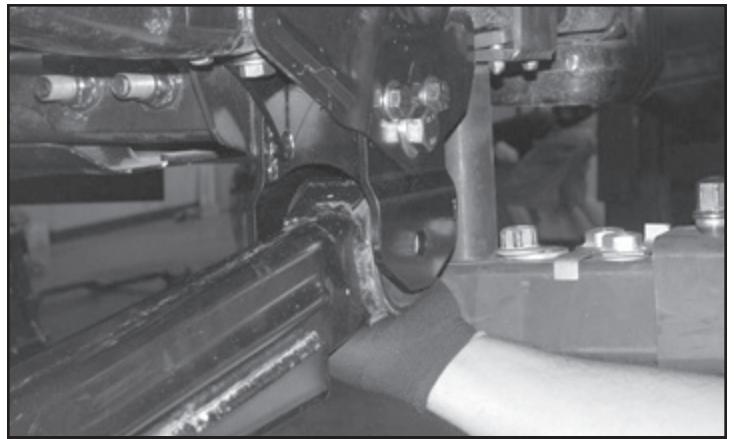

FIGURE 49 - STEP 50

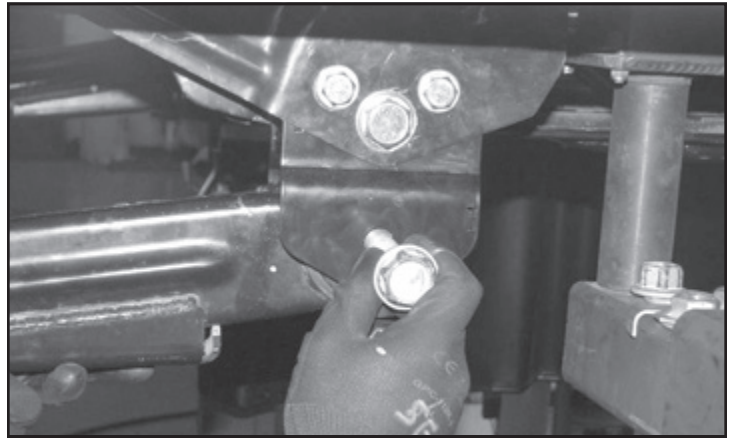

FIGURE 50 - STEP 50

IF INSTALLING FABTECH RADIUS ARMS FOLLOW STEPS 51-56

51. Remove the driver side factory radius arms and discard. Save the factory hardware. **SEE FIGURES 51-52**

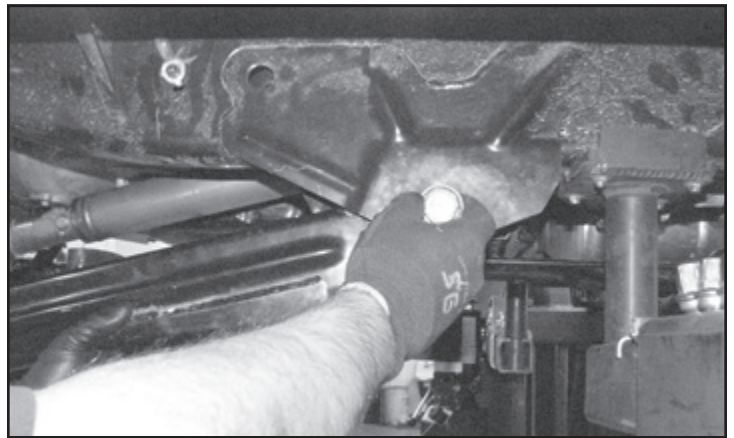

FIGURE 51 - STEP 51

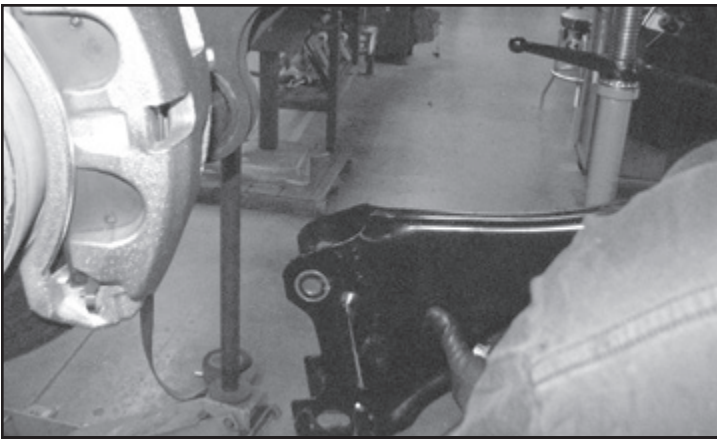

FIGURE 52 - STEP 51

52. Locate the FT44230BK Driver side radius arm, FT1006 bushing, FT102 sleeve, and zerk fitting.

53. Install two bushings, one sleeve, and the zerk fitting into the barrel of the radius arm. **SEE FIGURES 53-55**

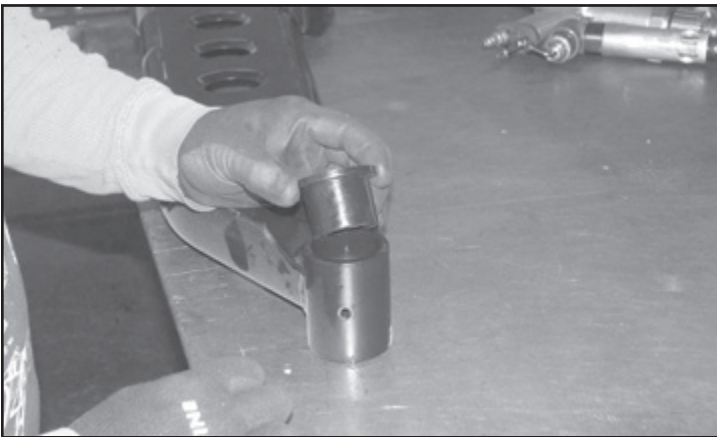

FIGURE 53 - STEP 53



FIGURE 54 - STEP 53

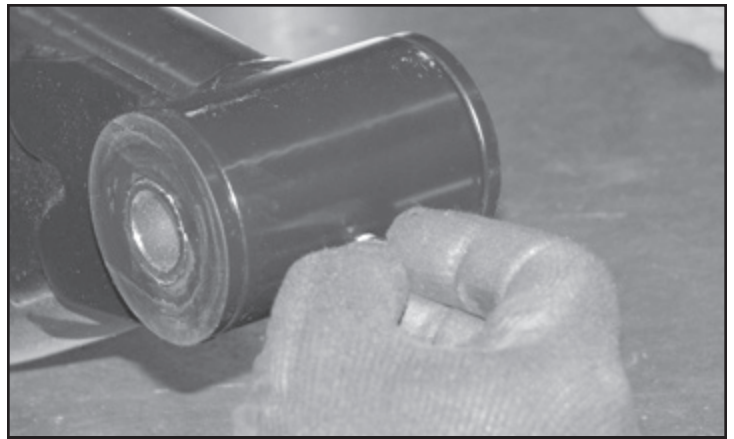

FIGURE 55 - STEP 53

54. Install the new Fabtech radius arms into the factory frame pocket and onto the axle bushings using the factory hardware. Torque the factory bolts to 200 ft-lbs. **SEE FIGURES 56-58**

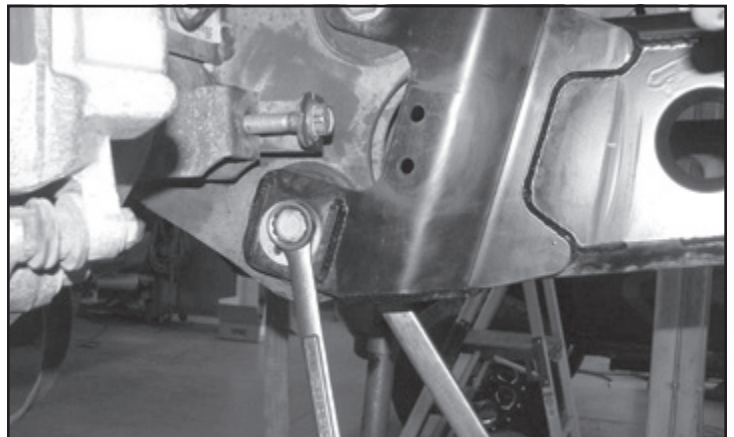

FIGURE 56 - STEP 54

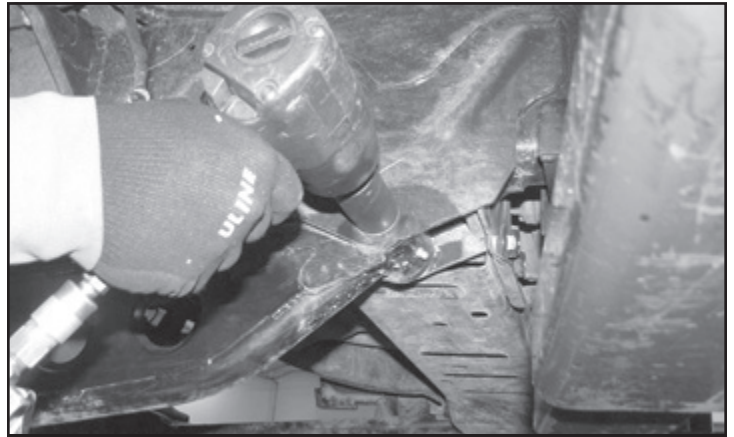

FIGURE 57 - STEP 54

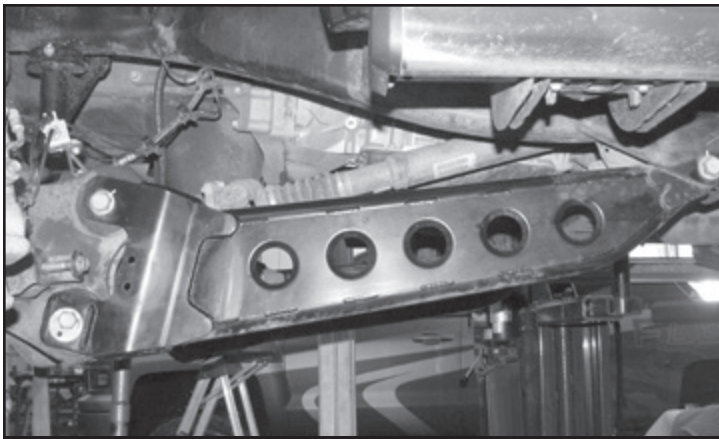

FIGURE 58 - STEP 54

55. Locate the factory coil spring isolator and slide it over the Fabtech coil spacer. Install the factory coil spring onto the Fabtech coil spacer and into the lower perch on the axle.

REPEAT STEPS 51-55 ON PASSENGER SIDE

56. Locate the FT44245 Brake line extension, FT44258 nut tab and two 1/4"-20 x 1" bolts. Attach the brake line extension to the axle using one bolt and the nut tab. Attach the factory brake line bracket to the Fabtech extension. Torque to 10 ft-lbs. Repeat this step on the passenger side. **SEE FIGURES 59-61**

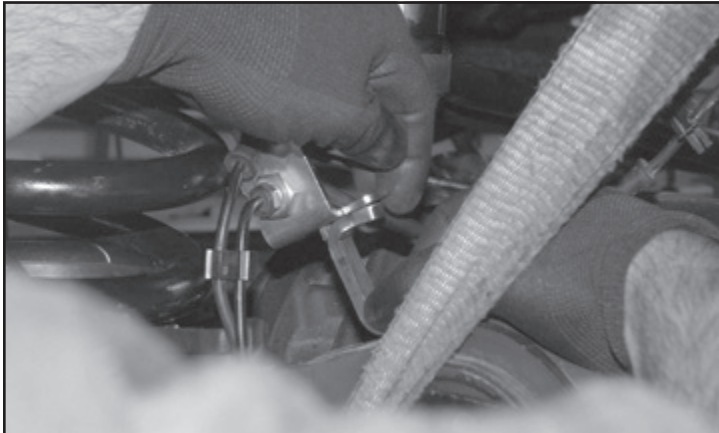

FIGURE 59 - STEP 56

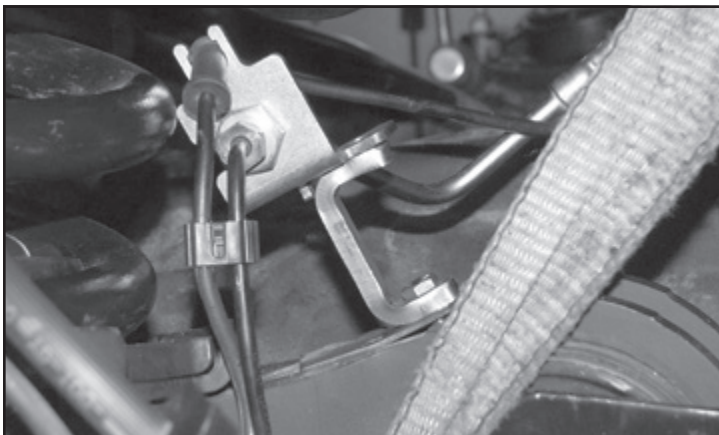

FIGURE 60 - STEP 56

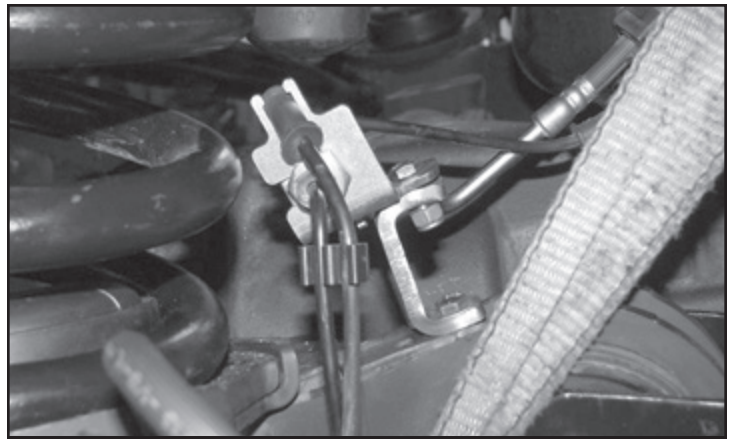

FIGURE 61 - STEP 56

57. Locate the FTS7343 Performance shock or the FTS811032 Dirt Logic shock and install into the factory shock mounts. Torque the upper mount to 14 ft-lbs and the lower 37 ft-lbs. **SEE FIGURES 62-63**

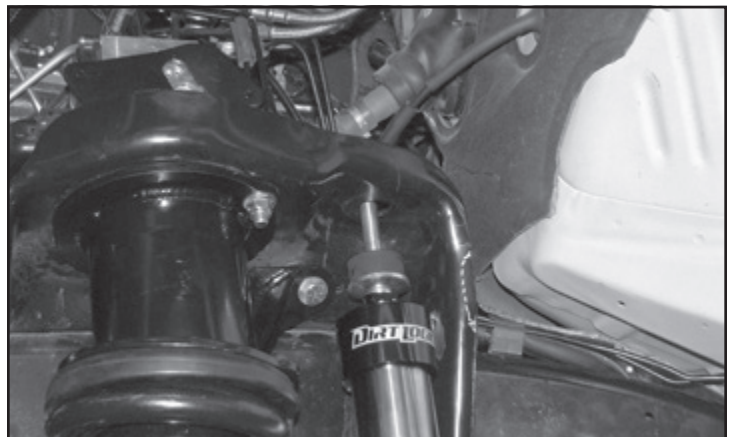

FIGURE 62 - STEP 57

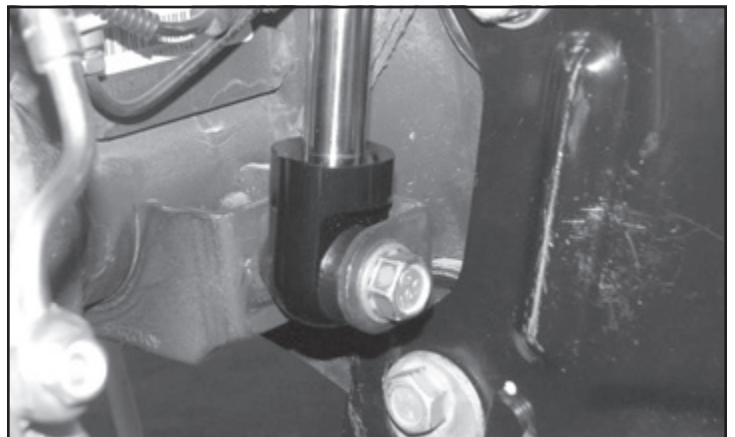

FIGURE 63 - STEP 57

58. Reconnect the factory sway bar. Torque to 29 ft-lbs.

SEE FIGURE 64

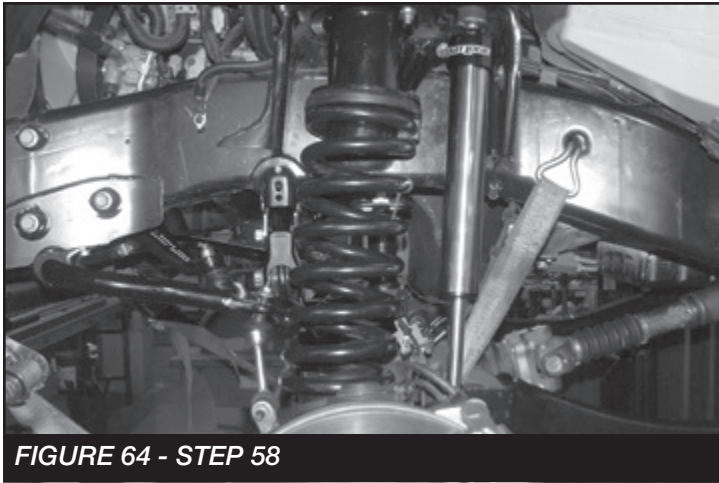

FIGURE 64 - STEP 58

REAR SUSPENSION

59. Jack up the rear end of the vehicle and support the frame rails with jack stands. Supporting the rear differential, remove and discard the rear shocks and u-bolts. Lower the axle down slowly. Use care not to over extend the brake hoses. **SEE FIGURES 65-66**

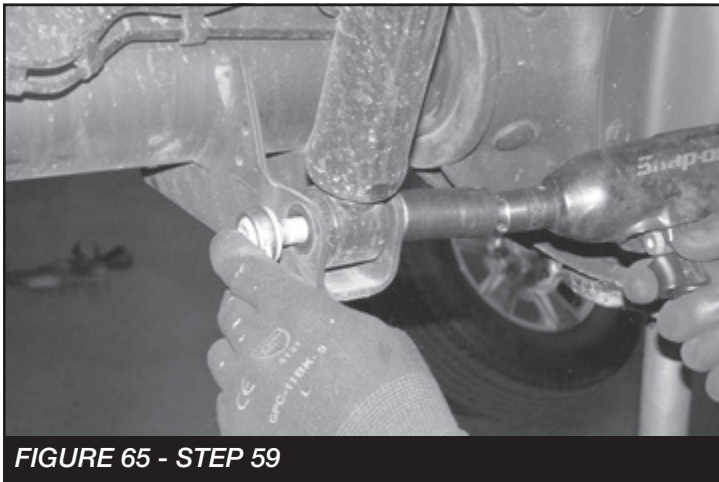

FIGURE 65 - STEP 59

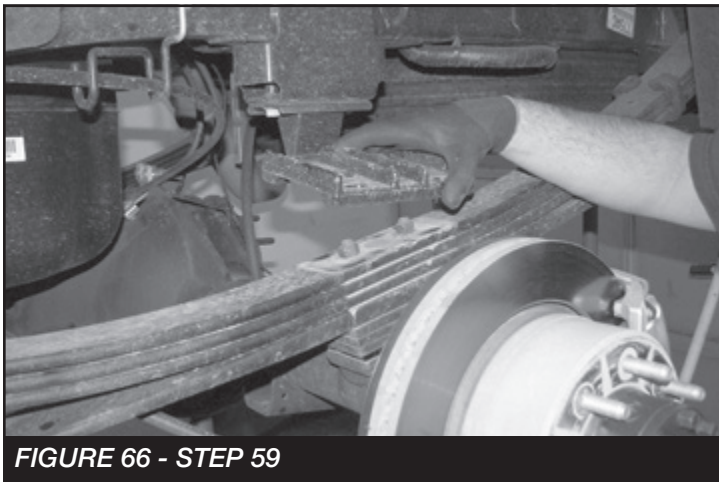

FIGURE 66 - STEP 59

60. Locate the supplied 2" blocks FTBK21, FT738U u-bolts and the FT916H hardware. Install the block onto the axle with the small end of the taper to front of the truck. Using the supplied u-bolts, nuts and washers, align axle, lift block and springs and torque to u-bolts to 129 ft-lbs. **SEE FIGURES 67-70**

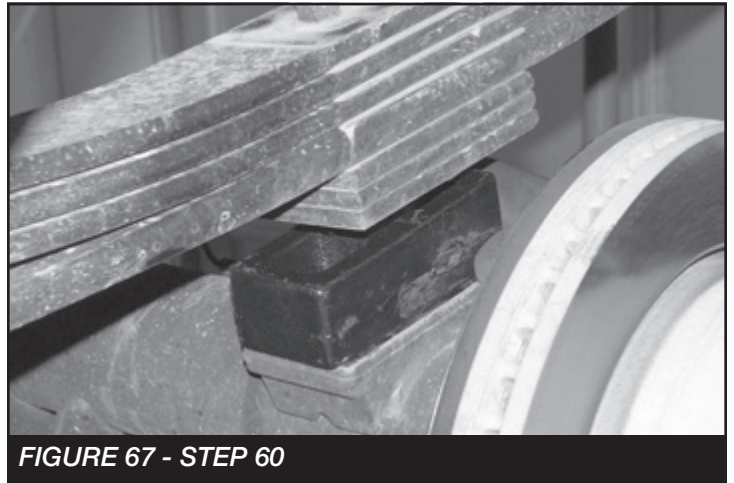

FIGURE 67 - STEP 60



FIGURE 68 - STEP 60



FIGURE 69 - STEP 60

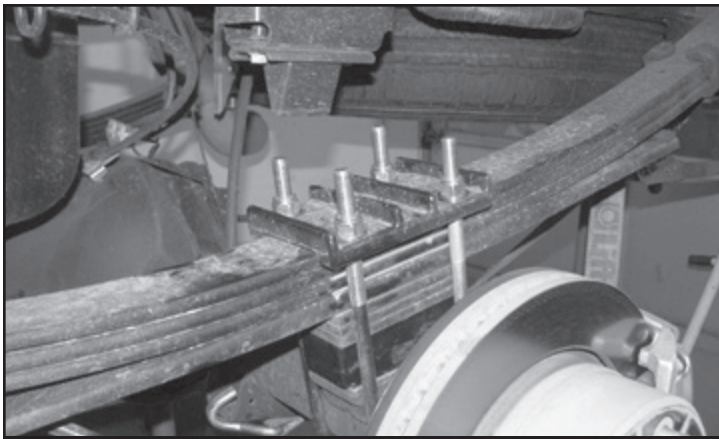

FIGURE 70 - STEP 60

61. Install new Fabtech Performance shocks FTS7335 or Dirt Logic 2.25" FTS810362 with the factory hardware and torque upper and lower bolts to 29 ft-lbs.
62. Locate the FT44242BK bump stop extension. Remove driver and passenger factory bump stop. Retain Hardware.
63. Install the bump stop extension to the factory mount using the factory hardware and torque to 65 ft-lbs.
SEE FIGURE 71

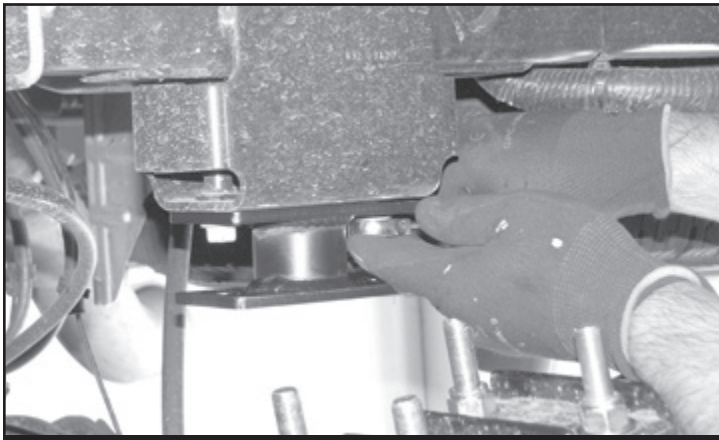

FIGURE 71 - STEP 63

64. Using 7/16"-14 x 1-1/4" bolt, nuts and washers, mount the factory bump stop to the extension. Torque to 59 ft-lbs. **SEE FIGURES 72-73**

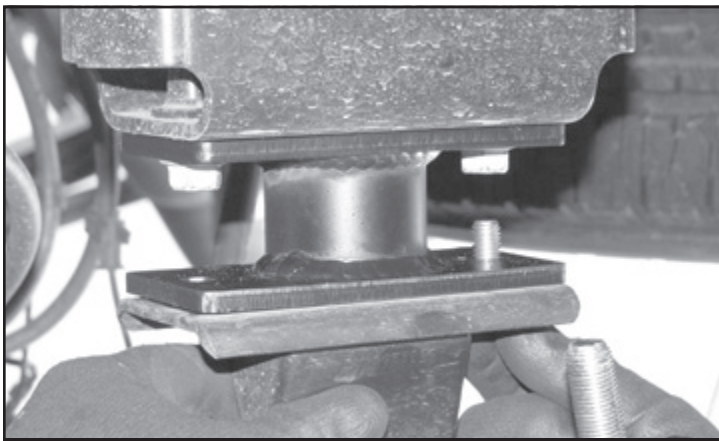

FIGURE 72 - STEP 64

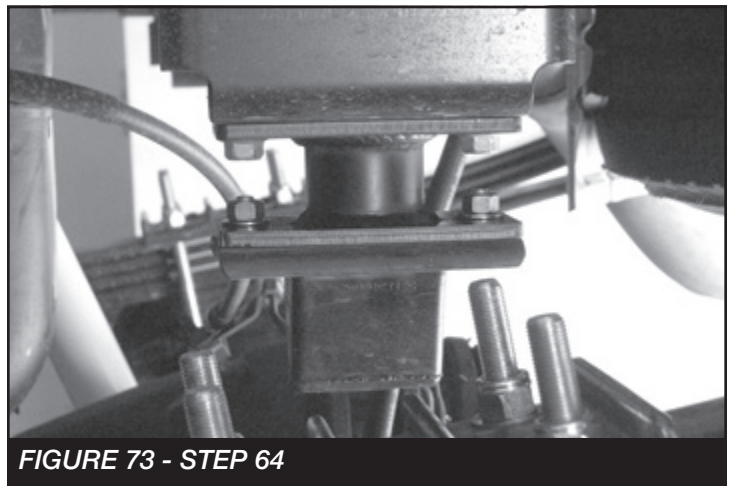

FIGURE 73 - STEP 64

65. Install tires and wheels and torque lug nuts to wheel manufacturer's specifications. Turn front tires left to right and check for appropriate tire clearance. **Note - Some oversized tires may require trimming of the front bumper & valance.**
66. Check front end alignment and set to factory specifications. Readjust headlights.
67. Recheck all bolts for proper torque.
68. Recheck brake hoses, ABS wires and suspension parts for proper tire clearance while turning tires fully left to right.
69. Check the fluid in the front and rear differential and fill if needed with factory specification differential oil. **Note - some differentials may expel fluid after filling and driving. This can be normal in resetting the fluid level with the new position of the differential/s.**
70. Install Driver Warning Decal. Complete product registration card and mail to Fabtech in order to receive future safety and technical bulletins on this suspension.

Vehicles that will receive oversized tires should check ball joints, uniballs and all steering components every 2500-5000 miles for wear and replace as required.

RETORQUE ALL NUTS, BOLTS AND LUGS AFTER 50 MILES AND PERIODICALLY THEREAFTER.

FT44232 - TEMPLATE

PRINT AT 100% - DO NOT SCALE TO PAGE

