



INSTALLATION INSTRUCTIONS



**2014-2020 FORD F150 2WD/4WD
0-6" UNIBALL UPPER CONTROL ARMS**

FTS22182



- PARTS LIST -

	FTS22182	0-6" F150 UNIBALL UCA KIT
1	FT30613BK	UCA DRIV ASSMBLD
1	FT30614BK	UCA PASS ASSMBLD
1	FT30615	HARDWARE SUBASSEMBLY

	FT90121	HARDWARE KIT
2	56180004152	9/16" -18 C LOCK NUT
2	56000005052	9/16 SAE WASHER G5 ZINC
2	75160004152	3/4-16 C-LOCK NUT ZINC

	FT30615	HARDWARE SUBASSEMBLY
1	FT90121	HARDWARE KIT
4	FT147	MISALIGNMENT
4	FT195	SLEEVE 1.000 X .563 X 2.450
8	FT1007	BUSHING BLACK URETHANE
4	FT84	GREASE FITTING 1/4-28
2	FT94504	UNIBALL ADAPTER PIN
2	FT22182I	INSTRUCTIONS
1	FTLUBE	URETHANE LUBE 1 PACKET
1	FTLOCK	THREAD LOCKING COMPOUND 1 MIL
4	12008007100	ZIP TIE 8" BLACK 40 LBS
1	FTAS12	STICKER FT BLUE 10X4
1	FTAS16	DRIVER WARNING DECAL
1	FTREGCARD	REGISTRATION CARD

- TOOL LIST -

Required Tools (Not Included)

- Basic Hand Tools
- Floor Jack
- Jack Stands
- Assorted Metric and S.A.E sockets, and Allen wrenches
- Torque Wrench

- PRE-INSTALLATION NOTES -

Read this before you begin installation-

Check all parts to the parts list above before beginning installation. If any parts are missing contact Fabtech at 909-597-7800 and a replacement part will be sent to you immediately.

Read all instructions thoroughly from start to finish before beginning the installation. If these instructions are not properly followed severe frame, driveline and / or suspension damage may occur.

Check your local city and state laws prior to the installation of this system for legality. Do not install if not legal in your area.

Prior to the installation of this suspension system perform a front end alignment and record. Do not install this system if the vehicle alignment is not within factory specifications. Check for frame and suspension damage prior to installation.

The installation of this suspension system should be performed by two professional mechanics.

Use the provided thread locking compound on all hardware.

WARNING- Installation of this system will alter the center of gravity of the vehicle and may increase roll over as compared to stock.

NOTE: Will not work with factory wheels. Must use wheels w/ 5" BS with minor trimming.

- INSTRUCTIONS -

1. Disconnect the negative terminal on the battery. Jack up the front end of the truck and support the frame rails with jack stands. **NEVER WORK UNDER AN UNSUPPORTED VEHICLE!** Remove the front tires.
2. Starting on the drivers side remove the upper ball joint nut. Disconnect the upper ball joint from the knuckle by striking the knuckle with a large hammer next to the upper ball joint on the knuckle to dislodge the ball joints. Use care not to hit the ball joints when removing.
3. Remove the upper control arm and retain the factory hardware. **SEE FIGURE 1**

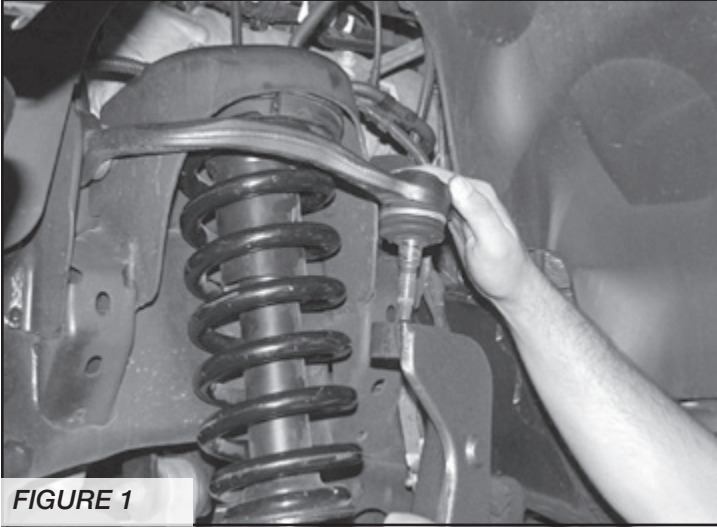

FIGURE 1

4. Locate the Fabtech driver's side control arm FT30613BK, four bushings FT1007, two grease zerks FT84 and two sleeves FT195.
5. Install all these components in the control arm barrels. **SEE FIGURE 2**

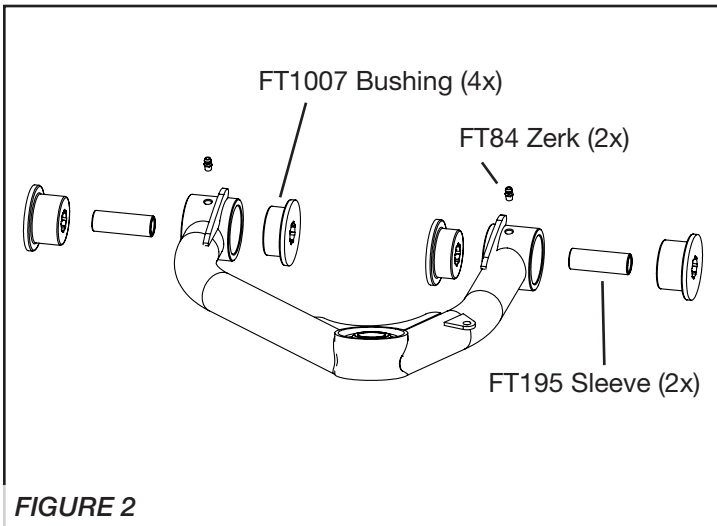

FIGURE 2

6. Install the new Fabtech upper control arm in the factory upper control arm pockets using the factory hardware. When installing the arm on the truck make sure the barrel gussets are up. Torque to 100 ft- lbs.
7. Locate FT94504 Uniball adapter pin, and two FT147 uniball misalignment spacers.

SEE FIGURE 3 FOR STEPS 8-12

8. Insert the uniball pin into the factory knuckle upper ball joint taper. Install the 9/16"-18 lock nut with thread lock compound and flat washer onto the bottom side of the pin. This will lock the pin into the knuckle. Torque to 150 ft-lbs.
9. Install one FT147 uniball misalignment spacer on to the pin.
10. Swing the control arm down, slide the pin into the uniball on the control arm seating the lower FT147 spacer in the control arm.
11. Install the upper FT147 uniball misalignment spacer onto the pin.
12. Install the 3/4" -16 lock nut on the top side of the pin with thread lock compound and torque to 150 ft-lbs.

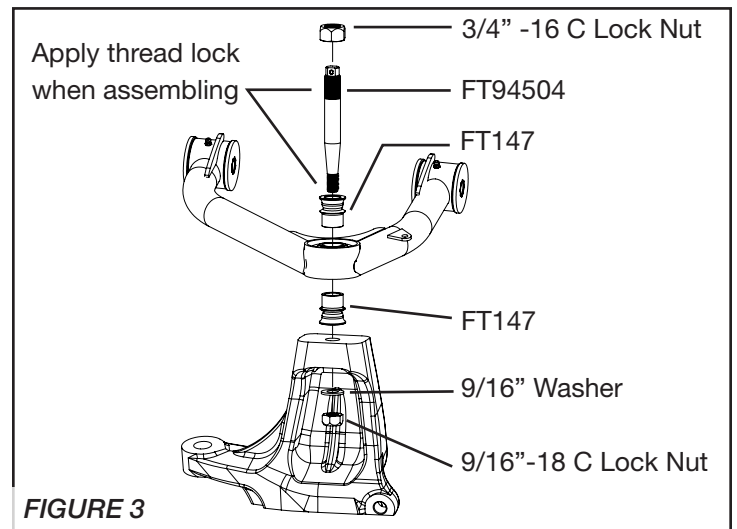

FIGURE 3

13. Repeat 2-12 on the passenger side of the vehicle.
14. Install tires and wheels and torque lug nuts to wheel manufacturer's specifications. Turn front tires left to right and check for appropriate tire clearance. **Note - Some oversized tires may require trimming of the front bumper & valance.**
15. Check front end alignment and set to factory specifications. Readjust headlights.
16. Recheck all bolts for proper torque.
17. Recheck brake hoses, ABS wires and suspension parts for proper tire clearance while turning tires fully left to right.

18. Install Driver Warning Decal. Complete product registration card and mail to Fabtech in order to receive future safety and technical bulletins on this suspension.

Vehicles that will receive oversized tires should check ball joints and all steering components every 2500-5000 miles for wear and replace as required.

RETORQUE ALL NUTS, BOLTS AND LUGS AFTER 50 MILES AND PERIODICALLY THEREAFTER.

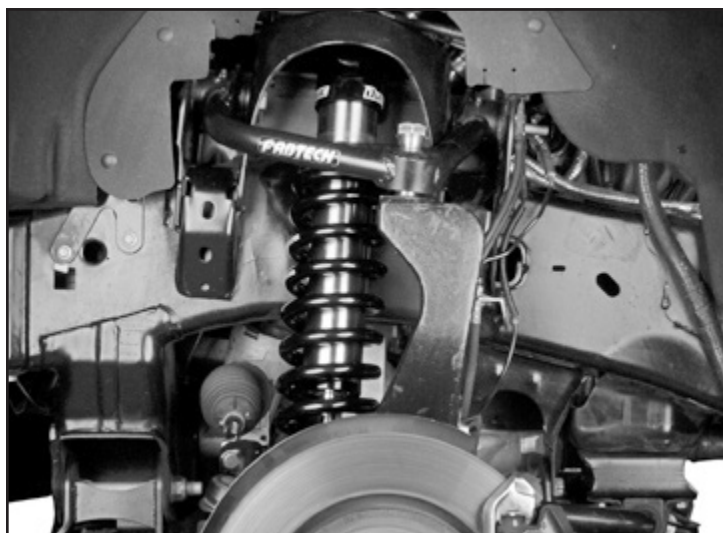

FINISHED INSTALL ON 6" FABTECH SYSTEM