



INSTALLATION INSTRUCTIONS



**2009-13 FORD F150 4WD
0-6" UNIBALL UPPER CONTROL ARMS**

FTS22159



- PARTS LIST -

	FTS22159	0-6" F150 UNIBALL UCA KIT
1	FT30507BK	UCA DRIV ASSMBLD
1	FT30508BK	UCA PASS ASSMBLD
1	FT30511	HARDWARE SUBASSEMBLY

	FT90121	HARDWARE KIT
2	56180004152	9/16" -18 C LOCK NUT
2	56000005052	9/16 SAE WASHER G5 ZINC
2	75160004152	3/4-16 C-LOCK NUT ZINC

	FT30511	HARDWARE SUBASSEMBLY
1	FT90121	HARDWARE KIT
4	FT147	MISALIGNMENT
4	FT195	SLEEVE 1.000 X .563 X 2.450
8	FT1007	BUSHING BLACK URETHANE
4	FT84	GREASE FITTING 1/4-28
2	FT94504	UNIBALL ADAPTER PIN
2	FT22159I	INSTRUCTIONS
1	FTLUBE	URETHANE LUBE 1 PACKET
1	FTLOCK	THREAD LOCKING COMPOUND 1 MIL
4	12008007100	ZIP TIE 8" BLACK 40 LBS

- TOOL LIST -

Required Tools (Not Included)

- Basic Hand Tools
- Floor Jack
- Jack Stands
- Assorted Metric and S.A.E sockets, and Allen wrenches
- Torque Wrench

- PRE-INSTALLATION NOTES -

Read this before you begin installation-

Check all parts to the parts list above before beginning installation.

Read all instructions thoroughly from start to finish before beginning the installation. If these instructions are not properly followed severe frame, driveline and / or suspension damage may occur.

Check your local city and state laws prior to the installation of this system for legality. Do not install if not legal in your area.

Prior to the installation of this suspension system perform a front end alignment and record. Do not install this system if the vehicle alignment is not within factory specifications. Check for frame and suspension damage prior to installation.

The installation of this suspension system should be performed by two professional mechanics.

Use the provided thread locking compound on all hardware.

WARNING- Installation of this system will alter the center of gravity of the vehicle and may increase roll over as compared to stock.

NOTE: Will not work with factory wheels. Must use wheels w/ 5" BS with minor trimming.

- INSTRUCTIONS -

1. Disconnect the negative terminal on the battery. Jack up the front end of the truck and support the frame rails with jack stands. **NEVER WORK UNDER AN UNSUPPORTED VEHICLE!** Remove the front tires.
2. Starting on the drivers side remove the upper ball joint nut. Disconnect the upper ball joint from the knuckle by striking the knuckle with a large hammer next to the upper ball joint on the knuckle to dislodge the ball joints. Use care not to hit the ball joints when removing.
3. Remove the upper control arm and retain the factory hardware. **SEE FIGURE 1**

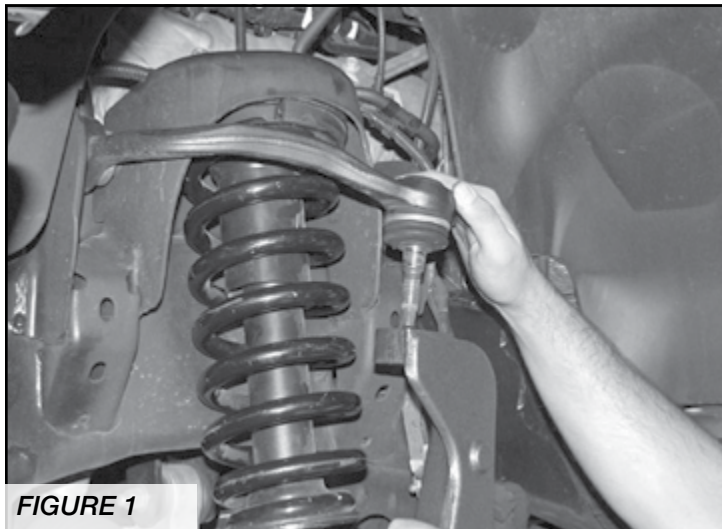

FIGURE 1

4. Locate the Fabtech driver's side control arm FT30507BK, four bushings FT1007, two grease zerks FT84 and two sleeves FT195.
5. Install all these components in the control arm barrels. **SEE FIGURE 2**

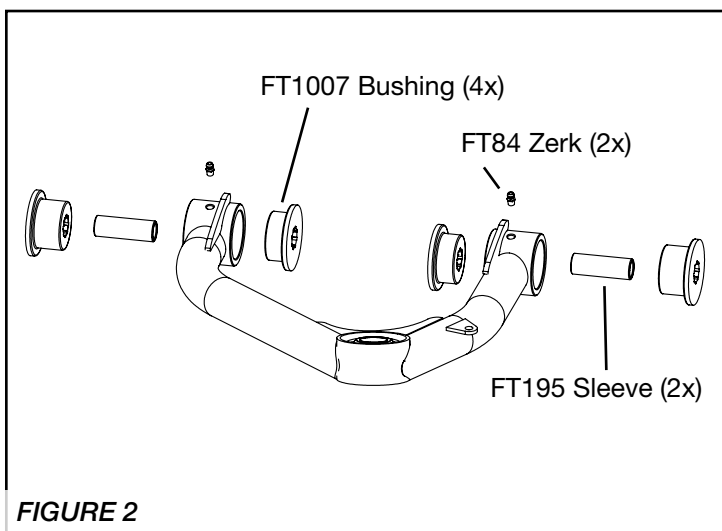

FIGURE 2

6. Install the new Fabtech upper control arm in the factory upper control arm pockets using the factory hardware. When installing the arm on the truck make sure the barrel gussets are up. Torque to 100 ft- lbs.
7. Locate FT94504 Uniball adapter pin, and two FT147 uniball misalignment spacers.

SEE FIGURE 3 FOR STEPS 8-12

8. Insert the uniball pin into the factory knuckle upper ball joint taper. Install the 9/16"-18 lock nut with thread lock compound and flat washer onto the bottom side of the pin. This will lock the pin into the knuckle. Torque to 150 ft-lbs.
9. Install one FT147 uniball misalignment spacer on to the pin.
10. Swing the control arm down, slide the pin into the uniball on the control arm seating the lower FT147 spacer in the control arm.
11. Install the upper FT147 uniball misalignment spacer onto the pin.
12. Install the 3/4" -16 lock nut on the top side of the pin with thread lock compound and torque to 150 ft-lbs.

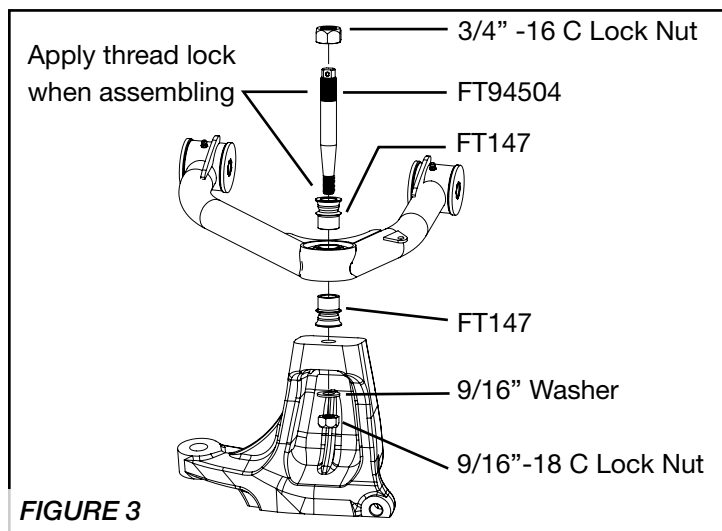

FIGURE 3

13. Repeat 2-12 on the passenger side of the vehicle.
14. Install tires and wheels and torque lug nuts to wheel manufacturer's specifications. Turn front tires left to right and check for appropriate tire clearance. **Note - Some oversized tires may require trimming of the front bumper & valance.**
15. Check front end alignment and set to factory specifications. Readjust headlights.
16. Recheck all bolts for proper torque.
17. Recheck brake hoses, ABS wires and suspension parts for proper tire clearance while turning tires fully left to right.

18. Install Driver Warning Decal. Complete product registration card and mail to Fabtech in order to receive future safety and technical bulletins on this suspension.

Vehicles that will receive oversized tires should check ball joints and all steering components every 2500-5000 miles for wear and replace as required.

**RETORQUE ALL NUTS, BOLTS AND LUGS
AFTER 50 MILES AND PERIODICALLY
THEREAFTER.**

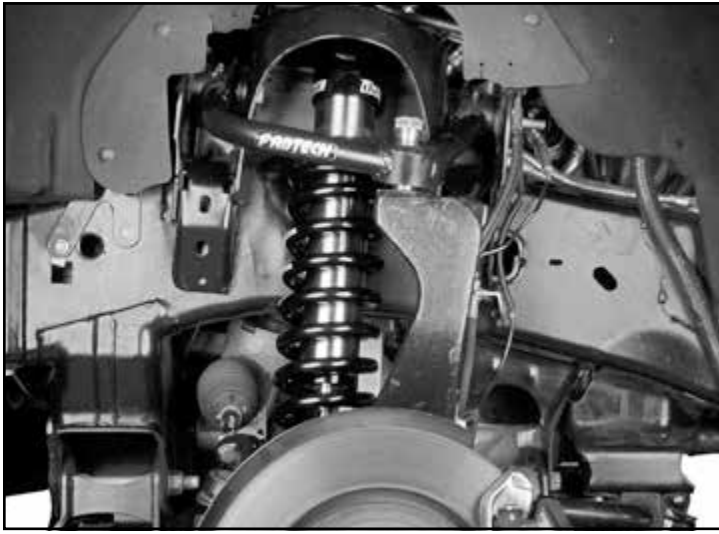

FINISHED INSTALL ON 6" FABTECH SYSTEM



FTS22189		2.5" Dirt Logic SS Coilover w/Resi
2	FT820302	DLSS Coilover w/Resi
1	FT30623	HARDWARE SUBASSEMBLY
1	FT83369BK	2.5 RESI MOUNT

FTS22190		2.5" Dirt Logic SS Coilover w/Resi
2	FT820242	DLSS Coilover w/Resi
1	FT30623	HARDWARE SUBASSEMBLY
1	FT83369BK	2.5 RESI MOUNT

FTS22191		2.5" Dirt Logic SS Coilover w/Resi
2	FT820232	DLSS Coilover w/Resi
1	FT30623	HARDWARE SUBASSEMBLY
1	FT83369BK	2.5 RESI MOUNT

FT30623		HARDWARE SUBASSEMBLY
2	FT30112	MISALIGNMENT (FRONT)
2	FT83309	MISALIGNMENT LOWER
2	FT83310	MISALIGNMENT LOWER
1	FT86053	HARDWARE KIT
1	FT820232i	INSTRUCTIONS

Thank you for purchasing Dirt Logic shocks, the finest off-road shock in the industry. Each unit is built to exacting standards and is properly tuned specifically for your vehicle. Dirt Logic shocks are designed and built to both beautify and upgrade your suspension system.

How To Care For Your Dirt Logic Shocks

Dirt Logic shocks have been designed as a take apart, serviceable, race style unit. That means, just like a race shock, it will need to be maintained and periodically rebuilt. The tight tolerances of this provide the exceptional ride and performance you are paying for but do require maintenance which is normal in a take apart shock like a Dirt Logic.

Externally, the shock should be kept clean at all times and kept free of dirt, road salt or other corrosive elements. The unit should be routinely washed with a pH balanced cleaner to keep the finish looking new. Do not use any abrasive or aggressive cleaners or degreasers as it will harm the finish for life including the aluminum anodizing.

Internally, the shock has high performance seals that allow the shock to cycle at very high rates and provide exceptional damping in aggressive off-road conditions. These seals are a wearable item and may need to be replaced periodically to keep the shock functioning correctly. Our in house Shock Lab is equipped to handle these needs when necessary.

Caution – Read Before Installing

Stop – Call FABTECH customer service if any component of this product is missing.

This Dirt Logic Shock is shipped pressurized with Nitrogen. Do not remove tamper cap or warranty will be void.

If this shock is equipped with a reservoir hose, do not loosen or remove the hose or warranty will be void.

If this shock is equipped with a coil, be aware that the coil has some amount of preload from the factory and should not be removed. Removal of the coil will void the warranty.

If this shock product needs to be returned for any reason, it must be returned in its original packaging or warranty will be void.

Dirt Logic Shocks come with a one year warranty from the original date of purchase for defects in material or workmanship.

A spanner wrench can be purchased for future adjustment. (FTS89905 for 4.0 and FTS98008 for 2.5)

- INSTRUCTIONS -

FRONT SUSPENSION

1. Working from the driver side of the truck, locate one of the new Fabtech adjustable coil over's, using the supplied 3/8" bolts and washers attach the upper mounting plate to the factory upper coil seat. Torque to 35 ft. lbs.
2. Locate one of each of the supplied FT30112 & FT83309 & FT83310 Mis-Alignments, and 5/8" bolt, nut, and washers. Attach the shock to the lower control arm as shown in the drawing below. The FT30112 is the wider Mis-alignment and should be installed on the side of the shock that faces the front of the truck. Torque to 100 ft. lbs. **SEE FIGURE 1**

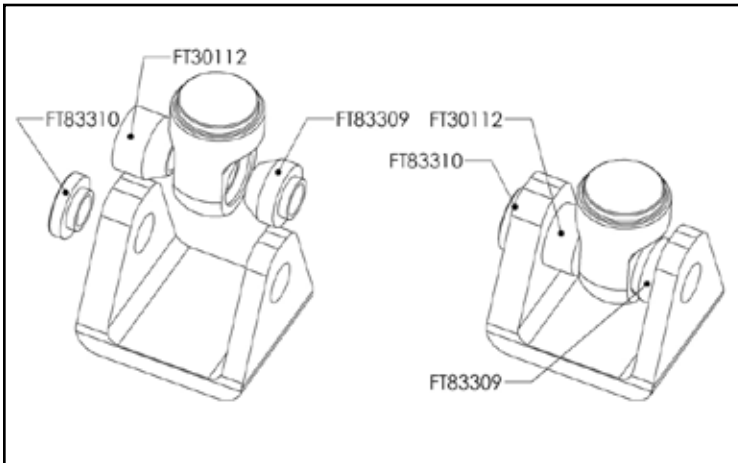

FIGURE 1 - STEP 2

3. Repeat steps two and three on the passenger side of the truck.
4. Next locate and mount the Resi mount (FT83369BK) to the frame using the supplied self tapping screws. **NOTE: Make sure you have enough slack in the hose before mounting the Resi mount.** Finally mount the Resi to the mount using the supplied clamps. **SEE FIGURES 2-3**

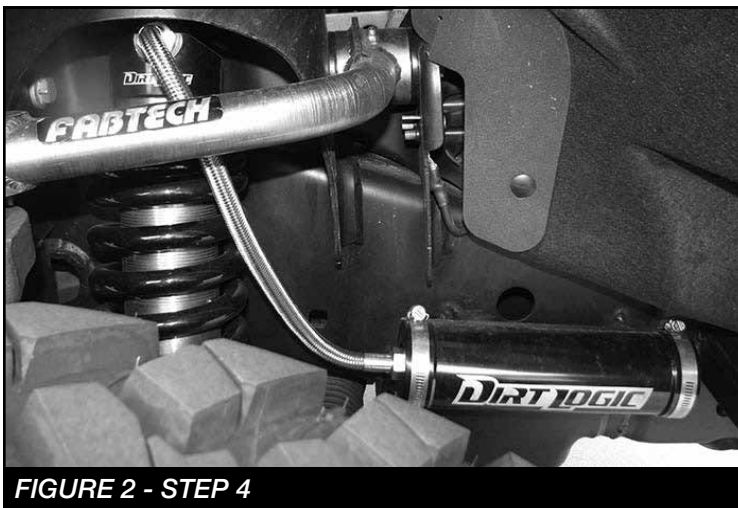

FIGURE 2 - STEP 4



FIGURE 3 - STEP 4

5. Refer back to the kit instructions to finish installation.
6. Check front end alignment and set to factory specifications. Readjust headlights.
7. Recheck all bolts for proper torque.
8. Recheck brake hoses, ABS wires and suspension parts for proper tire clearance while turning tires fully left to right.
9. Check the fluid in the front and rear differential and fill if needed with factory specification differential oil. **Note - some differentials may expel fluid after filling and driving. This can be normal in resetting the fluid level with the new position of the differential/s.**
10. Install Driver Warning Decal. Complete product registration card and mail to Fabtech in order to receive future safety and technical bulletins on this suspension.

Vehicles that will receive oversized tires should check ball joints, uniballs and all steering components every 2500-5000 miles for wear and replace as required.

RETORQUE ALL NUTS, BOLTS AND LUGS AFTER 50 MILES AND PERIODICALLY THEREAFTER.



	FTS810322	2.25 Dirt Logic Stainless Steel Shock
1	FTS810322	DLSS SHOCK
1	FT810322i	INSTRUCTIONS
1	FT86008	HARDWARE & BUSHING KIT 8
1	FT89900	STICKER

Thank you for purchasing Dirt Logic shocks, the finest off-road shock in the industry. Each unit is built to exacting standards and is properly tuned specifically for your vehicle. Dirt Logic shocks are designed and built to both beautify and upgrade your suspension system.

How To Care For Your Dirt Logic Shocks

Dirt Logic shocks have been designed as a take apart, serviceable, race style unit. That means, just like a race shock, it will need to be maintained and periodically rebuilt. The tight tolerances of this provide the exceptional ride and performance you are paying for but do require maintenance which is normal in a take apart shock like a Dirt Logic.

Externally, the shock should be kept clean at all times and kept free of dirt, road salt or other corrosive elements. The unit should be routinely washed with a pH balanced cleaner to keep the finish looking new. Do not use any abrasive or aggressive cleaners or degreasers as it will harm the finish for life including the aluminum anodizing.

Internally, the shock has high performance seals that allow the shock to cycle at very high rates and provide exceptional damping in aggressive off-road conditions. These seals are a wearable item and may need to be replaced periodically to keep the shock functioning correctly. Our in house Shock Lab is equipped to handle these needs when necessary.

Caution – Read Before Installing

Stop – Call FABTECH customer service if any component of this product is missing.

This Dirt Logic Shock is shipped pressurized with Nitrogen. Do not remove tamper cap or warranty will be void.

If this shock is equipped with a reservoir hose, do not loosen or remove the hose or warranty will be void.

If this shock is equipped with a coil, be aware that the coil has some amount of preload from the factory and should not be removed. Removal of the coil will void the warranty.

If this shock product needs to be returned for any reason, it must be returned in its original packaging or warranty will be void.

Dirt Logic Shocks come with a one year warranty from the original date of purchase for defects in material or workmanship.

A spanner wrench can be purchased for future adjustment. (FTS89905 for 4.0 and FTS98008 for 2.5)

Should you have any questions regarding your Dirt Logic Shocks, please feel free to contact us.

Installation Instructions

Install the bushing kit onto the 2.25" Dirt Logic Shock included in the packaging. Now install the shock by attaching the top cap first and the rod end second. Take care to compress the shock when installing the rod end as the shock is under pressure and will require leverage and strength to accomplish this task. This would be best done with the vehicle on a hoist with the suspension at its most extended length. Once the shock is installed tighten the bolts until there is a light squeeze on the urethane bushings.

(Note some 2.25" shocks will require extra components to be installed prior to shock installation)

- Product Warranty and Warnings -

Fabtech provides a Limited Lifetime Warranty to the original retail purchaser who owns the vehicle, on which the product was originally installed, for defects in workmanship and materials.

The Limited Lifetime Warranty excludes the following Fabtech items; bushings, bump stops, ball joints, tie rod ends, limiting straps, cross shafts, heim joints and driveshafts. These parts are subject to wear and are not considered defective when worn. They are warranted for 60 days from the date of purchase for defects in workmanship.

Dirt Logic and Performance Coilover take apart shocks are considered a serviceable shock with a one year warranty on leakage only. Service seal kits are available separately for future maintenance. All other shocks are covered under our Limited Lifetime Warranty.

Fabtech does not warrant any product for finish, alterations, modifications and/or installation contrary to Fabtech's instructions. Alterations to the finish of the parts including but not limited to painting, powder coating, plating and/or welding will void all warranties. Some finish damage may occur to parts during shipping, which is considered normal and is not covered under warranty.

Fabtech products are not designed nor intended to be installed on vehicles used in race applications or for racing purposes or for similar activities. (A "RACE" is defined as any contest between two or more vehicles, or any contest of one or more vehicle against the clock, whether or not such contest is for a prize). This warranty does not include coverage for police or taxi vehicles, race vehicles, or vehicles used for government or commercial purposes. Also excluded from this warranty are sales outside of the United States of America.

Installation of most suspension products will raise the center of gravity of the vehicle and will cause the vehicle to handle differently than stock. It may increase the vehicle's susceptibility to a rollover, on road and off road, at all speeds. Extreme care should be taken to operate the vehicle safely at all times to prevent rollover or loss of control resulting in serious injury or death. Fabtech front end Desert Guards may impair the deployment or operation of vehicles equipped with supplemental restraining systems/air bag systems and should not be installed if the vehicle is equipped as so.

Fabtech makes every effort to ensure suspension product compatibility with all vehicles listed on the website, but due to unknown auto manufacturer's production changes and/or inconsistencies by the auto manufacturer, Fabtech cannot be responsible for 100% compatibility, including the fitment of tire and wheel sizes listed. The Tire and Wheel sizes listed in Fabtech's website are only a guideline for street driving with noted fender trimming. Fabtech is not responsible for damages to the vehicle's body or tires. Fabtech is not responsible for premature wear of factory components due to the installation of oversized tires and wheels.

Fabtech's obligation under this warranty is limited to the repair or replacement, at Fabtech option, of the defective product only. All costs of removal, installation or re-installation, freight charges, incidental or consequential damages are expressly excluded from this warranty. Fabtech is not responsible for damages and/or warranty of other vehicle parts related or non related to the installed Fabtech product. This warranty is expressly in lieu of all other warranties expressed or implied. This warranty shall not apply to any product that has been subject to accident, negligence, alteration, abuse or misuse as determined by Fabtech.

Fabtech suspension components must be installed as a complete system including shocks as shown on our website. All warranties will become void if Fabtech parts are combined and/or substituted with other aftermarket suspension products. Combination and/or substitution of other aftermarket suspension parts may cause premature wear and/or product failure resulting in an accident causing injury or death. Fabtech does not warrant products not manufactured by Fabtech.

Depending on the condition of the factory suspension components retained after the installation of a Fabtech suspension not all vehicles may have the same ride stance front to rear as described in the website. The blue color of suspension components shown in all Fabtech photographs are for display purposes only. Majority of all Fabtech components will be black specifically where noted with part numbers ending in BK.

Installation of Fabtech product may void the vehicles factory warranty; it is the consumer's responsibility to check with their local vehicle's dealer for warranty disposition before the installation of the product. Some state laws may prohibit modification of suspension to a vehicle in whole or in part. It is the responsibility of the installer and consumer to consult local laws prior to the installation of any Fabtech suspension product to comply with such written laws.