



INSTALLATION INSTRUCTIONS



2008-13 FORD F450/F550 10 LUG

6" BASIC SYSTEM

FTS22123 / FTS22147



- PARTS LIST -

2008-10 FORD F450/F550

	FTS22123BK	COMPONENT BOX 1
2	FT30467BK	Radius Arm Bracket Driver / Passenger
1	FT30342	Pitman Arm
1	FT30367	Hardware Sub-Assembly
1	FT30143BK	Front Bumpstop Drop (Driver)
1	FT30144BK	Front Bumpstop Drop (Passenger)
1	FT30402	Steering Stabilizer Drop
1	FT3400-112P	Sway Bar Drop Bracket (Driver)
1	FT3400-112D	Sway Bar Drop Bracket (Passenger)
1	FT30373BK	Trac Bar Drop Bracket
1	FT30273BK	Trac Bar Support Tube
2	FT30277BK	ABS Line Bracket @ Radius Arm
1	FT30285	Hardware Kit
1	FT30401	Hardware Sub-Assembly

	FT30367	HARDWARE SUB-ASSEMBLY
1	12175801012	M12x1.75 x 80mm Bolt
2	12000005412	M12 Washer
1	12175003012	M12x1075 Nut
1	FT30258	Sector Shaft Nut
2	FT30409	8" Brake Line
2	FT30410	Brake Line Union
1	FT30276	Front Brake line Bracket (Passenger)
1	FT30348	Front Brake line Bracket (Driver)
1	FTREGCARD	Reg. Card
1	FTAS12	Fabtech Sticker
2	FT22123i	Instruction Sheet

	FT30401	HARDWARE SUB-ASSEMBLY
1	FT104	Sleeve Tapered S/D
1	FT179	Sleeve Stabilizer
1	FT30403	Clevis
1	50132501052	1/2-13 X 2 1/2" Hex Bolt
2	50130004152	Nut 1/2-13 Crimp Lock
3	50000005052	Washer 1/2 SAE
1	50131751052	1/2-13 X 1 3/4" Hex Bolt
1	FTLOCK	Thread Lock

	FT30285 HARDWARE KIT	LOCATION
2	5/16"-18 x 1 1/4" Bolt	Brake Line Bracket
2	5/16"-18 Nyloc Nut	
4	5/16" SAE Flat Washer	
2	5/16"-18 x 1" Thrd Frmng Bolt	
2	5/16"-18 x 1 1/4" Bolt	Bump Stop Center
2	5/16" SAE Flat Washer	
2	5/16" Split Washer	
4	7/16"-14 x 1 1/2" Bolt	Bump Stop Bracket
4	7/16"-14 Nyloc Nut	
8	7/16" SAE Flat Washer	
4	7/16"-14 x 1 1/4" bolt	Sway Bar Drop Bracket
4	7/16"-14 C-Lock Nut	
8	7/16" SAE Flat Washer	
8	3/4"-10 x 1 1/2" Bolts	Drop Brackets
8	3/4"-10 C-Lock Nut	
16	3/4" SAE Flat Washer	
2	1/4"-20 x 1" Hex Cap Bolt	ABS Line & Bracket
2	1/4"-20 C-Lock Nut	@ Radius Arm
4	1/4" SAE Flat Washer	
4	5/16"-18x1" Thrd Frmng Bolt	
2	Adel Clamp	ABS Line & Bracket
1	1/8" x 2" Cotter Pin	Drag Link
1	Lock Tight	
7	8" Zip Ties	4WD & ABS Lines



- PARTS LIST -

2011 FORD F450/F550

	FTS22147	COMPONENT BOX
2	FT30467BK	RADIUS ARM DROP 2WD/4WD DRIVER/PASSENGER
1	FT30342	PITMAN ARM
1	FT30464	HARDWARE SUB-ASSEMBLY
1	FT30143BK	FRONT BUMPSTOP DROP (DRIVER)
1	FT30144BK	FRONT BUMPSTOP DROP (PASSENGER)
1	FT30402	F450 STEERING STABILIZER DROP
1	FT3400-112P	SWAY BAR MOUNT (PASSENGER)
1	FT3400-112D	SWAY BAR MOUNT (DRIVER)
1	FT30373BK	TRAC BAR DROP BRACKET 6" & 8"
1	FT30273BK	TRAC BAR SUPPORT TUBE
2	FT30277	FRONT ABS LINE BRACKET
1	FT30285	HARDWARE KIT
1	FT30474	HARDWARE KIT

	FT30474 - HARDWARE KIT	LOCATION
3	1/2 SAE WASHER G5 ZINC	
2	1/2-13 C-LOCK NUT ZINC	
1	1/2-13 X 1-3/4 HEX BOLT G5 ZNC	
1	1/2-13 X 2-1/2 HEX BOLT G5 ZNC	
2	WASHER 12MM FLAT Z1	
1	NUT 12-1.75 NYLOK 10.9 Z1	
1	M12-1.75 X 80MM HEX BOLT G10.9	
1	THREAD LOCKING COMPOUND 1 MIL	

	FT30464	HARDWARE SUB-ASSEMBLY
1	FT104	SLEEVE TAPERED SUPER DUTY
1	FT179	SLEEVE .625 X .509 X 1.200
1	FT30403	STABILIZER CLEVIS CLEAR ZINC
1	FT30059	REAR DIFF BRAKE LINE TAB CL ZINC
2	FT30432	BRAKE LINE BRACKET
1	FT30258	SECTOR SHAFT ARM NUT
1	FT30409	8" BRAKE HARD LINE
1	FT30410	BRAKE LINE HARD UNION
1	FT30276	FRONT BRAKE LINE DROP
1	FT30348	FRONT BRAKE LINE DROP
1	FTREGCARD	REGISTRATION CARD
1	FTAS12	STICKER
2	FT22123i	INSTRUCTIONS

	FT30285 - HARDWARE KIT	LOCATION
2	5/16"-18 x 1 1/4" Bolt	Brake Line Bracket
2	5/16"-18 Nyloc Nut	
4	5/16" SAE Flat Washer	
2	5/16"-18 x 1" Thrd Fmng Bolt	
2	5/16"-18 x 1 1/4" Bolt	Bump Stop Center
2	5/16" SAE Flat Washer	
2	5/16" Split Washer	
4	7/16"-14 x 1 1/2" Bolt	Bump Stop Bracket
4	7/16"-14 Nyloc Nut	
8	7/16" SAE Flat Washer	
4	7/16"-14 x 1 1/4" bolt	Sway Bar Drop Bracket
4	7/16"-14 C-Lock Nut	
8	7/16" SAE Flat Washer	
8	3/4"-10 x 1 1/2" Bolts	Drop Brackets
8	3/4"-10 C-Lock Nut	
16	3/4" SAE Flat Washer	
2	1/4"-20 x 1" Hex Cap Bolt	ABS Line & Bracket
2	1/4"-20 C-Lock Nut	@ Radius Arm
4	1/4" SAE Flat Washer	
4	5/16"-18x1" Thrd Fmng Bolt	
2	Adel Clamp	ABS Line & Bracket
1	1/8" x 2" Cotter Pin	Drag Link
1	Lock Tight	
7	8" Zip Ties	4WD & ABS Lines

- TOOL LIST -

Required Tools (Not Included)

Floor Jack
 Jack Stands
 Assorted Metric and S.A.E sockets, and Allen wrenches
 Drill with Assorted Drill Bits



- PRE-INSTALLATION NOTES -

Read this before you begin installation-

Check all parts to the parts list above before beginning installation. If any parts are missing contact Fabtech at 909-597-7800 and a replacement part will be sent to you immediately.

Read all instructions thoroughly from start to finish before beginning the installation. If these instructions are not properly followed severe frame, driveline and / or suspension damage may occur.

Check your local city and state laws prior to the installation of this system for legality. Do not install if not legal in your area.

Prior to the installation of this suspension system perform a front end alignment and record. Do not install this system if the vehicle alignment is not within factory specifications. Check for frame and suspension damage prior to installation.

The installation of this suspension system should be performed by two professional mechanics.

Use the provided thread locking compound on all hardware.

Do not combine this suspension system with any other lift device or parts.

This suspension must be installed with Fabtech shock absorbers.

WARNING- Installation of this system will alter the center of gravity of the vehicle and may increase roll over as compared to stock.

Fabtech suspension systems when used on "Gas engine" trucks may require that the front drive shaft be modified. This is done to give adequate clearance between the driveshaft and the factory exhaust. Fabtech does not recommend modifying the exhaust and / or the catalytic converters. Contact Fabtech for additional information.

Recommend Tires and Wheels:

F450: Use 285/75R18 tires w/ OEM dually wheels

F550: Use 285/75R19.5 tires w/ OEM dually wheels

FOOTNOTE:

- May not sit level after lift, due to factory options.

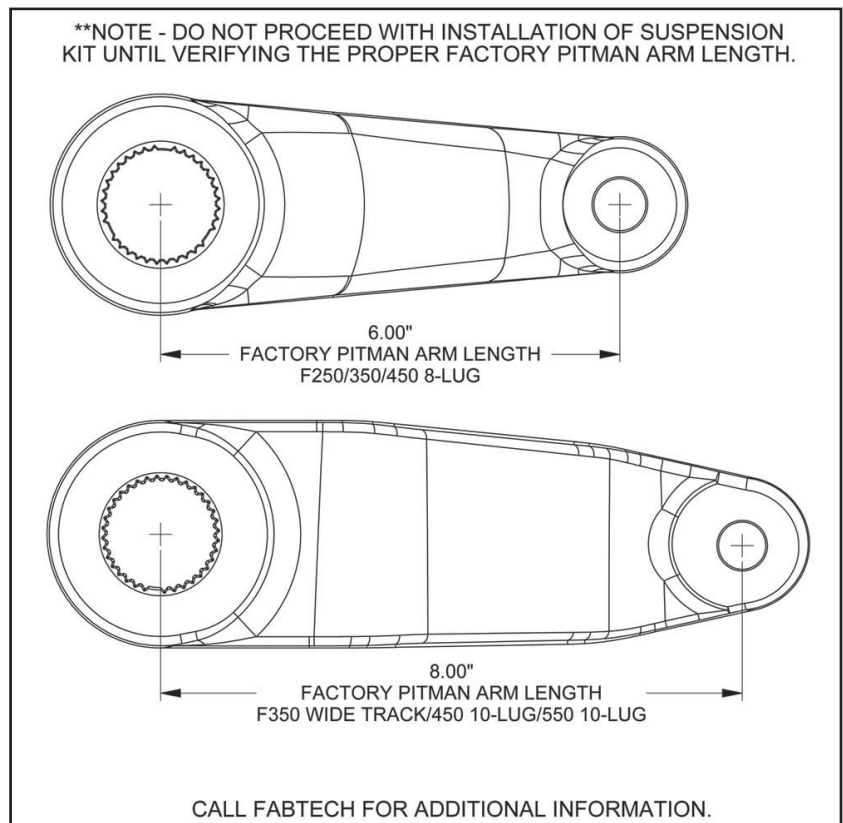

- INSTRUCTIONS -

FRONT SUSPENSION

1. Disconnect the negative terminal on the battery. Jack up the front end of the truck and support the frame rails with jack stands. **NEVER WORK UNDER AN UNSUPPORTED VEHICLE!** Remove the front tires.
2. Working from both sides of the truck, remove the brake calipers and tie them up out of the way. **DO NOT ALLOW THE CALIPERS TO HANG FROM THE BRAKE LINES!** Remove the brake line and ABS lines from the front side and the rear side of the lower spring perch on the axle and save the hardware.
3. Locate the ABS lines on the radius arms and disconnect it at the plug on the fender well. Remove the ABS line brackets from the radius arms and save the hardware.
4. Supporting the front axle with two floor jacks, remove the front shocks and discard. Remove the sway bar end links from the axle mount and save with the hardware.
5. Lower the front axle allowing the coil springs to come free of tension. **EXERCISE EXTREME CAUTION WHEN WORKING WITH COIL SPRINGS UNDER LOAD!** Remove the coil springs from the truck and discard, save the factory upper coil isolator.
6. Remove the factory steering stabilizer from the frame mount and the drag link, save the hardware. Remove the steering stabilizer frame bracket and save the hardware. Discard the frame bracket. **SEE FIGURE 1**

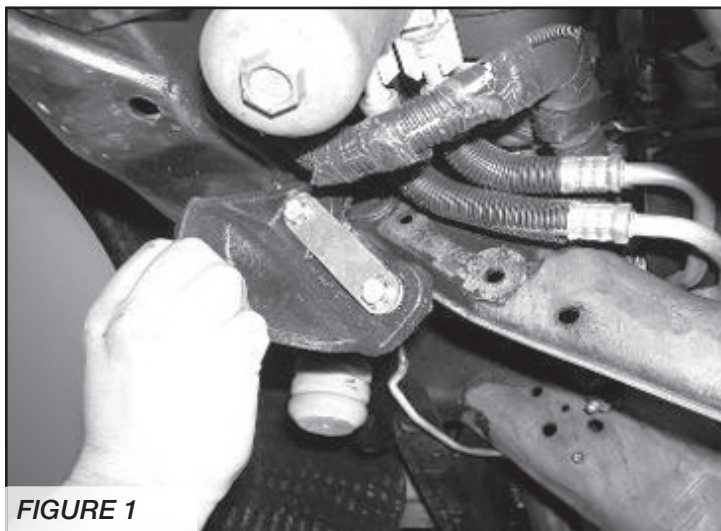

FIGURE 1

7. Remove the drag link from the pitman arm and save factory hardware (note the mounting position of the drag link to the pitman arm). You will need to use a two jaw puller to remove drag link from the pitman arm. **USE CARE NOT TO DAMAGE THE THREADS ON THE DRAG LINK!**

8. Remove the trac bar from the frame bracket and save the original hardware. Remove the trac bar bracket from the frame and save the original hardware and discard the factory trac bar bracket. **SEE FIGURE 2**

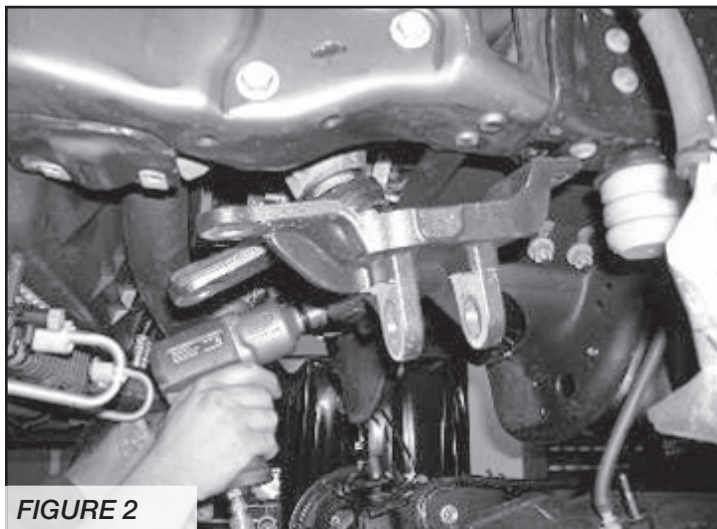

FIGURE 2

9. Remove the factory pitman arm from the steering box using a large pitman arm puller or large two-jaw puller. Discard the hardware and the pitman arm. **SEE FIGURE 3**

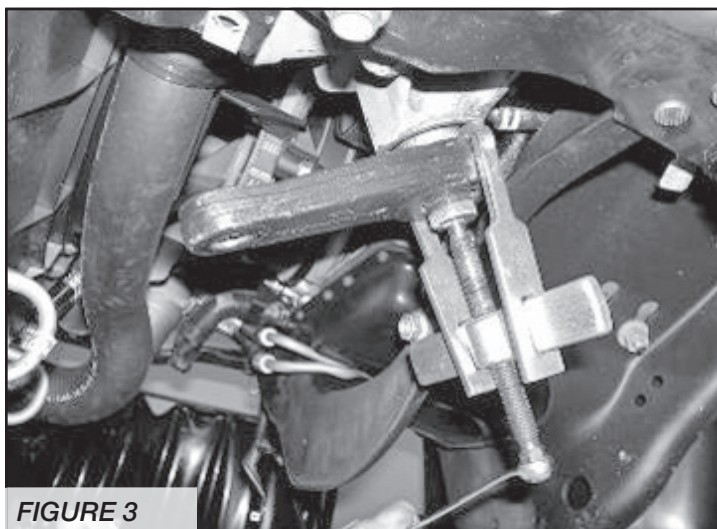
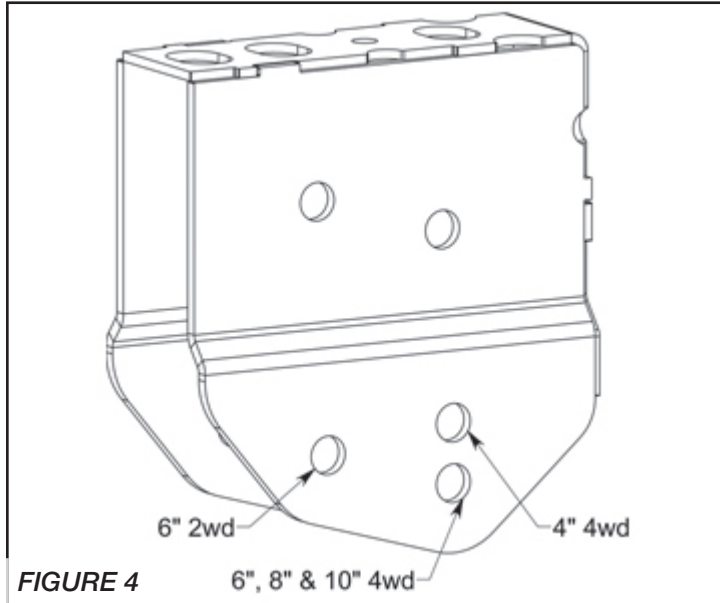

FIGURE 3

10. Locate FT30342 new drop pitman arm. Attach to the steering box in the same indexed position as the factory pitman arm was when removed. Install the provided FT30258 Sector Shaft Nut and torque to **350 ft. lbs. (Note: this is a one-time only use nut, once it is tightened on the sector shaft and removed, it must be discarded.)
11. Locate FT30373 Trac Bar Frame Bracket. Attach to the frame using the original hardware in the same position. Torque bolts to **110 ft. lbs. **DO NOT ATTACH THE TRAC BAR TO THE FRAME BRACKET AT THIS TIME.**
12. With the front axle still supported by the floor jack, remove both of the front factory radius arms from the axle and the factory frame mounts. Save the factory hardware.

13. Working from the driver side of the truck, locate FT30467 radius arm drop bracket. Place the bracket into the factory radius arm bracket on the frame. Attach the bracket to the factory bracket using the supplied 3/4" x 1 1/2" bolts, nuts, and washers through the original holes in the frame. Torque bolts to 100 ft. lbs.

14. Reinstall the radius arm onto the truck using the original hardware. Attach to the axle first then to the new drop bracket using the rear most hole. Leave loose at this time. **SEE FIGURE 4**



15. Repeat step 13-14 on the passenger side of the truck.

16. Working from both sides of the truck, locate and remove the factory front bump stops and save. These can be removed by pulling on the bump stop itself free from the cup. Remove the factory mounting cup from the frame and discard the hardware. Locate FT30143 Drv. Side front bump stop drop brackets. Using a drill with a 7/16" drill bit, drill out the factory locator pin hole in the frame. Now attach the bump stop to the hole in the frame using the supplied 7/16" x 1 1/2" bolt, nut, and washer. Once attached and aligned with the frame drill the second hole with the 7/16" drill bit. Locate FT30144 Pass. side and center on the bottom of the frame between the factory rivets. (Pass. side does not have a locating hole). Mark the two holes from the new bracket to the frame and drill the two holes. Attach the bracket to the frame with the supplied 7/16" hardware.

17. Locate the factory bumpstop cup and use a die grinder with a cut-off wheel to cut off the locating tab from the bottom. Attach the last hole with the supplied 7/16" x 1 1/2" hardware. Attach the factory bump stop cup to the new bracket using the supplied 5/16" x 1 1/4" bolt, flat washer, and split washer. Before tightening the bolt, align the flat part of the bumpstop cup to the flat side of the drop bracket. Press the factory bump stop back into the cup. **SEE FIGURES 5-6**

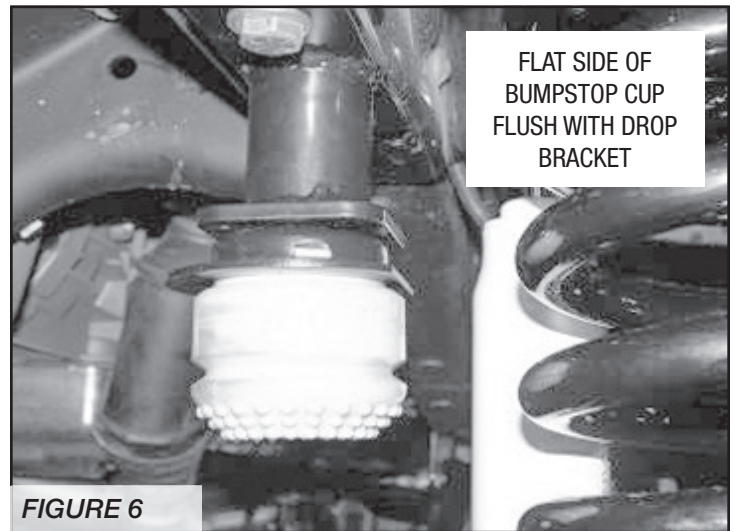
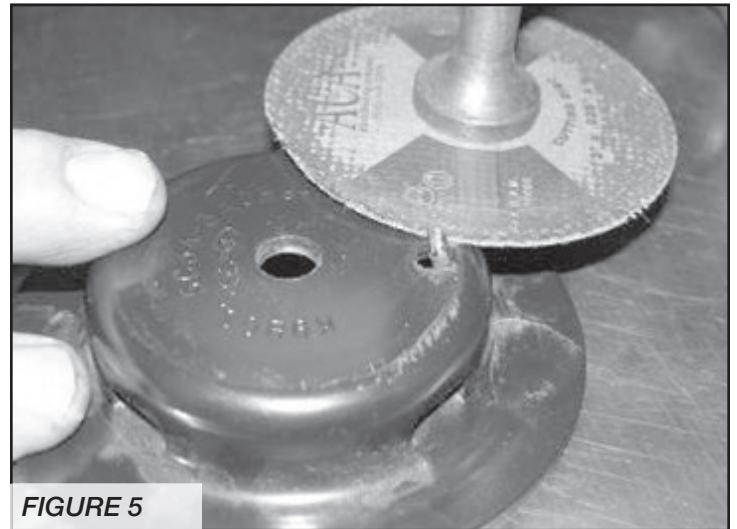

18. Using the coil springs from the 6" lift coil spring kit, install the coil springs into the truck in the factory location using the original factory upper coil isolator.

19. Using a floor jack raise the front axle enough to compress the front coils approx. 1". Locate the front shocks FTS7188 and install onto the truck. Note: Some shock mounts will require cutting a 1/4" from the top of the factory shock tab. If required, use a die grinder with a cut-off wheel and remove the top 1/4" of the tab. Sand and paint bare/ exposed metal. **SEE FIGURES 7-8**

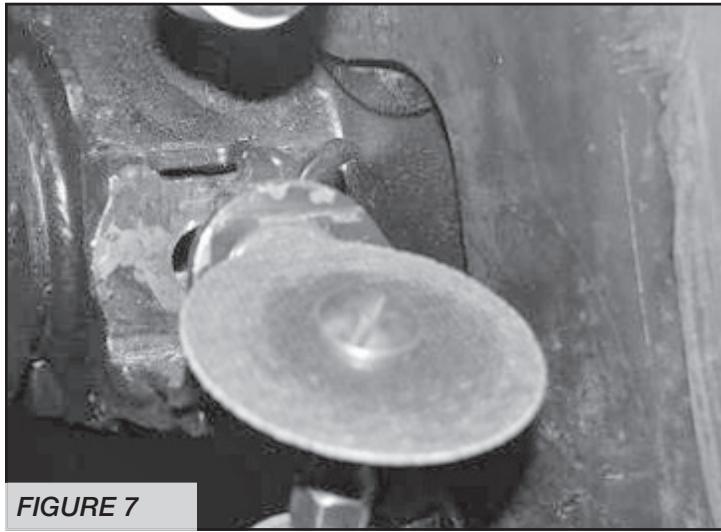

FIGURE 7

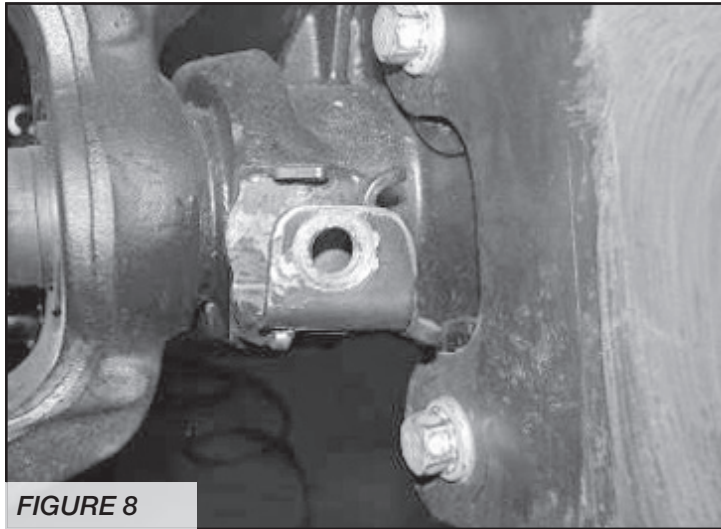

FIGURE 8

20. Torque the rear radius arm pivot bolts to **200 ft. lbs. the front pivots bolts to **200 ft. lbs.

21. Locate the factory brake line mount on the front side of the frame. Remove the bracket from the frame and save the hardware. Locate FT30276 Passenger Front Brake Line Drop Bracket and attach to the frame using the original hardware in the factory brake line hole. Locate the supplied 5/16" thread forming bolt. Use a drill with a 17/64" drill bit and drill the new hole from the drop bracket into the frame. Install the 5/16" thread-forming bolt into the new hole. Locate FT30409 Hard Brake Line Extension and separate the factory hose from the hard line. Install the supplied FT30410 union and hard line to the factory hard line. Connect the factory hose to the new hard line. Using the supplied 5/16" hardware, attach the factory brake line to the new drop bracket. You will need to carefully bend the hard line down to meet the new brake line bracket. **USE CARE NOT TO DAMAGE THE HARD LINE.**

22. Repeat step #21 on the Driver side of vehicle Using FT30348 Driver Front Brake Line Drop Bracket.

SEE FIGURES 9-12

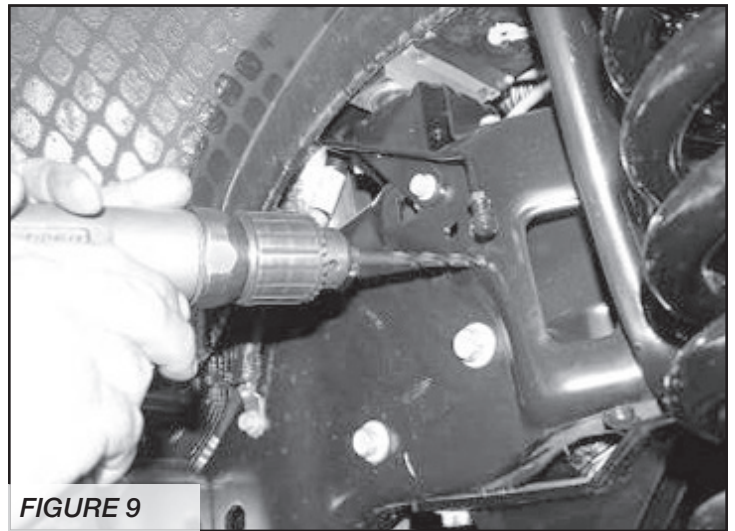

FIGURE 9

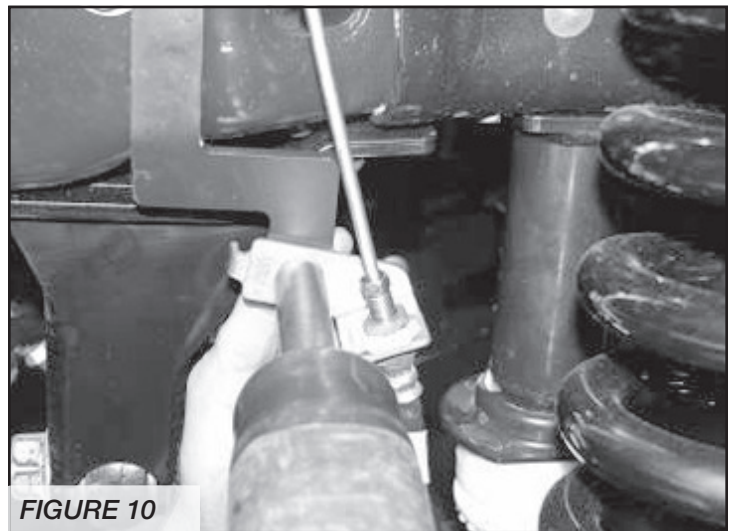
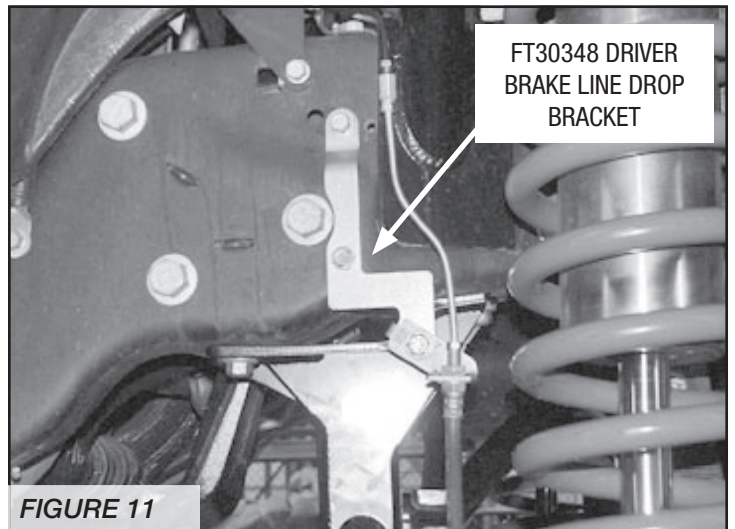

FIGURE 10



FT30348 DRIVER
BRAKE LINE DROP
BRACKET

FIGURE 11

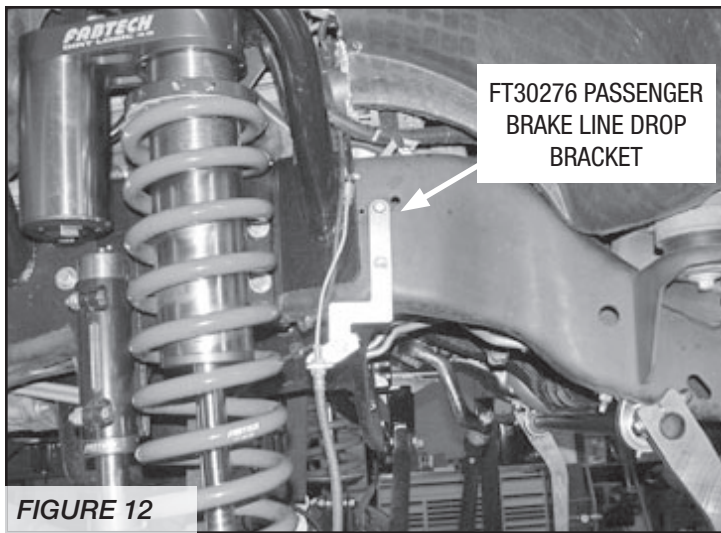

FIGURE 12

23. Working on the driver side, disconnect the four wheel drive vacuum line from the front brake line bracket and reposition and reconnect behind the coil spring mount. Follow the 4wd vacuum line up to the 120 degree connector and remove it from the line and re-connect the lines with the existing line splint. Attach the vacuum line to the ABS line at the coil mount with 2 of the supplied zip ties and attach the vacuum line to the front differential vent hose with 2 more zip ties. (this keeps all the lines in place during suspension travel, failure to follow this step could cause ABS or 4wd failure). **SEE FIGURES 13-16**

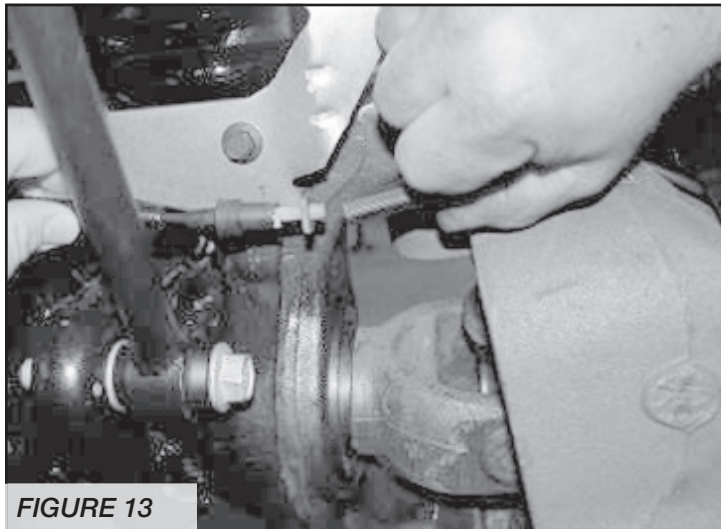

FIGURE 13

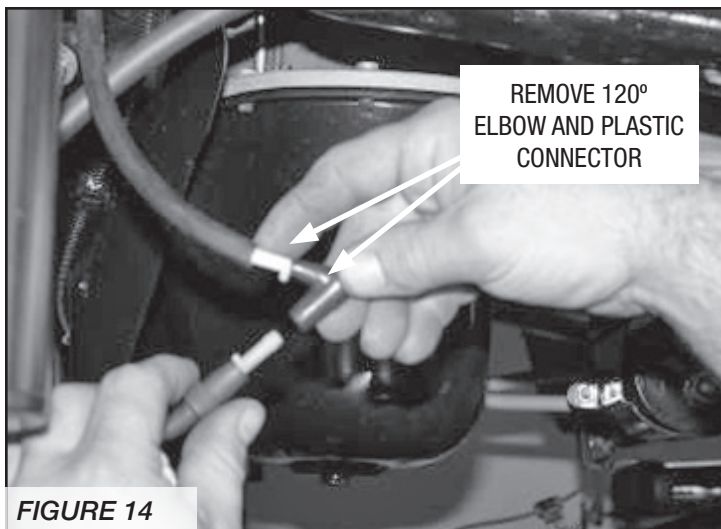

FIGURE 14

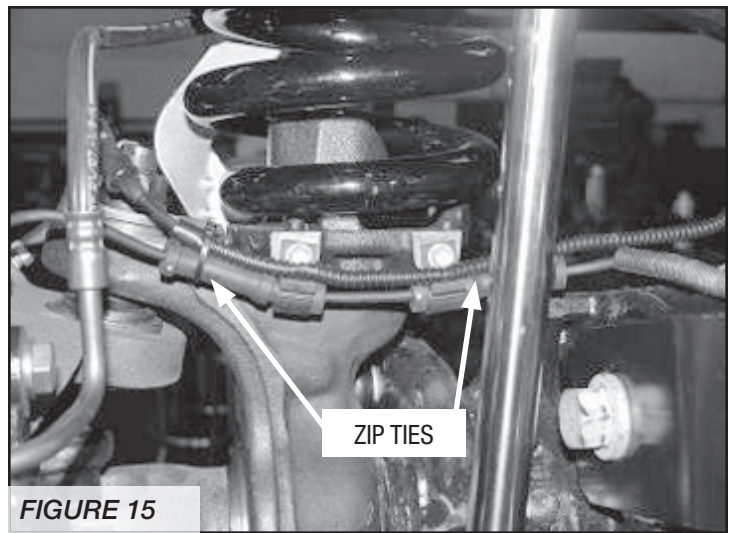

FIGURE 15

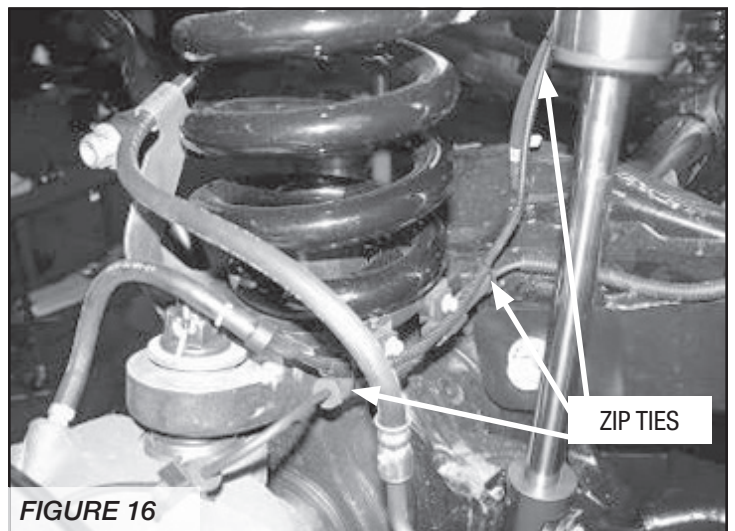

FIGURE 16

24. Locate FT30277 ABS Line Bracket and the supplied 1/4" hardware, Adel clamp, and thread-forming bolts. Locate the two slotted holes on the radius arm, measure a 1/2" in front of the upper hole and 3/4" from the top of the radius arm. Mark and drill a 7/32" pilot hole. Using a thread-forming bolt, attach the line bracket to the radius arm in the middle hole. Now mark and drill the bottom hole in the line bracket to the radius arm. Remove the ABS socket connector from the frame and re-connect the ABS line. Install the factory front ABS mount onto the front of the radius arm. Place the provided Adel clamp onto the ABS line mount (this may need to be moved) and attach to the new bracket with the supplied 1/4" hardware.

SEE FIGURES 17-20

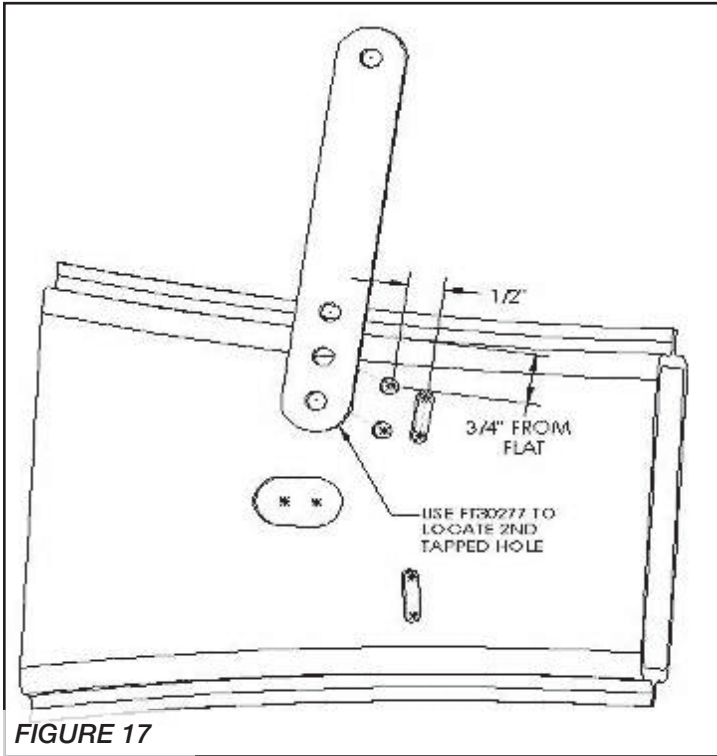

FIGURE 17

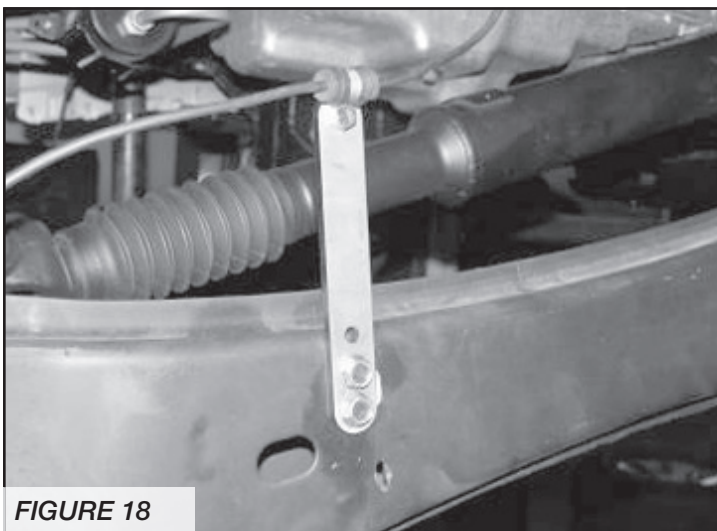

FIGURE 18

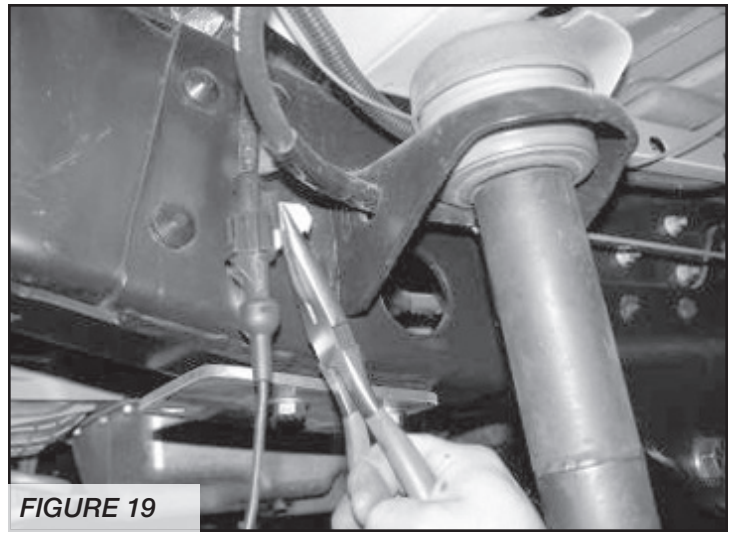

FIGURE 19

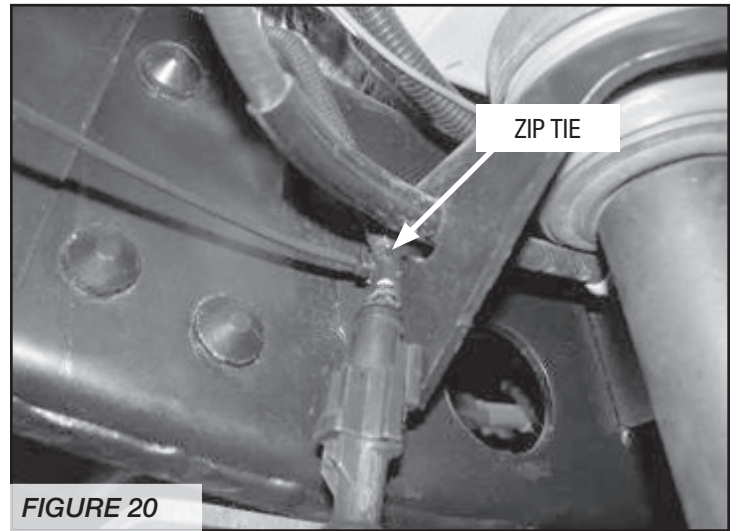

FIGURE 20

25. Remove the front sway bar from the frame mounts and save the hardware. Locate FT3400-110D & P sway bar frame drop brackets and attach to the frame (AS SHOWN IN PHOTOS) where the sway bar was originally attached using the factory hardware. **MOUNT THE DRIVER SIDE BRACKET ON THE PASSENGER SIDE, AND THE PASSENGER SIDE ON THE DRIVER SIDE.** Using the supplied 7/16" X 1 1/4" hardware, attach the sway bar to the new drop brackets. Reattach the factory sway bar end links to the axle mounts using the original hardware (Torque to **40 ft. lbs. once the truck is on the ground; do not tighten while the suspension is in the air). The new drop brackets are slotted at both mounting points. For the 6" lift, position the frame mount and sway bar all the way forward toward the front of the truck and torque to **35 ft. lbs. **SEE FIGURES 21-22**

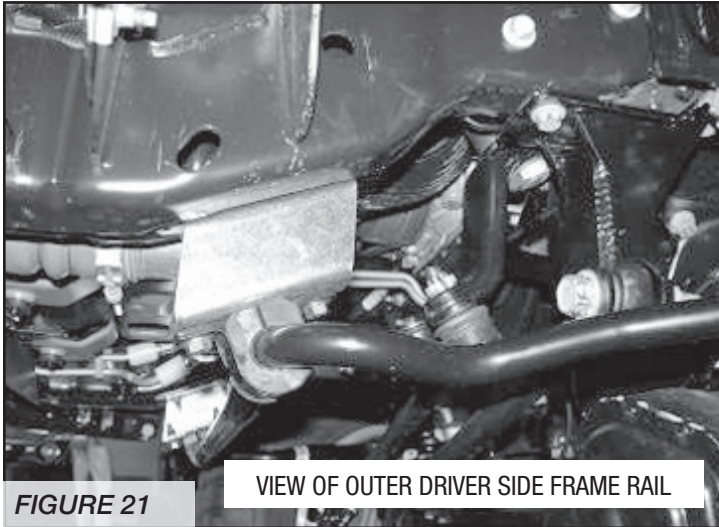

FIGURE 21

VIEW OF OUTER DRIVER SIDE FRAME RAIL

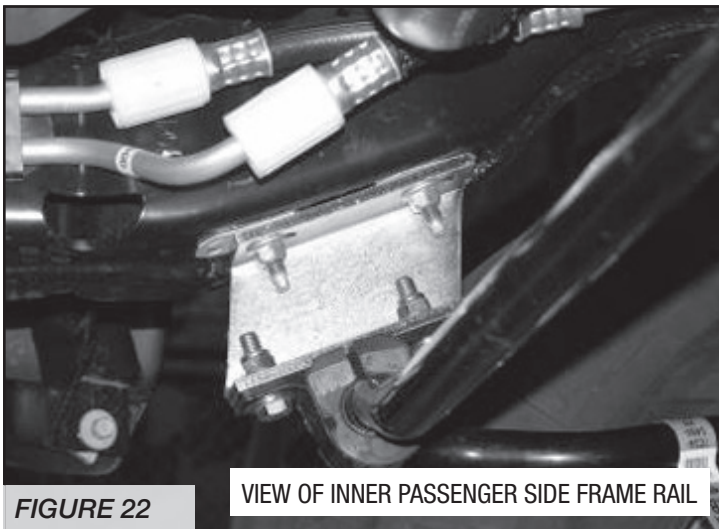

FIGURE 22

VIEW OF INNER PASSENGER SIDE FRAME RAIL

26. Position the factory trac bar into the new trac bar bracket. Note: You may need to raise the axle up or down to align the hole. Using the original bolt insert it from the front side of the bracket towards the back. Do not push the bolt fully through at this time.

27. Locate FT30273 trac bar support bracket and attach first to the forward motor mount bolt on the driver side of the truck, then line the other end up to the trac bar bolt. Torque the factory motor mount bolt to **75 ft. lbs and the trac bar bolt to **400 ft. lbs. Attach the drag link to the bottom of the new pitman arm (opposite of the factory mounting position on the factory pitman arm) with the factory hardware. Torque the nut to ** 148ft. lbs.

SEE FIGURE 23

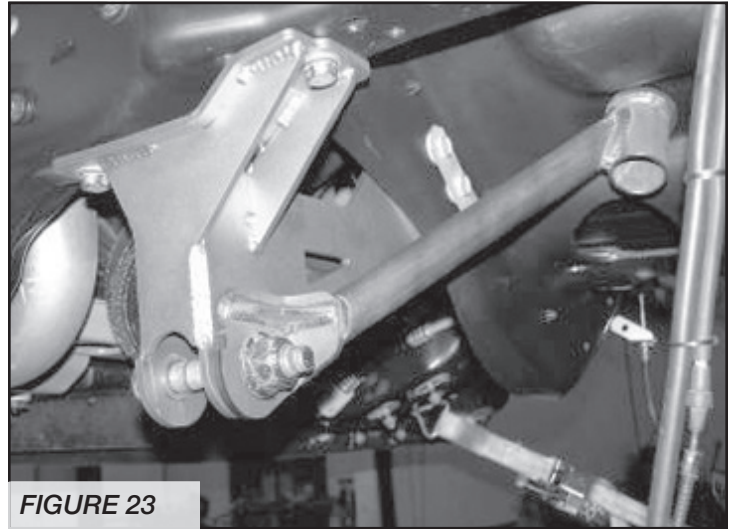

FIGURE 23

28. Locate the factory steering stabilizer. Use a die grinder with a sanding disc and remove the staked washer from the back of the stabilizer mounting pin. Locate FT179 Sleeve, FT30403 Clevis, FT104 Tapered Sleeve, and the supplied 1/2" Hardware. With the factory mounting pin removed from the stabilizer, insert the new sleeve into the stabilizer and attach it to the drag link. Torque the 1/2" bolts to ** 90 ft. lbs. **SEE FIGURE 24**

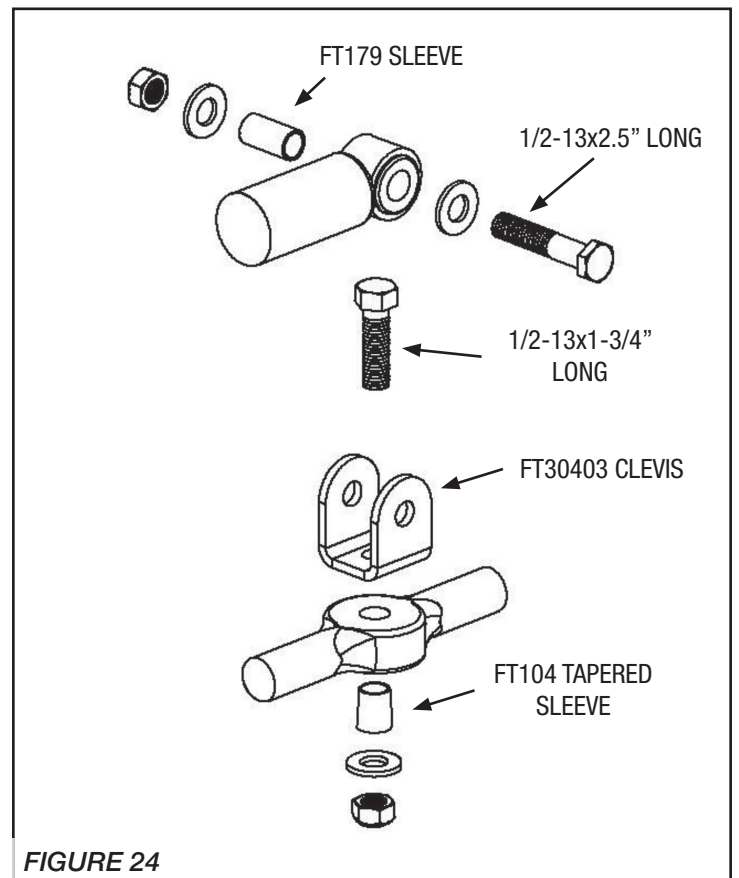

FIGURE 24

29. Locate FT30402 steering stabilizer drop bracket and install in the factory location using the original hardware. Torque to **50 ft. lbs. Reattach the factory stabilizer to the frame bracket using the 80mm long, 12mm diameter bolt, washers and nut. If installing a Fabtech stabilizer do so at this time. **SEE FIGURES 25-26**

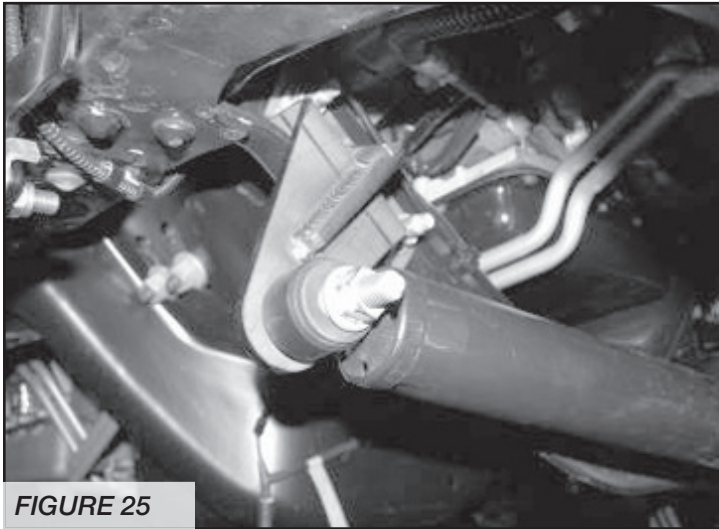

FIGURE 25

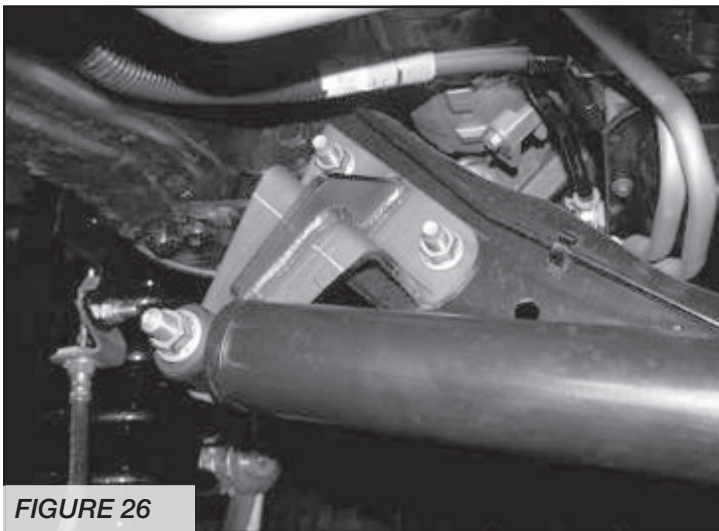

FIGURE 26

30. Refer to owner's manual for proper brake bleeding procedure.
31. Install tires and wheels and torque lug nuts to wheel manufacturer's specifications. Turn front tires left to right and check for appropriate tire clearance. **Note - Some oversized tires may require trimming of the front bumper & valance.**
32. Check front end alignment and set to factory specifications. Readjust headlights.
33. Recheck all bolts for proper torque.
34. Recheck brake hoses, ABS wires and suspension parts for proper tire clearance while turning tires fully left to right.
35. Check the fluid in the front and rear differential and fill if needed with factory specification differential oil. **Note - some differentials may expel fluid after filling and driving. This can be normal in resetting the fluid level with the new position of the differential/s.**

36. Install Driver Warning Decal. Complete product registration card and mail to Fabtech in order to receive future safety and technical bulletins on this suspension

Vehicles that will receive oversized tires should check ball joints and all steering components every 2500-5000 miles for wear and replace as required.

RETORQUE ALL NUTS, BOLTS AND LUGS AFTER 50 MILES AND PERIODICALLY THEREAFTER.

S.A.E. Bolt Torque Specification Chart



Grade 5



Grade 8



Metric

STANDARD				METRIC		
	Grade 5	Grade 8			Grade 8.8	Grade 10.9
SIZE	ft. lbs.	ft. lbs.		SIZE	ft. lbs.	ft. lbs.
1/4"	10	14		M-6	7	12
5/16"	21	29		M-8	17	29
3/8"	37	52		M-10	35	58
7/16"	59	83		M-12	65	100
1/2"	90	127		M-14	100	160
9/16"	129	184		M-16	150	240
5/8"	179	254		M-18	200	300
3/4"	317	450		M-20	300	400