



2005 - 2007 FORD F-250/350 SUPER DUTY

4WD FTS22029 6" BASIC KIT



2005-07 FORD SUPER DUTY 6" BASIC SYSTEM



**2005 - 2007 FORD F-250/350 SUPER DUTY 4 WD
FTS22029BK 6" BASIC KIT**

PARTS LIST:

Qty	Part #	Description
2	FT30467BK	Radius Arm Drop Dr. / Pass 2wd & 4wd
2	FT30169BK	Sway Bar Frame Drop Bracket
1	FT30122	Pitman Arm
1	FT30143BK	Frnt. Bump stop Drop Driver
1	FT30144BK	Frnt. Bump stop Drop Passenger
1	FT30175BK	Trac Bar Drop Bracket
1	FT30178BK	Trac Bar Support tube
1	FT30133	Steering Stab. Drop Bracket
2	FT30154	Frnt. Brake Line Bracket
1	FT30176	Hardware Bag
2	FT22029i	Instruction Sheet
1	FT30258	Sector Shaft Nut

TOOL LIST:

- **FLOOR JACK**
- **JACK STANDS**
- **ASSORTED METRIC AND S. A. E. WRENCHES AND SOCKETS**
- **DRILL WITH ASSORTED DRILL BITS**

CHECK ALL PARTS INCLUDED IN THIS KIT TO THE PARTS LIST ABOVE BEFORE BEGINNING INSTALLATION OF THE KIT.

READ ALL INSTRUCTIONS THOROUGHLY FROM START TO FINISH BEFORE BEGINNING INSTALLATION.

LIFT INSTRUCTIONS:

1. Disconnect the negative terminal on the battery. Jack up the front end of the truck and support the frame, at the front frame rails, with jack stands. **NEVER WORK UNDER AN UNSUPPORTED VEHICLE.** Remove the front tires.
2. Working from both sides of the truck, remove the brake calipers and tie them up out of the way. **DO NOT ALLOW THE CALIPERS TO HANG FROM THE BRAKE LINES!** Remove the brake line and ABS lines from the front side and the rear side of the lower spring perch on the axle and save the hardware.
3. Supporting the front axle with two floor jacks, remove the front shocks and discard. Remove the sway bar end links from the axle mount and save the hardware.
4. Lower the front axle allowing the coil springs to come free of tension. **EXERCISE EXTREME CAUTION WHEN WORKING WITH COIL SPRINGS UNDER LOAD!** Remove the coil springs from the truck and discard, save the factory upper coil isolator.
5. Remove the factory steering stabilizer from the frame mount and save the hardware. Remove the steering stabilizer frame bracket and save the hardware. Discard the frame bracket. Leave the steering stabilizer connected to the drag link. SEE PHOTO BELOW.



6. Remove the drag link from the pitman arm and save factory hardware. You will need to strike the pitman arm with a large hammer to dislodge the drag link for the pitman arm. **USE CARE NOT TO KIT THE THREADS ON THE DRAG LINK!**
7. Remove the trac bar from the frame bracket and save the original hardware. Remove the trac bar bracket from the frame and save the original hardware and discard the factory trac bar bracket. SEE PHOTO IN NEXT COLUMN.

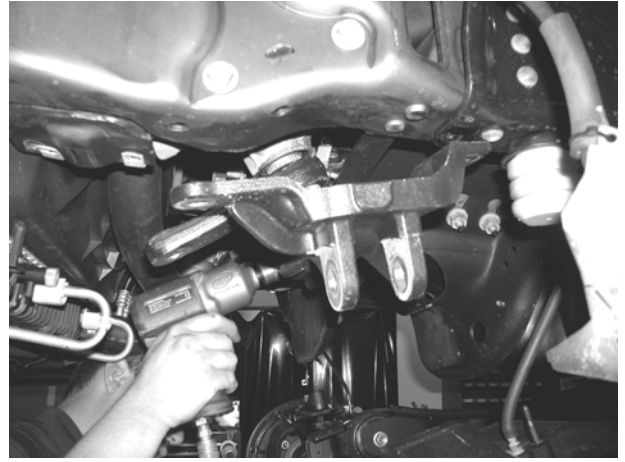

8. Remove the factory pitman arm from the steering box using a large pitman arm puller or large two-jaw puller. Save the hardware and discard the pitman arm. SEE PHOTO BELOW.



9. Locate FTS30122 new drop pitman arm. Attach to the steering box in the same indexed position as the factory pitman arm was when removed. **Install the provided FT30258 Sector Shaft Nut and torque to 350 ft. lbs. (Note: this is a one-time only use nut, once it is tightened on the sector shaft and removed, it must be discarded.**
10. Locate FT30175 trac bar frame bracket. Attach to the frame using the original hardware in the same position. Torque bolts to 110 ft. lbs. **DO NOT ATTACH THE TRAC BAR TO THE FRAME BRACKET AT THIS TIME.**
11. Locate the ABS lines on the radius arms and disconnect it at the plug on the fender well. Remove the ABS line brackets from the radius arms and save the hardware.
12. With the front axle still supported by the floor jack, remove both of the front factory radius arms from the axle and the factory frame mounts. Save the factory hardware.

13. Working from the driver side of the truck, locate FT30467 radius arm drop bracket. Place the bracket into the factory radius arm bracket on the frame. Attach the bracket to the factory bracket using the supplied $\frac{3}{4}$ " x $1\frac{1}{2}$ " bolts, nuts, and washers through the original holes in the frame. Torque bolts to 100 ft. lbs.
14. Using a drill with a $\frac{7}{16}$ " drill bit, drill the two remaining holes out. The hole on the inside of the bracket will need to be drilled through the frame only and the hole on the rear of the bracket will need to be drilled through the Fabtech bracket. Attach using the supplied $\frac{7}{16}$ " x $1\frac{1}{2}$ " bolts, nuts, and hardware. SEE PHOTOS BELOW.

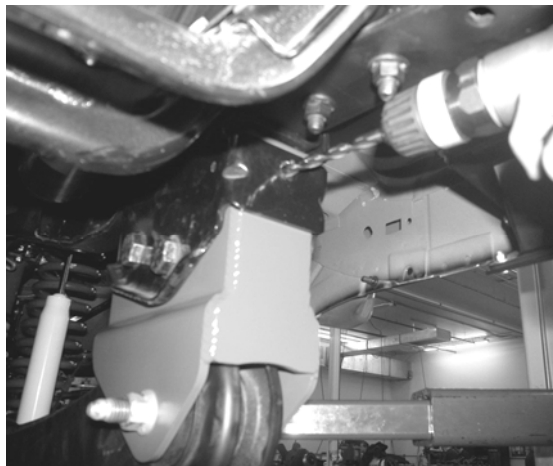
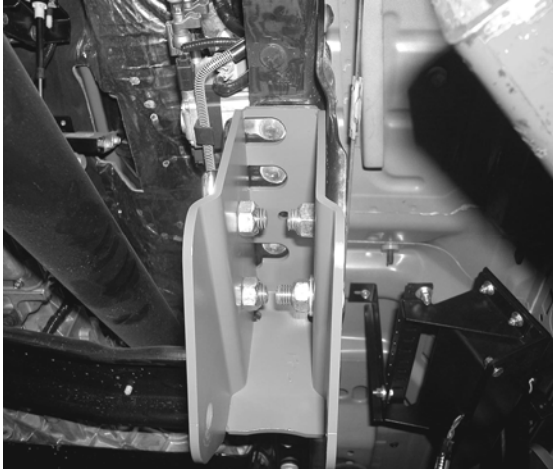

15. Reinstall the radius arm onto the truck using the original hardware. Attach to the axle first then to the new drop bracket using the rearward hole. Leave loose at this time. SEE DRAWING IN NEXT COLUMN.

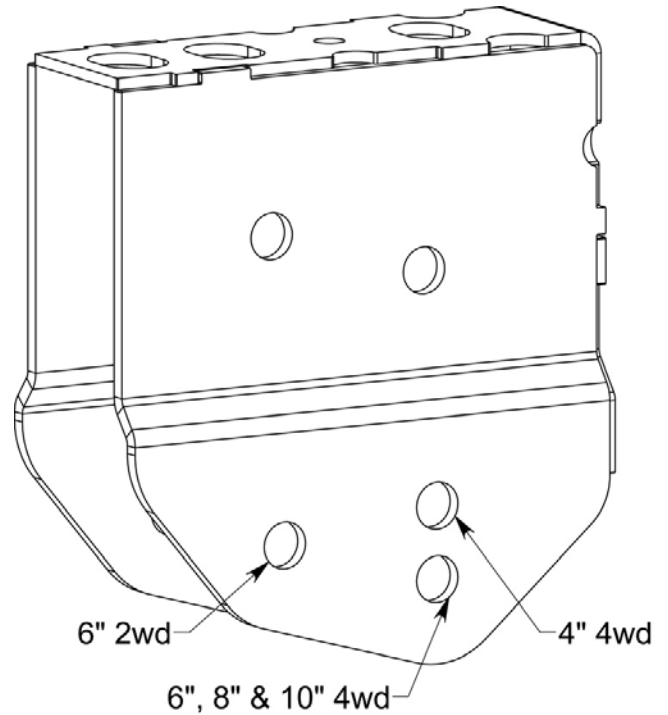

16. Repeat step thirteen thru fifteen on the passenger side of the truck.
17. Working from both sides of the truck, locate and remove the factory front bump stops and save. These can be removed by pulling on the bump stop itself, free from the cup. Remove the factory mounting cup from the frame and discard the hardware. Locate FT30143 and FT30144 front bump stop drop brackets. Using a drill with a $\frac{15}{32}$ " drill bit, drill out the factory locator pin hole in the frame. Now attach the bump stop to the hole in the frame using the supplied $\frac{7}{16}$ " x $1\frac{1}{2}$ " bolt, nut, and washer. Once attached and aligned with the frame, drill the second hole with the $\frac{15}{32}$ " drill bit. Attach the last hole with the supplied $\frac{7}{16}$ " x $1\frac{1}{2}$ " hardware. Attach the factory bump stop cup to the new bracket using the supplied $\frac{5}{16}$ " x $1\frac{1}{4}$ " bolt, flat washer, and split washer. Press the factory bump stop back into the cup. SEE PHOTO BELOW.



Photo shown without bump stop installed

18. Using the coil springs from the 6" lift coil spring kit, **(8" coils will not work with this bracket kit)**

install the coil springs into the truck in the factory location using the original factory upper coil isolator.

19. Using a floor jack raise the front axle enough to compress the front coils approx. 1". Locate the front shocks FTS7188 and install onto the truck.
20. Torque the rear radius arm pivot bolts to 200 ft. lbs. the front pivots bolts to 200 ft. lbs.
21. Locate the factory brake line mount on the front side of the coil bucket. Remove the bracket from the mount and save the hardware. Locate FT30154 front brake line bracket and attach to the coil bucket using the original hardware. Using the supplied 1/4" x 1" hardware, attach the brake line to the bracket. You will need to carefully bend the hard line down to meet the new brake line bracket. **USE CARE NOT TO DAMAGE THE HARD LINE. SEE PHOTO ON NEXT PAGE.**



22. Reattach the ABS line to the radius arms in the original location using the original hardware. Plug the ABS line back together at the fender well.
23. Locate FT30133 steering stabilizer drop bracket and install in the factory location using the original hardware. Torque to 50 ft. lbs. Reattach the stabilizer to the bracket. SEE PHOTO BELOW.



Picture Shown With Stabilizer Installed

24. Remove the front sway bar from the frame mounts and save the hardware. Locate FT30169 sway bar frame drop brackets and attach to the frame where the sway bar was originally attached using the factory hardware. Using the supplied 3/8" X 1 1/4" hardware attach the sway to the new drop brackets and torque to 35 ft. lbs.
25. Reattach the factory sway bar end links to the axle mounts using the original hardware. Torque to 40 ft. lbs.
26. Position the factory trac bar into the new trac bar bracket. Note: You may need to raise the axle up or down to align the hole. Using the original bolt insert it from the front side of the bracket towards the back. Do not push the bolt fully through at this time.
27. Locate FT30178 trac bar support bracket and attach first to the forward motor mount bolt on the driver side of the truck, then line the other end up to the trac bar bolt. Torque the factory motor mount bolt to 75 ft. lbs and the trac bar bolt to 400 ft. lbs. SEE PHOTO BELOW.

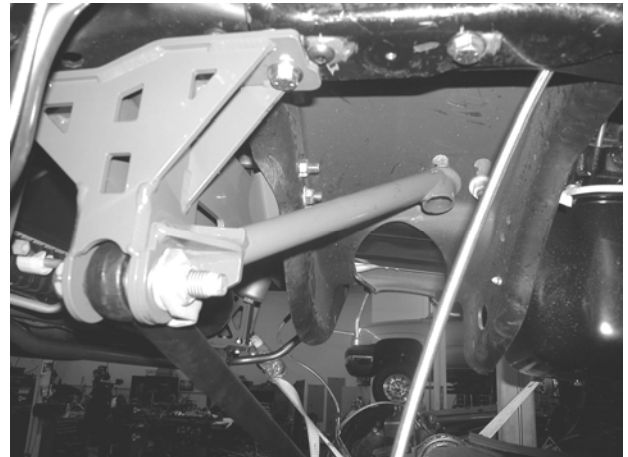

28. Install the front tires and wheels. Torque lug nuts to wheel manufacturers specifications.
29. Re-check all front hardware at this time for correct torque tightness.
30. Check the front brake lines and ABS line at this time for proper clearance from all moving part. You will want to steer the wheels from left to right to make sure the lines clear the wheels.
31. Check the front-end alignment and set to the factory specifications. Re-adjust headlights.

REAR LIFT INSTRUCTIONS ARE ENCLOSED WITH REAR LIFT BOX.

RETORQUE ALL NUTS, BOLTS AND LUGS AFTER 500 MILES.