



Installation Instructions

VICOWL

Product Number: VC4000

2019 Chevy 1500

SAFETY

Your safety and the safety of others is very important.

- In order to help you make informed decisions about safety, we have provided installation instructions and other information.
- These instructions alert you to potential hazards that could hurt you or others.
- Please do a job safety analysis (JSA) before each task to identify potential hazards for your situation and remove/protect against them.
- You must use your own good judgment and take your time.

Read and understand all safety precautions and instructions before installing this product.

THIS PRODUCT IS FOR OFFROAD USE ONLY. ALL LIABILITY FOR INSTALLATION AND USE RESTS WITH THE OWNER.

CARELESS INSTALLATION AND OPERATION CAN RESULT IN SERIOUS INJURY OR EQUIPMENT DAMAGE.

Injury hazard

Failure to observe these instructions could lead to severe injury or death.

- **Always** remove jewelry and wear eye protection.
- **Always** use extreme caution when jacking up a vehicle for work. Set emergency brake and use tire blocks. Locate and use the vehicle manufacturers designated lifting points. Use jack stands.
- **Always** use appropriate and adequate care in lifting components into place.
- **Always** insure components will remain secure during installation and operation.
- **Always** wear safety glasses when installing this kit. A drilling operation will cause flying metal chips. Flying chips can cause serious eye injury.
- **Always** use extreme caution when drilling on a vehicle. Thoroughly inspect the area to be drilled (on both sides of material) prior to drilling and relocate any objects that may be damaged.
- **Always** use extreme caution when cutting and trimming during fitting.
- **Always** tighten all nuts and bolts securely per installation instructions.
- **Always** route electrical cables carefully. Avoid moving parts, components that become hot and rough or sharp edges.
- **Always** insulate and protect all exposed wiring and electrical terminals.
- **Always** perform regular inspections and maintenance on mounts and related hardware.



Installation Instructions

VICOWL

Product Number: VC4000

2019 Chevy 1500

I. Tools Required

- 3/16” Allen Wrench
- Open end wrench
- Socket set and ratchets
- Scissors
- Drill bit – 1/4”
- Blue painters tape
- Knife
- Pick or small flat head screwdriver
- Plastic panel pry bar

We recommend two people perform the installation as items are heavy and may need to be held in place while installing.

II. Provided Material

Fab Fours Identification	Component Description	BOM Qty
50161- HW	Oil-Embedded Thrust Bearing	2
50161- HW	Oil-Embedded Flanged Sleeve Bearing	2
50161- HW	Threadlocker, Blue Loctite® 242, 0.02 oz. Capsule	1
50161- HW	3/8"-16 x 1.25", HHCS , Zinc, GR8	6
50161- HW	5/16-18, Nylock hex nut	11
50161- HW	5/16 FLAT WASHER 18/8SS	11
50161- HW	5/16-18 x 3/4", BHCS, 18-8, SS	9
50161- HW	5/16" bonded sealing washer	9
50161- HW	1/2 SAE FLAT WASHER GRADE 8 Z&Y	2
50161- HW	17/32 Drill Bit w/ 1/2 shank HSS Silver & Deming	1
50161- HW	3/8"- x , Expandable Inset Tool , ,	1
50161- HW	3/8-16 X 3/4 Button Socket Cap Screw 18/8SS	10
50161- HW	Washer, Bonded, 3/8" ID x 3/4" OD	10



Installation Instructions

VICOWL

Product Number: VC4000

2019 Chevy 1500

50161- HW	.375-16 Knurled Rivet Nut	4
50161- HW	Ball Stud, 10mm, 5/16"-18, SS	2
50161- HW	3/8"-SAE x , Flat Washer , Zinc, GR8	10
50161- HW	3/8"-SAE x , Lock Washer , Zinc, GR8	6
50161- HW	3/8-16 NYLON INSERT L/N GR.8 Z&Y	2
50161- HW	1/4"-20 x 1" , HHCS, Zinc, GR8	2
50161- HW	1/4"-20 x , Hex Nut , Zinc, GR8	2
50161- HW	1/4"-SAE x , Lock Washer , Zinc, GR8	2
50161- HW	1/4"-SAE x , Flat Washer , Zinc, GR8	4

Factory Vehicle Prep

1. Apply a small amount of blue painter's tape across the hood and fender on both driver and passenger side. Mark the tape with a straight-line perpendicular with the hood and fender body seam. Use a knife to cut the tape along the hood and fender seam.

Note: Step one is recommended to assist you in realignment of the hood during reassembly.

2. Loosen the four (4) nuts that secure the hood to the upper hood hinge bracket so they can be removed by hand. **(Figure 1, #1)**



Figure 1

3. Disconnect any electrical connections and washer fluid lines if your vehicle is equipped.
4. With assistance, remove the hood bolts and remove the hood.



Installation Instructions

VICOWL

Product Number: VC4000

2019 Chevy 1500

- Using a small pick or screwdriver, pry out on the metal spring clip (**Figure 2, #2**). Pull the air spring head (**Figure 2, #1**) away from the ball stud (**Figure 2, #4**) while the spring clip is pulled away. Disconnect the air spring from the bracket only and leave attached to frame rail. Rotate forward out of the way.

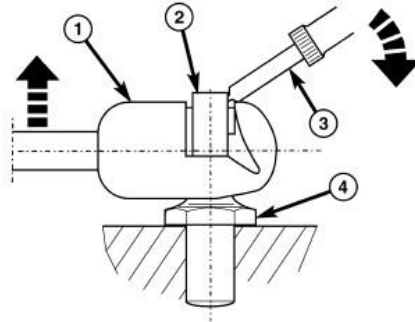

Figure 2

- Remove the two (2) lower hood hinge bolts. (**Figure 3, #1**)

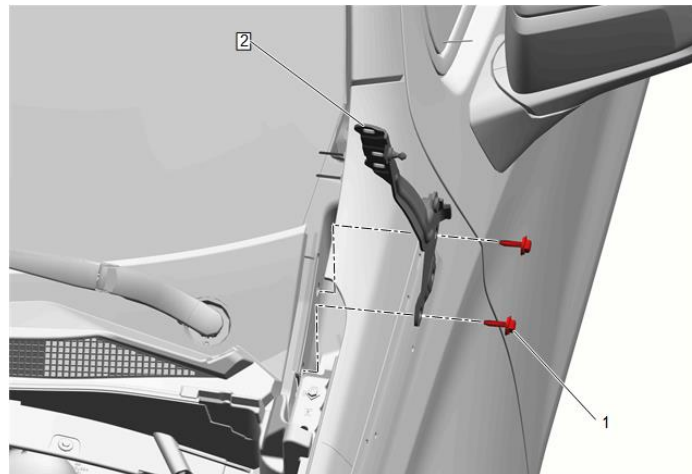

Figure 3

- Remove the hood hinges from the fender area and set aside as they won't be used with this product.
- Remove the three (3) screws holding the splash shield to the wheel well. (**Figure 4, #1**)
- Remove the single bolt from the splash shield. (**Figure 4, #2**)



Installation Instructions

VICOWL

Product Number: VC4000

2019 Chevy 1500

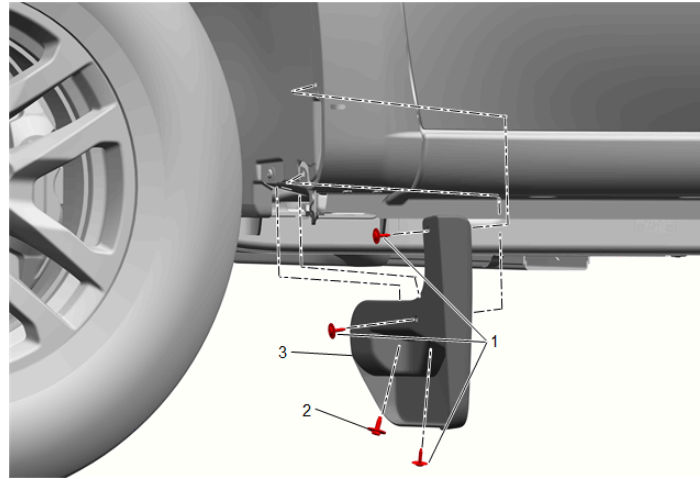

Figure 4

10. Remove the splash shield from the fender area and set aside for future reinstallation.
11. Remove the eleven (11) wheel well liner bolts. **(Figure 5, #1)**
12. Remove retainer from the wheel well liner. **(Figure 5, #2)**
13. Remove the wheel well liner on both sides of the vehicle and set aside for future reinstallation. **(Figure 5, #3)**

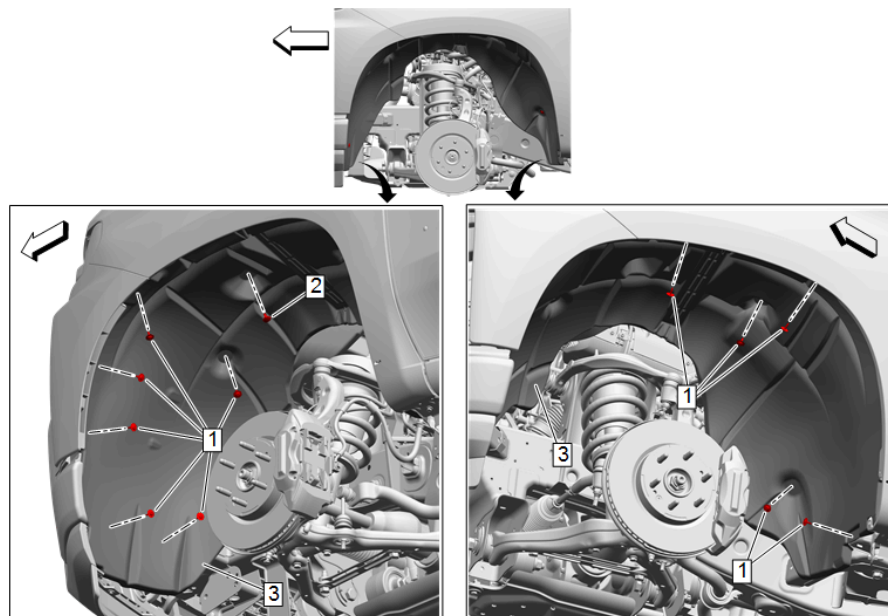

Figure 5



Installation Instructions

VICOWL

Product Number: VC4000

2019 Chevy 1500

Fab Fours Hood Hinge Installation

Note: Both driver side and passenger side brackets install the same way procedurally, but opposite as driver side and passenger side.

1. Fully assemble and tighten the driver side bracket. First, install the brass bushing into the upper hole in the upper bracket. **(Figure 6)**
2. Stack the 3/8"-16 Nylock nut on the washer and place over the brass bushing. Add the brass thrust washer, followed by the lower bracket, flat washer and 3/8"-16 bolt. Tighten the Nylock nut making sure the thrust washer does not pop out of the brass bushing. **(Figure 6)**
3. Fully assemble and tighten the passenger side opposite of what is shown in **Figure 6**.

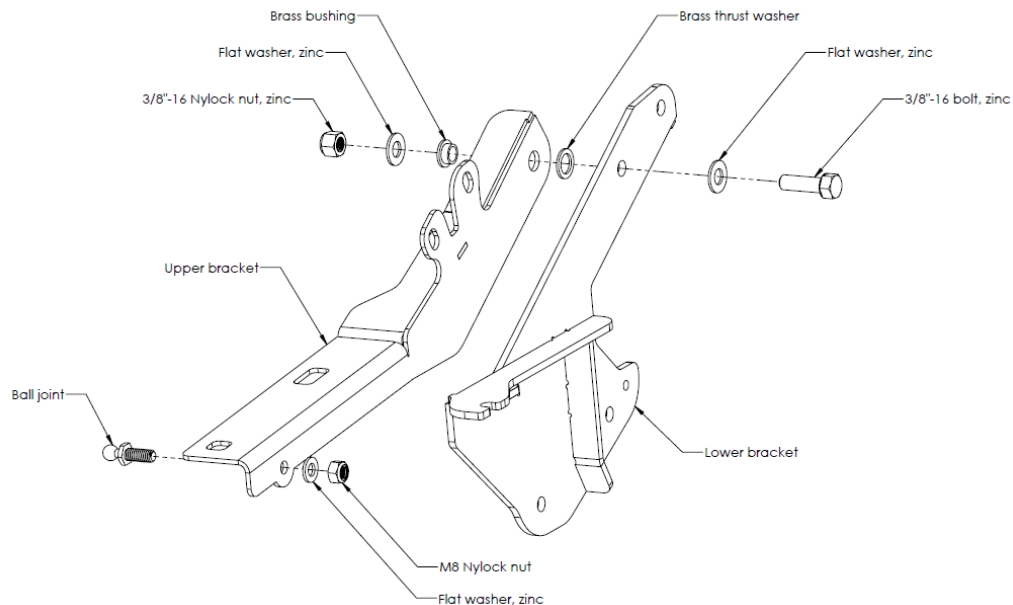

Figure 6

4. Install and fully tighten the antenna to the passenger side bracket using the provided 1/4"-20 hardware. **(Figure 7)**



Installation Instructions

VICOWL

Product Number: VC4000

2019 Chevy 1500

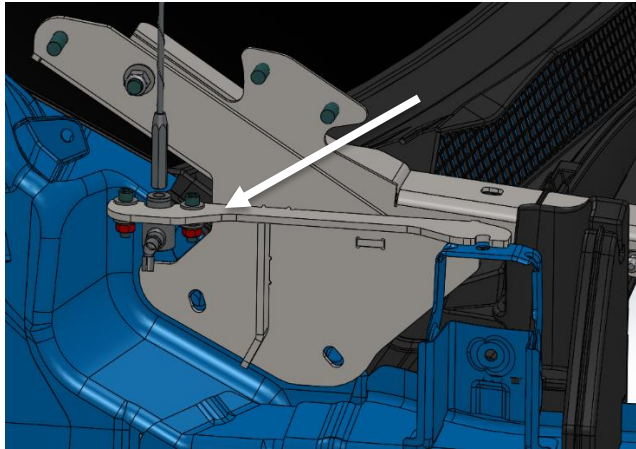

Figure 7

5. Insert the passenger side bracket where the OEM bracket was removed.
6. Using the factory fender bolt, hand tighten the front bracket mount. (**Figure 8, dashed white line**)
7. Loosely install the two (2) factory bracket bolts (**Figure 8, solid white lines**)

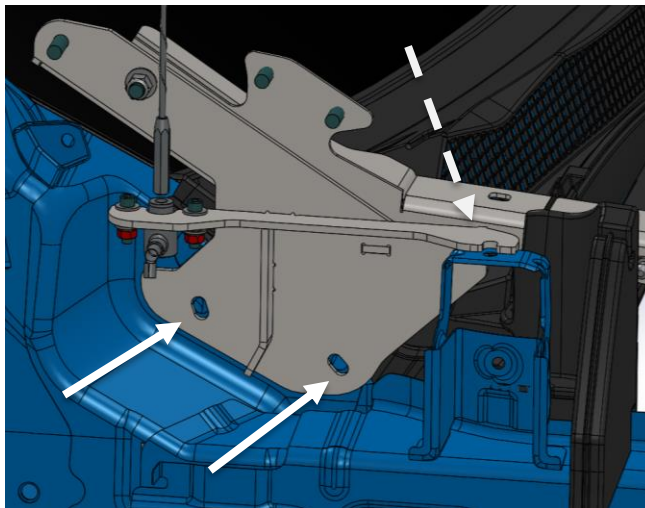

Figure 8

8. Using a ruler, set the height of the upper hole $\frac{1}{2}$ " above the closest portion of the fender profile. (**Figure 9**)



Installation Instructions

VICOWL

Product Number: VC4000

2019 Chevy 1500

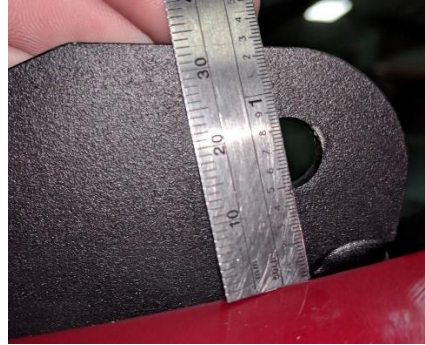

Figure 9

9. Fully tighten the lower two bolts, then the front fender bolt.
10. Using the ball joint, flat washer and M8 Nylock nut from the provided hardware kit, snap the OEM air spring to the ball stud on the upper bracket. (**Figure 6, Figure 10**)



Figure 10

11. The antenna is intended to be a snug fit between the fender and bracket. Once fully installed, it should look like **Figure 11**.



Figure 11

12. Repeat the same steps for the driver side bracket except the antenna installation.



Installation Instructions

VICOWL

Product Number: VC4000

2019 Chevy 1500

HOOD INSTALLMENT

1. With assistance, lift the hood onto the upper bracket of the hood brackets and hand tighten the four factory nuts.
2. Align the upper bracket with the missing paint marks made under the hood from the factory brackets.
3. Lower the hood slowly and check for uniform hood gap and alignment of lines on blue tape made during the disassembly of the OEM hinges at the beginning of this manual. Adjust as needed.
4. Slowly raise the hood just enough to reach in with a ratchet and fully tighten down the four factory bolts securing the hood.
5. Fully raise hood and reconnect the gas assist springs on the ball joint on the hinge upper arm.

Note: Be mindful of how high you raise the hood while making adjustments to alignment. It is possible that the hood will shift without your knowledge if hood is raised too high.

VICOWL PRE-ASSEMBLY

Note: It's highly recommended that all weld nuts are chased with the appropriate taps to clean out any powder coat or foreign debris prior to assembly. Tap sizes needed to do this are 1/2"-13 and 3/8"-16

1. Install and hand tighten the rubber bumpers and 1/2" flat washers to the visor.
(Figure 12)

Note: The rubber bonded washer is used on the outside surface of the visor to reduce any powder coat wear marks that would be created using flat washers and visible if bolts are moved due to reassembly of visor with light insert.



Installation Instructions

VICOWL

Product Number: VC4000

2019 Chevy 1500



Figure 12

2. Install and tighten the visor trim (or light insert if purchased) into the back of the visor using the nine (9) 5/16"-18 bolts, rubber bonded washer, flat washer, and 5/16"-18 Nylock nut provided in the hardware kit. (Figure 13)

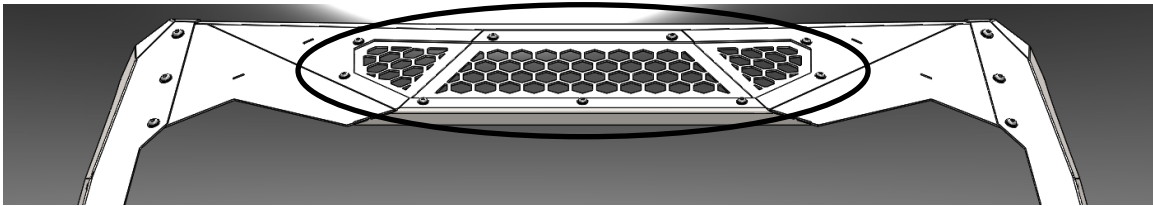

Figure 13

3. Install three (3) 1" neoprene rubber strips to the inside of both arms. (Figure 14)

Note: leave about a 1/8" reveal on the edge of the arms. This will ensure the rubber strip doesn't shift or show after installation.

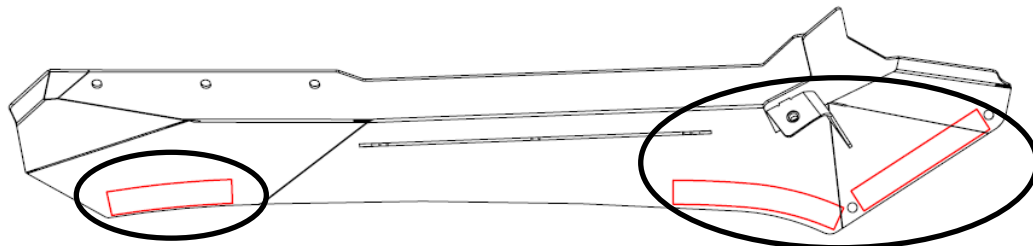

Figure 14

4. Loosely install both ViCowl arms to the visor using the six (6) 3/8"-16 bolts and rubber bonded washers provided in the hardware kit. (Figure 15)



Installation Instructions

VICOWL

Product Number: VC4000

2019 Chevy 1500

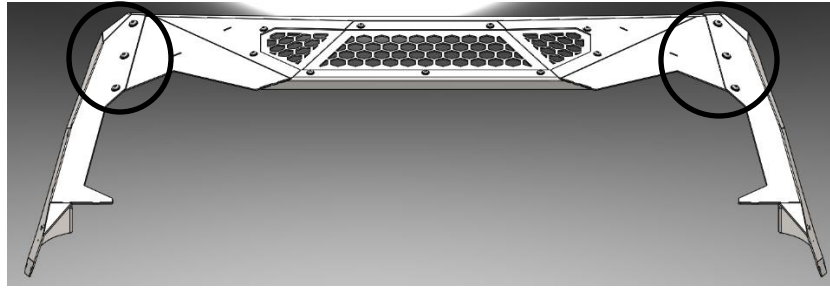

Figure 15

5. Install the edge trim with adhesive onto the leading edge of the Cowl. (Figure 16)

Note: Do not stretch the seal as you apply it to the Cowl. Doing so may cause the seal to pull away from the sheet metal in the future.

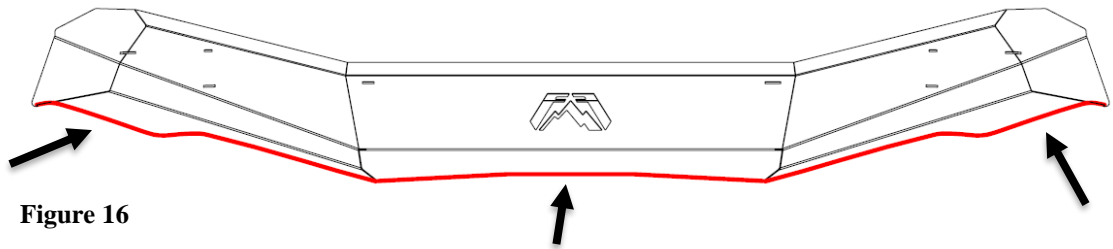

Figure 16

6. The edge seal should terminate at the hook of the Cowl on each end. (Figure 17)



Figure 17

7. Trim the edge seal for fit and finish.



Installation Instructions

VICOWL

Product Number: VC4000

2019 Chevy 1500

VICOWL INSTALLATION

1. With assistance, lift the upper ViCowl assembly up over the hood and slowly lower the arms into position. The arm mounting bracket should rest to the outside of the lower hinge and lined up with the rear bolt hole.
2. Loosely install the 3/8"-16 hex bolt, zinc lock washer and zinc flat washer through the lower hinge bracket and into the arm securing the ViCowl from falling lower on the vehicle. **(Figure 18)**

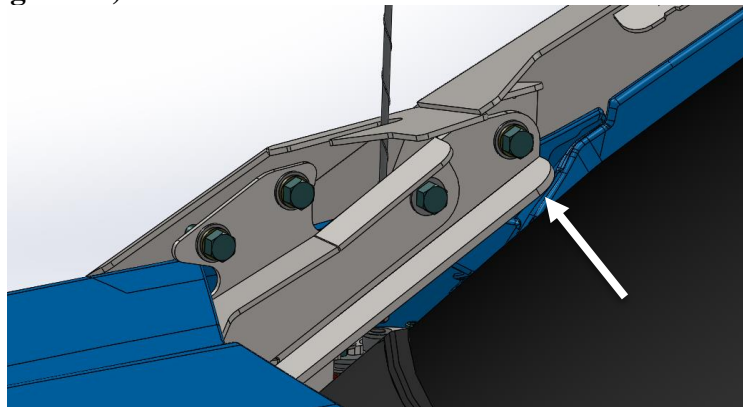

Figure 18

3. Check for fit and fully tighten down both arms to the hinge brackets.
4. Mark the Rivnut hole location on both driver and passenger fenders before removing the ViCowl for drilling. **(Figure 19)**

Note: A high degree of accuracy is needed when marking the Rivnut locations. The Rivnuts constitute a majority percentage of the mounting strength of the upper ViCowl to the vehicle. A hole center punch is recommended followed by incremental pilot holes to the finish hole size of the included 17/32" drill bit. You will have trouble lining up bolt holes if Rivnuts are misplaced.



Figure 19



Installation Instructions

VICOWL

Product Number: VC4000

2019 Chevy 1500

5. Remove the upper ViCowl assembly in preparation to drill and install the four Rivnuts in the fenders.
6. Use the 1/8" drill bit to drill pilot holes in each of the marked locations. Drill directly perpendicular to the side of the fender.
7. Drill out the holes with the 17/32" drill bit.
8. With the expendable tool threaded into the Rivnut, insert it into one of the holes making sure that it fits in far enough to flush the collar of the Rivnut to fender panel. For an exceptional installation coat the knurls of the Rivnut with Loctite.
9. Place the 9/16" box end wrench on the body of the expendable tool and the 9/16" socket and ratchet on the bolt head on the back side of the tool. **(Figure 20)**



Figure 20

10. Tighten the bolt into the Rivnut until it becomes snug in the fender panel. **DO NOT OVERTIGHTEN CAUSING THE INSERT TO SPIN!**
11. Repeat steps 6-10 to drill the remaining Rivnut hole locations marked on the vehicle.
12. With assistance, reinstall the upper ViCowl using steps 1-3 of the ViCowl installation section.
13. Install the 3/8"-16 button head bolts, rubber bonded washers using Loctite. **(Figure 21)**



Installation Instructions

VICOWL

Product Number: VC4000
2019 Chevy 1500



Figure 21

14. With assistance, lower the Cowl up on the mounting surface of the arms. The Cowl mounting surface goes to the outside of the bracket mounting surface.
15. Loosely install the four (4) 3/8"-16 bolts, flat washers and lock washers into the Cowl on both passenger and driver side. **(Figure 22)**

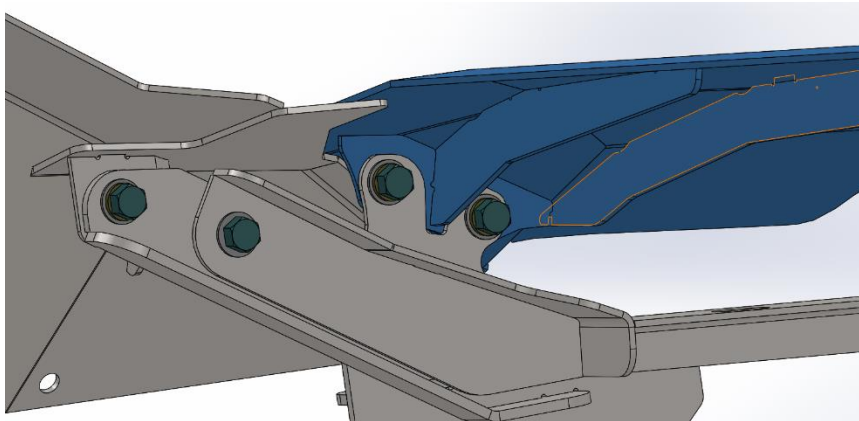

Figure 22

16. Using a plastic panel pry bar, insert the prybar under the Cowl and on top of the arm to maintain a symmetrical gap on each arm. **(Figure 23)**

Note: An 1/8" gap is required on both sides to prevent rubbing the Cowl and the arm together and causing damage.



Installation Instructions

VICOWL

Product Number: VC4000

2019 Chevy 1500



Figure 23

17. Push down the front of the Cowl closing any gap that may be between the hood and the edge trim of the Cowl. Fully tighten down the front bolt and then the back bolt.

Note: We recommend using an impact driver, long extension, and swivel to make tighten down of the Cowl hardware.

18. Remove the plastic panel pry bar.
19. Repeat steps 16-18 for the opposite side of the vehicle.
20. Once the ViCowl is fully installed, reinstall the well liners and splash guard.



Installation Instructions

VICOWL

Product Number: VC4000

2019 Chevy 1500

Maintenance/Care

- Periodically check and tighten all nuts.
- Stripped, fractured, or bent bolts or nuts need to be replaced.